



— BUREAU OF —
RECLAMATION

Design Standards No. 14

Appurtenant Structures for Dams (Spillways and Outlet Works)

**Chapter 4: General Outlet Works Design Considerations
Phase 4 Final**

Mission Statements

The U.S. Department of the Interior protects and manages the Nation's natural resources and cultural heritage; provides scientific and other information about those resources; and honors its trust responsibilities or special commitments to American Indians, Alaska Natives, and affiliated Island Communities.

The mission of the Bureau of Reclamation is to manage, develop, and protect water and related resources in an environmentally and economically sound manner in the interest of the American public.

Design Standards Signature Sheet

Design Standards No. 14

Appurtenant Structures for Dams (Spillways and Outlet Works)

**Chapter 4: General Outlet Works Design Considerations
Phase 4 Final**

Revision Number DS-14(4)-1

Summary of revisions:

- Revised bearing capacity safety factor equation in section 4.8.3.2 page 144

Prepared by:

ERNEST HALL Digitally signed by ERNEST HALL
Date: 2022.02.09 06:23:33 -07'00'

Ernest Hall, P.E.
Design Standard Team Leader

Date

Peer Review:



Digitally signed by ADAM
TOOTHMAN
Date: 2022.03.11 08:32:58 -07'00'

Adam Toothman, P.E.
Supervisory Civil Engineer, Waterways and Concrete
Dams 3

Date

Submitted:

ERNEST HALL Digitally signed by ERNEST HALL
Date: 2022.03.21 07:06:44 -06'00'

Ernest Hall, P.E.
Chief, Civil Engineering Services Division 2

Date

Approved:

RICHARD LAFOND Digitally signed by RICHARD
LAFOND
Date: 2022.06.29 09:54:41 -06'00'

Richard LaFond, P.E.
Director, Technical Service Center

Date

Foreword

Purpose

The Bureau of Reclamation (Reclamation) design standards present technical guidance, requirements and processes to enable design professionals to prepare design documents and reports necessary to manage, develop, and protect water and related resources in an environmentally and economically sound manner in the interest of the American public. Compliance with these design standards assists in the development and improvement of Reclamation facilities in a way that protects the public's health, safety, and welfare; recognizes needs of all stakeholders; and achieves lasting value and functionality necessary for Reclamation facilities. Responsible designers accomplish this goal through compliance with these design standards and all other applicable technical codes, as well as incorporation of the stakeholders' vision and values, that are then reflected in the constructed facilities.

Application of Design Standards

Reclamation design activities, whether performed by Reclamation or by a non-Reclamation entity, must be performed in accordance with established Reclamation design criteria and standards, and approved national design standards, if applicable. Exceptions to this requirement shall be in accordance with provisions of *Reclamation Manual Policy*, Performing Design and Construction Activities, FAC P03.

In addition to these design standards, designers shall integrate sound engineering judgment, applicable national codes and design standards, site-specific technical considerations, and project-specific considerations to ensure suitable designs are produced that protect the public's investment and safety. Designers shall use the most current edition of national codes and design standards consistent with Reclamation design standards. Reclamation design standards may include exceptions to requirements of national codes and design standards.

Deviations and Proposed Revisions

Reclamation designers should inform the Technical Service Center (TSC), via Reclamation's Design Standards Website notification procedure, of any recommended updates or changes to Reclamation design standards to meet current and/or improved design practices.

**Chapter Signature Sheet
Bureau of Reclamation
Technical Service Center**

Design Standards No. 14

Appurtenant Structures for Dams (Spillways and Outlet Works)

Chapter 4: General Outlet Works Design Considerations

**DS-14(4)-1:¹ Phase 4 Final
February 2022**

Design Standards No. 14 is a new document. Chapter 4 of this Design Standards was developed to provide:

- Technical processes for evaluating existing outlet works and selecting the type and size of outlet works modifications for existing dams.
- Technical processes for selecting the type, location, and size of a new outlet works for existing and/or new dams.
- A list of key technical references for evaluating existing outlet works and selecting the type, location, and size of a new outlet works for existing and/or new dams.

¹ DS-14(4)-1 refers to Design Standards No. 14, chapter 4, revision 1.

Prepared by:

John H. LaBoon

John LaBoon, P.E.
Design Standard Team Leader, Waterways and Concrete
Dams Group

3/27/2014

Date

Technical Approval:

Robert K. McGovern

Robert McGovern, P.E.
Civil Engineer, Waterways and Concrete Dams Group

3/27/14

Date

Security Review:

MIGUEL HERNANDEZ

Digitally signed by MIGUEL HERNANDEZ
Date: 2021.07.14 13:03:52 -06'00'

Miguel A. Hernandez
Civil Engineer, Waterways and Concrete Dams Group 1

Date

Peer Review:

Tomas E. Hepler, P.E.

Tom Hepler, P.E.
Technical Specialist, Waterways and Concrete Dams
Group

3/27/2014

Date

Submitted:

ERNEST HALL

Digitally signed by ERNEST HALL
Date: 2021.07.19 08:36:29 -06'00'

Ernest Hall, P.E.
Chief, Civil Engineering Services Division #2

Date

Approved:

RICHARD LAFOND

Digitally signed by RICHARD LAFOND
Date: 2021.07.19 10:07:25 -06'00'

Richard LaFond, P.E.
Director, Technical Service Center

Date

Acronyms and Abbreviations

ACER	Assistant Commissioner - Engineering and Research
ACI	American Concrete Institute
ASCE	American Society of Civil Engineers
ASR	alkali-silica reaction
CFD	computational fluid dynamics
CIPP	cured-in-place pipe
CJ	construction joint
CrJ	contraction joint
CtJ	control joint
DBE	design basis earthquake
DM	decision memorandum
DOC	Designers' Operating Criteria
EJ	expansion joint
EM	engineering manual or monograph
FEM	Finite Element Model
ft	feet
ft/d	feet per day
ft/lb	feet per pound
ft/s	feet per second
ft/s ²	feet per second squared
ft ²	square feet
ft ² /s	square feet per second
ft ³	cubic feet
ft ³ /s	cubic feet per second
ft ³ /s/ft	cubic feet per second per foot
HDPE	high density polyethylene
HP	high pressure (as in high pressure gate)
IDF	Inflow Design Flood
kN/m ²	kiloNewtons per square meter
kW/m ²	kilowatts per square meter
lb	pounds
lb/in ²	pounds per square inch
lb/in ² /in	pounds per square inch per inch
lb/ft ²	pounds per square foot

lb/ft ² /ft	pounds per square foot per foot
lb/ft ³	pounds per cubic foot
lb/lf	pounds per linear foot
m ²	square meters
m ³ /s	cubic meters per second
m ³ /s/m	cubic meters per second per meter
m/s ²	meters per second squared
M&I	municipal and industrial
M-O	Mononobe-Okabe
mPA	megaPascals
MSA	maximum sized aggregate
OCJ	optimal construction joint
O&M	operation and maintenance
OVIC	Ongoing Visual Inspection Checklist
PC	point of curvature
PFM	potential failure mode
PMF	Probable Maximum Flood
PT	point of tangency
PTI	Post Tensioning Institute
PVC	polyvinyl chloride
RCA	reservoir capacity allocation
RCC	roller compacted concrete
Reclamation	Bureau of Reclamation
ROV	remote operating vehicle
RWS	reservoir water surface
SOP	Standing Operating Procedures
SSD	saturated surface dry
sta.	station
TM	technical memorandum or technical manual
TSC	Technical Service Center
U	unformed concrete surface
USCOLD	United States Committee on Large Dams
USCS	Unified Soil Classification System

Contents

	<i>Page</i>
4.1	Scope 1
4.2	Definitions and Concepts..... 1
4.2.1	Outlet Works 2
4.2.1.1	River Outlet Works 2
4.2.1.2	Municipal and Industrial Outlet Works 4
4.2.1.3	Sluice Outlet Works 4
4.2.1.4	Power Outlet Works..... 7
4.2.1.5	Canal Headworks 7
4.2.2	Dams 7
4.2.2.1	Concrete Dams 13
4.2.2.2	Embankment Dams 13
4.2.2.3	Composite Dams 13
4.3	Function 13
4.3.1	General..... 14
4.3.2	Checklist and Procedure – Outlet Works Design 16
4.3.2.1	Checklist 16
4.3.2.2	Procedure 17
4.3.3	Sedimentation..... 21
4.3.3.1	Introduction 21
4.3.3.2	Design Considerations for Sediment at New and Existing Dams 22
4.3.4	Relationship Between Reservoir Storage Levels and Outlet Works Position 24
4.3.5	Outlet Works Configuration..... 25
4.4	Design Floods and Discharge Requirements..... 36
4.4.1	Inflow Design Flood and Other Design Floods 36
4.4.2	Construction Diversion Floods 36
4.4.3	Discharge Requirements..... 37
4.5	Outlet Works Location, Type, and Size 37
4.5.1	Outlet Works Location 37
4.5.1.1	Dam Abutments..... 37
4.5.1.2	Reservoir Rim..... 38
4.5.1.3	Beneath/Outside the Foundation-Dam Contact..... 39
4.5.1.4	Through a Dam..... 39
4.5.1.5	Outlet Works Foundations..... 40
4.5.2	Outlet Works Type and Size 40
4.5.2.1	Uncontrolled Outlet Works 43
4.5.2.2	Controlled Outlet Works..... 43
4.5.2.3	Considerations for Selecting Outlet Works Type and Size 59
4.5.2.4	Procedure for Selecting Outlet Works Type and Size..... 61
4.5.3	Examples 62

Contents (continued)

	<i>Page</i>
4.6	General Hydraulic Considerations 63
4.6.1	Discharge Capacity 63
4.6.1.1	Crest Control (Uncontrolled or Free Flow) 64
4.6.1.2	Orifice Control (Controlled Flow) 65
4.6.1.3	Pipe Control (Pressurized Flow) 67
4.6.1.4	Multiple Hydraulic Controls..... 67
4.6.1.5	Discharge Capacity Design Procedures..... 68
4.6.1.6	Existing Outlet Works..... 73
4.6.1.7	New Outlet Works..... 73
4.6.2	Flood Routing 74
4.6.2.1	Current Data 74
4.6.2.2	Starting RWS..... 75
4.6.2.3	Starting Time 75
4.6.2.4	Time Increments..... 76
4.6.2.5	Complete Routings..... 76
4.6.2.6	Robustness (Freeboard) Study..... 76
4.6.3	Reservoir Evacuation and First Filling..... 76
4.6.3.1	Current Data 77
4.6.3.2	Starting RWS..... 78
4.6.3.3	Hydrology 79
4.6.3.4	Reservoir Evacuation Risk and Hazard Classifications 81
4.6.3.5	Reservoir Evacuation Rates..... 83
4.6.3.6	Deviation from Reservoir Evacuation and First Filling Guidelines 84
4.6.4	Other Hydraulics..... 85
4.6.4.1	Intake Structures Hydraulics 86
4.6.4.2	Conveyance Features Hydraulics..... 88
4.6.4.3	Control Structures Hydraulics 99
4.6.4.4	Terminal Structures Hydraulics..... 100
4.6.4.5	Erosion Protection..... 104
4.7	General Foundation Considerations..... 108
4.7.1	Elastic Foundation 108
4.7.2	Foundation Design..... 111
4.7.2.1	Foundation Treatment..... 111
4.7.2.2	Foundation Acceptance..... 124
4.7.2.2.1	Foundation inspection and acceptance procedures..... 124
4.7.3	Drainage and Insulation..... 126
4.7.3.1	Drainage..... 126
4.7.3.2	Insulation 131

Contents (continued)

	<i>Page</i>
4.8	General Structural Considerations..... 131
4.8.1	Loading Conditions 132
4.8.2	Seismic (Earthquake) Loads 138
4.8.3	Stability Design..... 141
4.8.3.1	Loading Combinations..... 142
4.8.3.2	Stability Conditions..... 142
4.8.4	Reinforced Concrete Design 146
4.8.4.1	Strength Design 146
4.8.4.2	Loads..... 147
4.8.4.3	Load Combinations..... 147
4.8.4.4	Load Factors 148
4.8.4.5	Strength Reduction Factors (ϕ) 148
4.8.4.6	Serviceability Considerations for Hydraulic Structures 149
4.8.4.7	New Concrete and Reinforcement Properties 149
4.8.4.8	Existing Concrete and Reinforcement Properties 150
4.8.5	Reinforcement..... 151
4.8.6	Joints, Waterstops, and Tolerances..... 151
4.8.6.1	Joints 152
4.8.6.2	Waterstops 167
4.8.6.3	Tolerances..... 168
4.9	General Electrical/Mechanical Considerations..... 174
4.9.1	Mechanical Features 174
4.9.1.1	Gates and Valves..... 174
4.9.1.2	Air Venting for Gates and Valves..... 186
4.9.1.3	Bulkheads 186
4.9.1.4	Stoplogs 188
4.9.2	Operating Systems 188
4.10	Instrumentation and Monitoring..... 189
4.11	Technical References 190
4.12	References..... 192

Appendices

A	Examples: Outlet Works Location, Type, and Size
B	Typical Potential Failure Modes (PFMs) for Outlet Works
C	First Filling Guidelines

Tables

<i>Table</i>		<i>Page</i>
4.3.2.2-1	Procedure for outlet works design using quantitative risk analysis methodology.....	18
4.5.2.3-1	Considerations for selecting outlet works type and size.....	61
4.5.2.4-1	Procedure for selecting outlet works type and size.....	62
4.6.1.5-1	Procedure for estimating discharge capacity of an outlet works for crest control conditions.....	70
4.6.1.5-2	Procedure for estimating discharge capacity of an outlet works for orifice control conditions.....	71
4.6.1.5-3	Procedure for estimating discharge capacity of an outlet works for pipe control conditions.....	72
4.6.3.4-1	Reservoir evacuation risk considerations for significant and low hazard dams.....	82
4.6.3.5-1	Reservoir evacuation guidelines for storage and/or multipurpose dams, days.....	83
4.8.3.2-1	Minimum safety factors.....	145
4.8.6.1.6-1	Concrete joints associated with outlet works features.....	165
4.8.6.3-1	Surface tolerances (T_s).....	170
4.8.6.3.5-1	Procedure for selecting surface tolerances (TS).....	173
4.9.1.1-1	Gates and Valves Used in Outlet Works.....	176

Figures

<i>Figure</i>		<i>Page</i>
4.2.1.1-1	Examples of river outlet works.....	3
4.2.1.2-1	Examples of canal headworks and M&I outlet works.....	5
4.2.1.3-1	Examples of sluice outlet works.....	6
4.2.1.4-1	Examples of power outlet works.....	8
4.2.2-1	Example of RCA sheet.....	10
4.3.5-1	Outlet works configuration – common features.....	26
4.3.5-3	Arrangement 2 for embankment dams.....	29
4.3.5-4	Arrangement 3 for embankment dams.....	29
4.3.5-5	Arrangement 4 for embankment dams.....	30
4.3.5-6	Arrangement 2 for concrete dams.....	32
4.3.5-7	Arrangement 3 for concrete dams.....	32
4.3.5-8	Arrangement 4 for concrete dams.....	33
4.3.5-9	Arrangement 5 for concrete dams.....	33
4.4.3-1	Outlet works – example bypass system associated with an Arrangement 1 hydraulic control plan view of downstream control structure.....	38

Figures (continued)

<i>Figure</i>	<i>Page</i>
4.5.2-1	Outlet works type chart..... 41
4.5.2.2-1	Examples: tower intake structure 45
4.5.2.2-2	Examples: drop inlet intake structure..... 46
4.5.2.2-3	Examples: box intake structure 47
4.5.2.2-4	Examples: front-entrance intake structure 48
4.5.2.2-5	Examples: inclined intake structure 49
4.5.2.2-6	Examples: trashrack intake structure 50
4.5.2.2.3-1	Conveyance feature shapes (cross sections) most used for both conduits and tunnels..... 52
4.5.2.2.3-2	Examples: chutes associated with outlet works..... 58
4.5.2.2.5-1	Examples: terminal structures associated with outlet works 60
4.6.1.1-1	Crest control..... 65
4.6.1.2-1	Orifice control..... 66
4.6.1.3-1	Pipe control..... 68
4.6.1.5-1	Discharge curve - multiple hydraulic controls 69
4.6.4.1.2-1	Bellmouth flow surface..... 87
4.6.4.2.2-2	Cavitation damage occurred during operation of sluiceways at Folsom Dam, California 91
4.6.4.2.2-1	Cavitation simulation: (left) cavitation created in Reclamation’s low ambient pressure chamber: (right) cavitation damage noted after the test..... 91
4.6.4.2.4-1	Parabolic vertical curve illustration..... 96
4.6.4.2.4-2	Superelevation illustration 98
4.6.4.4-1	Terminal structures..... 101
4.6.4.4.3-1	Trajectory of a free jet illustration..... 104
4.6.4.5-1	Erosion potential – erodibility index versus stream power. 107
4.7.2.1.1-1	Cleaning and treatment of rock foundation 113
4.7.2.1.2-1	Slush grouting..... 114
4.7.2.1.2-2	Dental concrete 115
4.7.2.1.2-3	Beveled surfaces to eliminate feathered edges..... 116
4.7.2.1.3-2	Ring or pressure grouting 119
4.7.2.1.3-1	Backfill grouting..... 119
4.7.2.1.5-1	Anchor bars..... 122
4.7.2.1.5-2	Rock bolts 123
4.7.3.1-1	Drainage – zoned filter encasing downstream conduit section 128
4.7.3.1-2	Drainage – drainage holes in downstream tunnel 129
4.7.3.1-3	Air supply/demand 130
4.8.1-1	Concrete temperature history..... 133
4.8.6.1.1-1	CJ orientation (horizontal and vertical) 153
4.8.6.1.2-1	Transverse CrJs without foundation keys for flow surface slabs..... 155

Figures (continued)

<i>Figure</i>	<i>Page</i>
4.8.6.1.2-2	Transverse CrJs with foundation keys for flow surface slabs 156
4.8.6.1.2-3	Longitudinal CrJs for flow surface slabs and transverse CrJs for flow surface walls 157
4.8.6.1.3-1	Transverse CtJs without foundation keys for flow surface slabs ... 158
4.8.6.1.3-2	Transverse CtJs with foundation keys for flow surface slabs 159
4.8.6.1.3-3	Longitudinal CtJs for flow surface slabs and transverse CtJs and CJs for flow surface conduits and tunnels..... 160
4.8.6.1.4-1	Surface delamination near joints 162
4.8.6.1.5-1	EJs 164
4.8.6.2-1	Retrofit and strip waterstops 169
4.8.6.3-1	Surface roughnesses 170
4.8.6.3-2	Measuring surface roughnesses 171
4.9.1.1-1	Butterfly valve..... 178
4.9.1.1-2	Clamshell gate 178
4.9.1.1-3	Ensign valves..... 179
4.9.1.1-4	Fixed-cone valve or Howell-Bunger valve..... 179
4.9.1.1-5	Fixed-wheel gate or wheel-mounted gate..... 180
4.9.1.1-6	Gate valve 180
4.9.1.1-7	Hollow-jet valve 181
4.9.1.1-8	Jet-flow gate..... 181
4.9.1.1-9	Needle valve 181
4.9.1.1-10	Outlet gate..... 181
4.9.1.1-11	Paradox gate..... 182
4.9.1.1-12	Ring-follower gate..... 182
4.9.1.1-14	Ring-seal gate 183
4.9.1.1-13	Roller-mounted gate, similar to caterpillar, tractor, and coaster gates..... 183
4.9.1.1-15	Sleeve valve 184
4.9.1.1-16	Top-seal radial gate 184
4.9.1.1-17	Unbonneted slide gate..... 185
4.9.1.1-18	Bonneted slide gate 185
4.9.1.3-1	Bulkheads..... 187

Chapter 4

General Outlet Works Design Considerations

4.1 Scope

Design Standards No. 14 - Appurtenant Structures for Dams (Spillways and Outlet Works) provides technical guidance concerning the Bureau of Reclamation's (Reclamation) procedures and considerations for analyzing and designing two key types of appurtenant structures associated with storage and/or multipurpose dams and/or dikes. These appurtenant structures are spillways and outlet works. Chapter 4 provides technical processes for evaluating existing outlet works, along with selecting, locating, and sizing new outlet works. See Section 4.3.2, "Checklist and Procedure – Outlet Works Design," in this chapter, which summarizes these technical processes. These processes should be followed by Reclamation staff and others involved with analyzing and designing outlet works. These processes are used for all design activities such as appraisal, feasibility, and final design [1].¹ Specifically, this chapter provides general outlet works design considerations applicable to both existing and new dams. Unless otherwise noted, information provided in this chapter is applicable to the evaluation, analysis, and design of lined (primarily with reinforced concrete), high velocity, and high flow outlet works. Also, if the outlet works is used to help pass flood events, consideration should be given to the processes associated with the selection of the Inflow Design Flood (IDF)² that is addressed in Chapter 2, "Hydrologic Considerations," of this design standard. Finally, it should be stressed that this design standard will minimize duplication of other existing technical references and, wherever possible, it will reference existing procedures and considerations that should be used for the analysis and design of outlet works.

4.2 Definitions and Concepts

The following definitions and concepts are provided to clarify and explain the terminology used in this design standard. These definitions and concepts are consistent with other technical references used by Reclamation.

¹ Numbers in brackets [] indicate references listed at the end of this chapter.

² For most storage and/or multipurpose dams, selection of the IDF will be based on a quantitative risk analysis (for IDF selection process, see Chapter 2, "Hydrologic Considerations," of this design standard). The IDF will be less than or equal to the Probable Maximum Flood (PMF).

4.2.1 Outlet Works

An outlet works is a hydraulic structure that is primarily used to pass normal (operational) releases through a storage or multipurpose dam and, in some cases, is used to pass flood flows. An outlet works may also be an important feature of a construction diversion system (during modifications of existing facilities or new construction) and be the primary hydraulic structure used to evacuate the reservoir (see Section 4.6.3, “Reservoir Evacuation and First Filling,” in this chapter).

The term “outlet works” can be classified according to purpose, physical and structural arrangement, or hydraulic operation. The most common types of outlet works employed by Reclamation can be grouped into five classifications and are based on the primary use or purpose of the outlet works. These types are explained in more detail in the following sections.

4.2.1.1 River Outlet Works

A river outlet works is the most common type of outlet works in Reclamation’s inventory of outlet works for storage and multipurpose dams. The river outlet works serves to provide releases that can meet one or more purposes and requirements for the entire range of reservoir operations. A river outlet works will usually make releases back into the river or stream that is impounded by the dam. A river outlet works can be an appurtenant structure located through or adjacent to concrete and embankment dams or the concrete and embankment portion of a composite dam.

A river outlet works may be used for meeting normal releases (associated with irrigation, power generation, municipal and industrial needs, and environmental enhancement), augmenting flood discharge capacity, and evacuating the reservoir. Releases from a river outlet works are typically free-flow from the downstream end of the outlet works into a river or stream. Of note, the intake or sill elevation of a river outlet works will typically establish the top of dead storage capacity for a storage or multipurpose dam. The intake or sill elevation position must be sufficiently below the minimum reservoir operating level (such as top of inactive storage capacity) so that enough hydraulic head exists to provide required discharges. For more information about dead storage capacity, inactive storage capacity, and other reservoir capacity allocations details, see Section 4.2.2, “Dams,” in this chapter.

In addition to providing enough hydraulic head, the intake or sill elevation should be located above the projected (estimated) 100-year sediment level. Design and construction of a low-level sluice outlet works (see section 4.2.1.3) that could pass sediment to the downstream channel would help make the reservoir sustainable beyond the 100-year sediment design life. Examples of river outlet works are illustrated in figure 4.2.1.1-1.

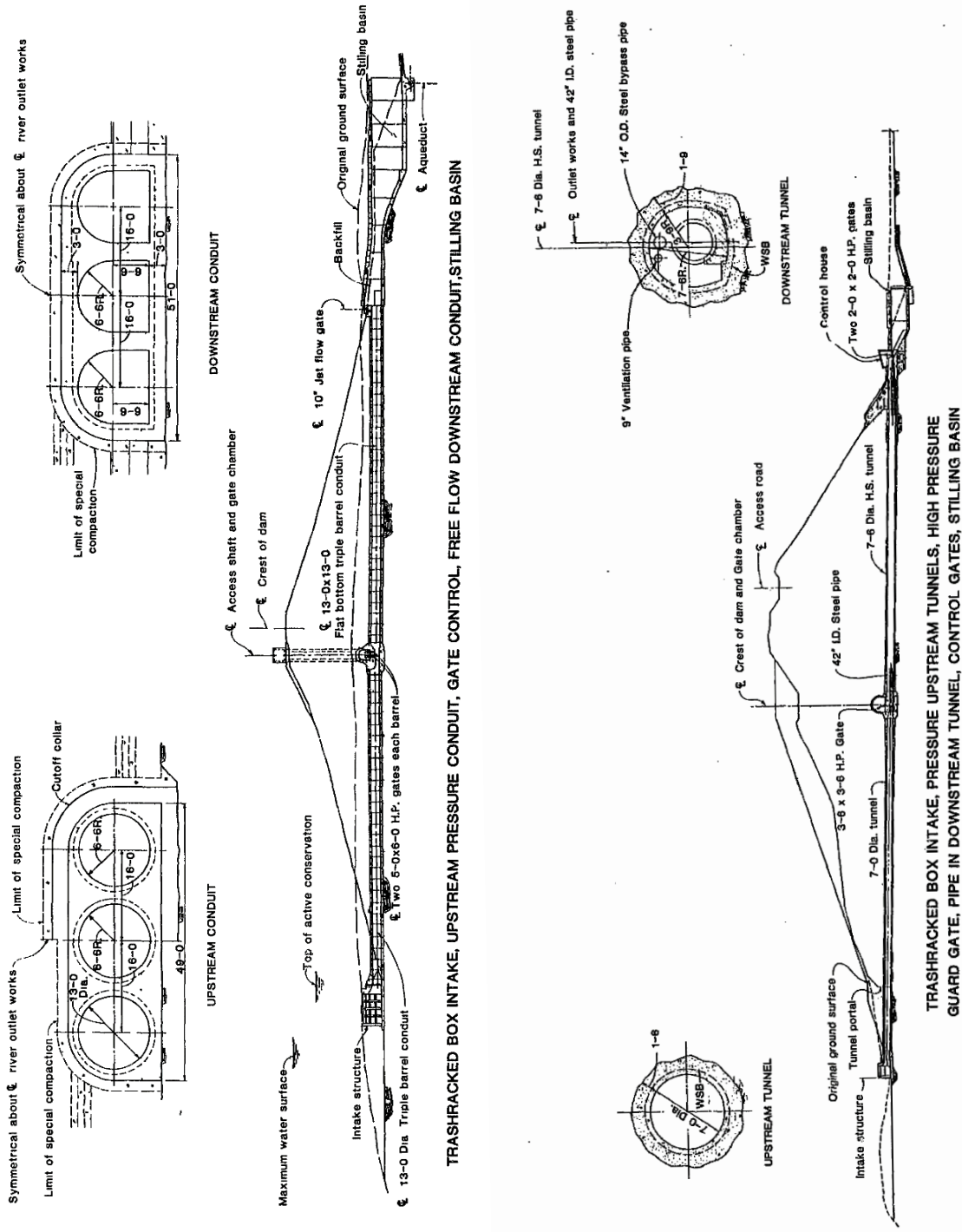

Figure 4.2.1.1-1. Examples of river outlet works.

Design Standards No. 14: Appurtenant Structures for Dams (Spillways and Outlet Works)

A common type of river outlet works is the low-level outlet works, which can be located as low as the riverbed. Along with meeting multiple purposes, the low-level outlet works maximizes the reservoir drawdown potential (i.e., evacuating the reservoir to the lowest reservoir water surface [RWS]).

Another type of river outlet works is the multiple level outlet works that will have multiple sills or intakes at different RWS elevations. This type of hydraulic structure provides flexibility for varying temperatures and water quality releases.

4.2.1.2 Municipal and Industrial Outlet Works

The primary purpose of a municipal and industrial (M&I) outlet works is to provide releases for domestic use, which could include water supply for residential and business uses. An M&I outlet works can be an appurtenant structure located through or adjacent to any type of dam. Releases from an M&I outlet works can be free-flow (such as into a canal) or pressure flow (such as into a pipeline). The intake or sill elevation of the M&I outlet works may be set at or above the top of dead storage capacity for a storage or multipurpose dam. The intake elevation will be influenced by reservoir operations and the discharge requirements associated with meeting domestic needs. Examples of M&I outlet works are illustrated in figure 4.2.1.2-1.

4.2.1.3 Sluice Outlet Works

Sluice outlet works or a sluiceway is typically associated with a concrete dam or the concrete portion of a composite dam; however, sluicing tunnels may be provided for an embankment dam. The primary purpose of the sluiceway is to flush sediment from reservoirs in order to reduce the loss in storage capacity over time. In concrete dams, sluiceways are also used to reduce the accumulation of sediment near the upstream face of the concrete dam. The sluice outlet works can include one or many conduits or pipes located in tiers or groups at the same or varying elevations. The sluiceway can be located in the spillway overflow monoliths (blocks) or in nonoverflow monoliths.

Releases from a sluiceway are typically free-flow into a river or stream. The intake or sill elevation of the lowest tier sluiceway will typically establish the top of dead storage capacity for a storage or multipurpose dam. Also, the intake or sill elevation location must be sufficiently below the minimum reservoir operating level (top of inactive storage capacity) so that enough hydraulic head exists to provide required discharges. For more information about dead storage capacity, inactive storage capacity, and other details on reservoir capacity allocations, see Section 4.2.2., “Dams,” in this chapter. Unlike most other outlet works, a sluiceway may be positioned at a low reservoir elevation to meet its primary purpose of flushing sediment from the reservoir. Examples of sluice outlet works are illustrated in figure 4.2.1.3-1. As with the river outlet works, the types of sluice outlet works can include low-level and multiple level outlets.

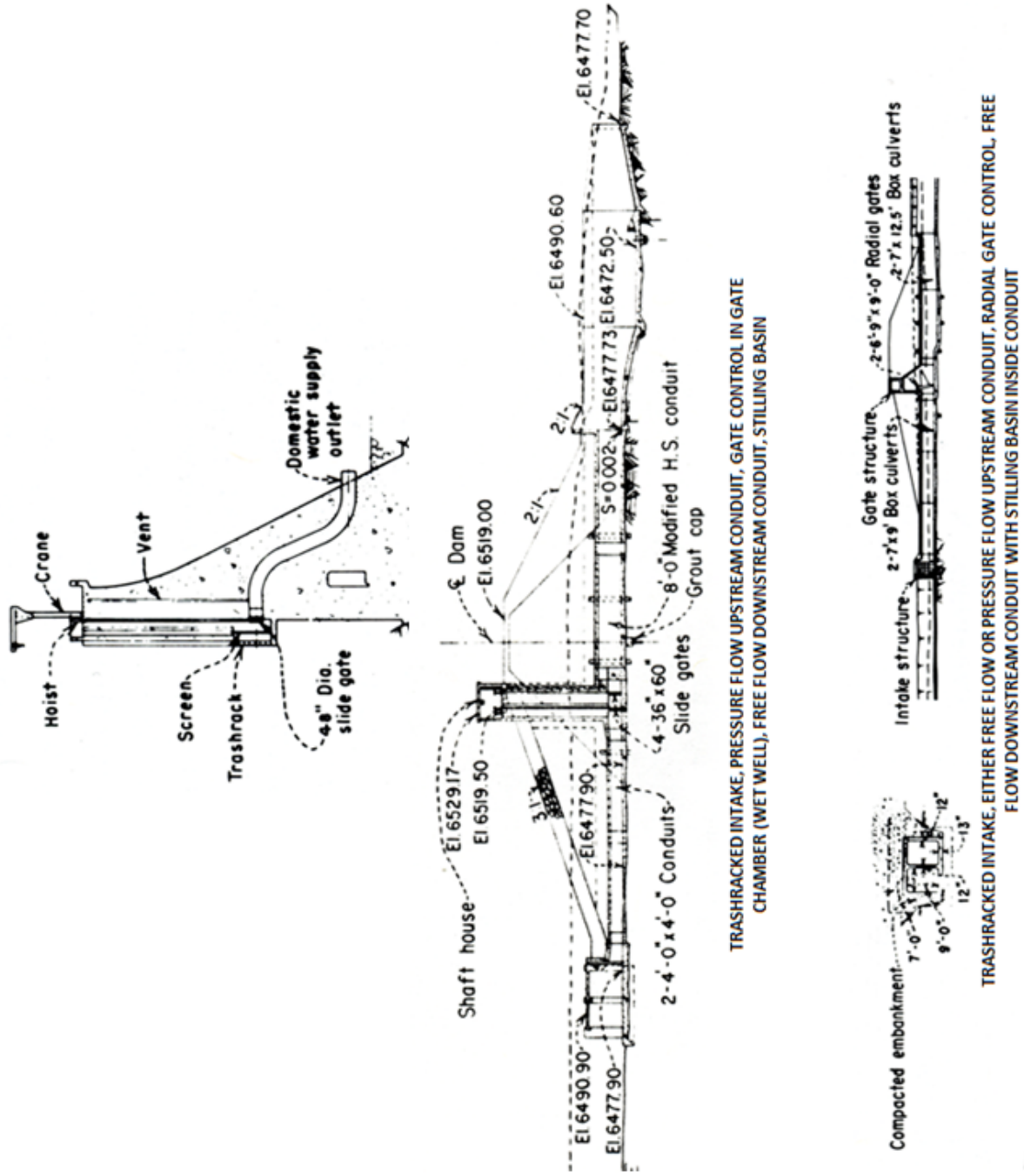

Figure 4.2.1.2-1. Examples of canal headworks and M&I outlet works.

Design Standards No. 14: Appurtenant Structures for Dams
(Spillways and Outlet Works)

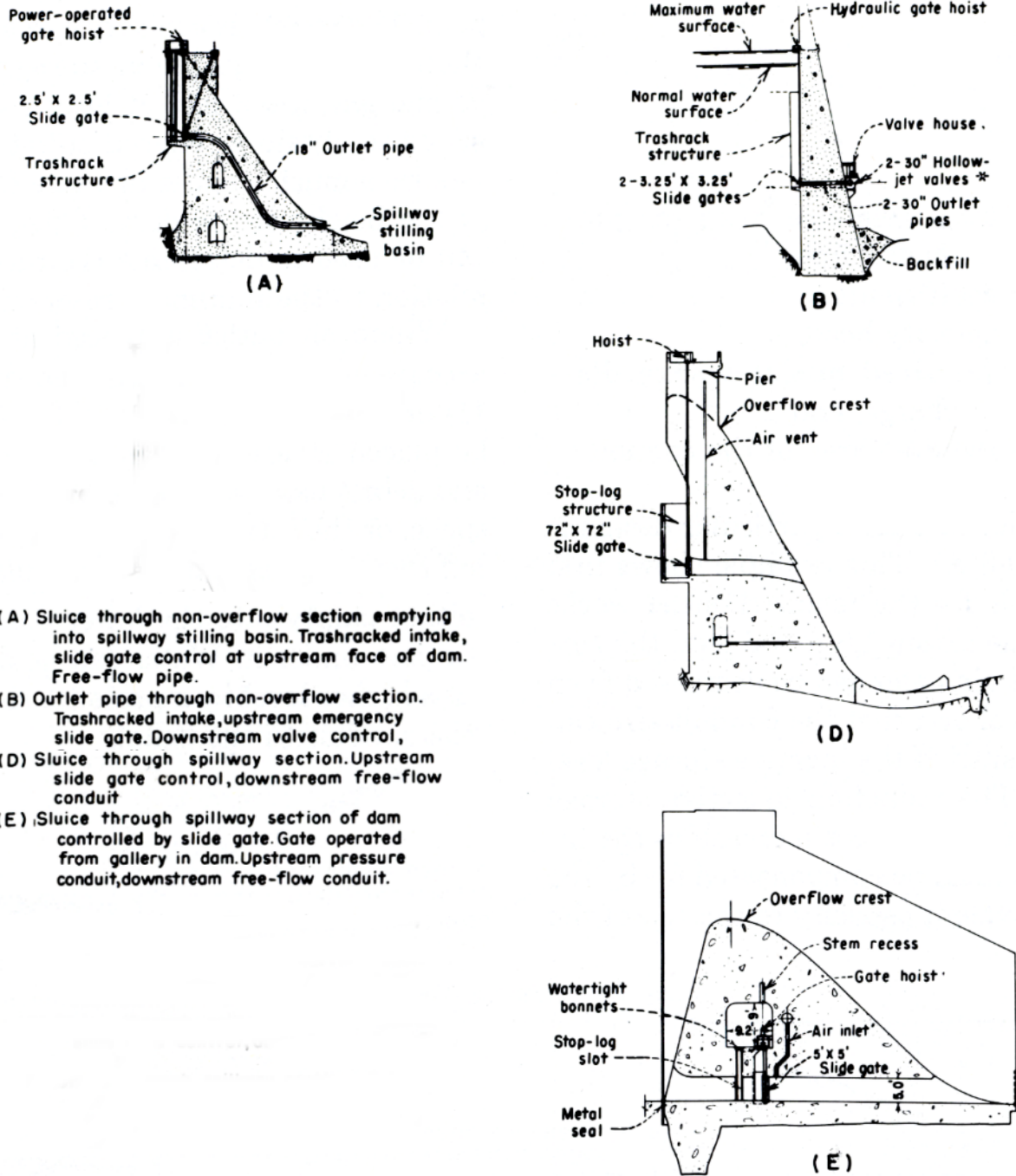

Figure 4.2.1.3-1. Examples of sluice outlet works.

4.2.1.4 Power Outlet Works

The primary purpose of a power outlet works is to convey water from the reservoir to a powerplant for the generation of electricity. A power outlet works can be an appurtenant structure located through or adjacent to any type of dam, as well as located a long distance from the dam through a reservoir rim. Releases from a power outlet works are pressure flow into the powerplant. The intake or sill elevation of a power outlet works is set to maximize and/or provide flexibility with power generation given the reservoir operations. Of note, minimizing hydraulic head loss is a key consideration associated with the power outlet works. Examples of power outlet works are illustrated in figure 4.2.1.4-1.

4.2.1.5 Canal Headworks

The primary purpose of a canal headworks is to divert (provide) releases for irrigation and, in some cases, furnish water for domestic purposes. Specifically, these purposes could include farming and ranching operations, along with water supply to communities (i.e., residential and business use). A canal headworks can be an appurtenant structure located through or adjacent to any type of dam. Releases from a canal headworks are typically free-flow conditions into a canal. The intake or sill elevation of a canal headworks is set at a relatively high reservoir elevation (low to moderate hydraulic head). Examples of canal headworks are illustrated in figure 4.2.1.2-1. For more details about canal headworks, refer to Chapter 3, “Diversion Dams and Headworks,” of *Design Standards No. 3 - Water Conveyance Facilities, Fish Facilities, and Roads and Bridges* [2].

4.2.2 Dams

The primary focus of this chapter involves outlet works associated with storage and multipurpose dams, rather than detention³ and diversion⁴ dams; however, there may be similar hydraulic structures associated with other types of dams. The purpose of storage and multipurpose dams is to impound water during periods of surplus supply for use during periods of deficient supply. The uses of the stored water at Reclamation facilities include: irrigation, M&I, recreation, fish and wildlife, hydroelectric power generation, and other purposes. When power operation comes into play, the multipurpose dam may serve as a forebay dam⁵ (such as Reclamation’s Banks Lake impounded by North and Dry Falls

³ Detention dams are constructed to temporarily store streamflow or surface runoff and then release the stored water in a controlled manner.

⁴ Diversion dams are constructed to divert (redirect) water from one waterway (such as a stream or river) into another waterway (such as a canal or pipeline).

⁵ Forebay dams impound water from another dam or hydroelectric plant intake structure (typically a pump-storage facility). A forebay dam can also be designed as a storage, run-of-the-river, and/or pump-storage dam.

**Design Standards No. 14: Appurtenant Structures for Dams
(Spillways and Outlet Works)**

(a) Mass concrete of the dam encased the 13.5-foot-diameter penstocks, which were installed as the concrete was placed.

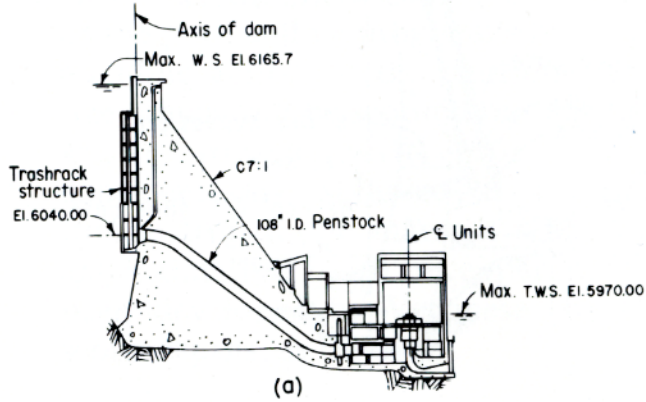

(b) The 15-foot-diameter penstocks were embedded in the concrete of the dam at the upstream ends and were exposed above ground between dam and power plant.

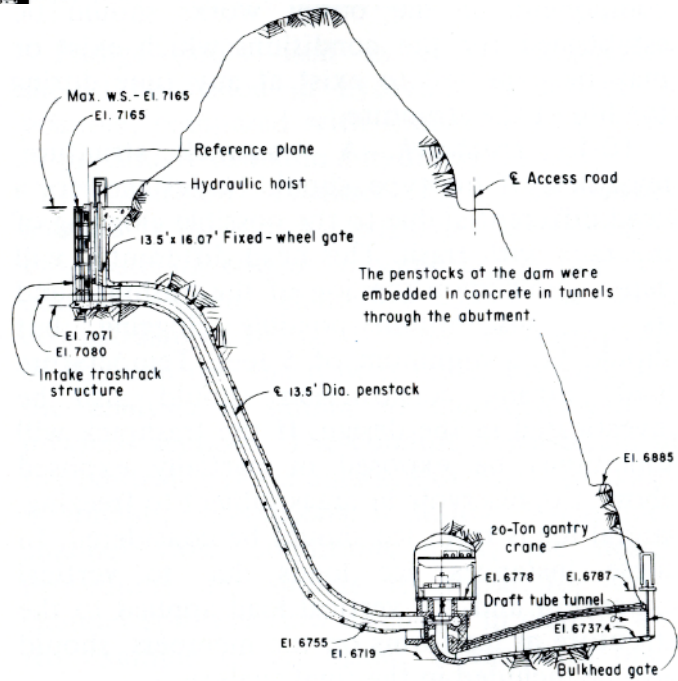
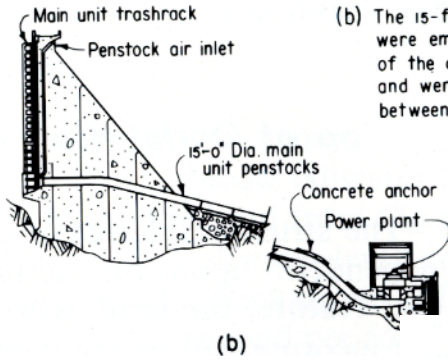

Figure 4.2.1.4-1. Examples of power outlet works.

Dams) or an afterbay dam⁶ (such as Reclamation's Yellowtail Afterbay Dam). The uses of the stored water are based on the official (authorized) reservoir capacity allocation (RCA) purposes. Use of the RCA is further discussed in Section 4.3.3, "Relationship Between Reservoir Storage Levels and Outlet Works Position," in this chapter. An example RTA sheet is shown in figure 4.2.2-1.

Storage definitions associated with the RCA for a given storage and multipurpose dam follow:

- **Freeboard.** The vertical distance between a stated reservoir water level and the crest of a dam, without camber in the case of an embankment dam.
- **Surcharge capacity.** The reservoir capacity provided for use in passing the IDF through the reservoir. It is the temporary storage between the maximum RWS elevation and the highest of the following elevations: top of exclusive flood control capacity, top of joint use capacity, or top of active conservation capacity.
- **Exclusive flood control.** The reservoir capacity assigned for the sole purpose of regulating flood inflows to reduce flood damage downstream. In some instances, the top of exclusive flood control capacity is above the maximum controllable RWS elevation (either top of active conservation capacity or top of joint use capacity). A few examples of Reclamation dams with exclusive flood control include Ririe, Hoover, Brantley, and Jordanelle Dams.
- **Flood control pool (flood pool).** The reservoir capacity above active conservation capacity and joint use capacity that is reserved for flood runoff and then evacuated as soon as possible to keep the reservoir volume in readiness for the next flood. Controlled releases generally take place when the RWS is within the flood control pool.
- **Joint use capacity.** The reservoir capacity assigned to flood control purposes during certain periods of the year (normally when flooding is more likely to be a concern) and to conservation purposes during other periods of the year.

⁶ Afterbay dams are located downstream from other dams and/or hydroelectric plants and are used to regulate tailwater adjacent to the upstream dams and/or hydroelectric plants.

Design Standards No. 14: Appurtenant Structures for Dams (Spillways and Outlet Works)

7-1686 (5-06)
Bureau of Reclamation

RESERVOIR CAPACITY ALLOCATIONS

TYPE OF DAM	Embankment - Zoned Earthfill		REGION	MP	STATE	California
OPERATED BY	Bureau of Reclamation		Lake Example		RESERVOIR	
CREST LENGTH	3,350 FT.	CREST WIDTH	40 FT.	Example Dam		DAM
VOLUME OF DAM	6,895 CU YD.		Example Project		PROJECT	
CONSTRUCTION PERIOD	2000-2003		---		DIVISION	
STREAM	Example River		---		UNIT	
RES AREA	3,090 ACRES AT EL 750	Operational		STATUS OF DAM		
ORIGINATED BY:	J.H.L. 86-68130 12/15/2004		APPROVED BY:			
	(Initials)	(Code)	(Date)	R.K.M.	86-68130	12/15/2004
				(Initials)	(Code)	(Date)

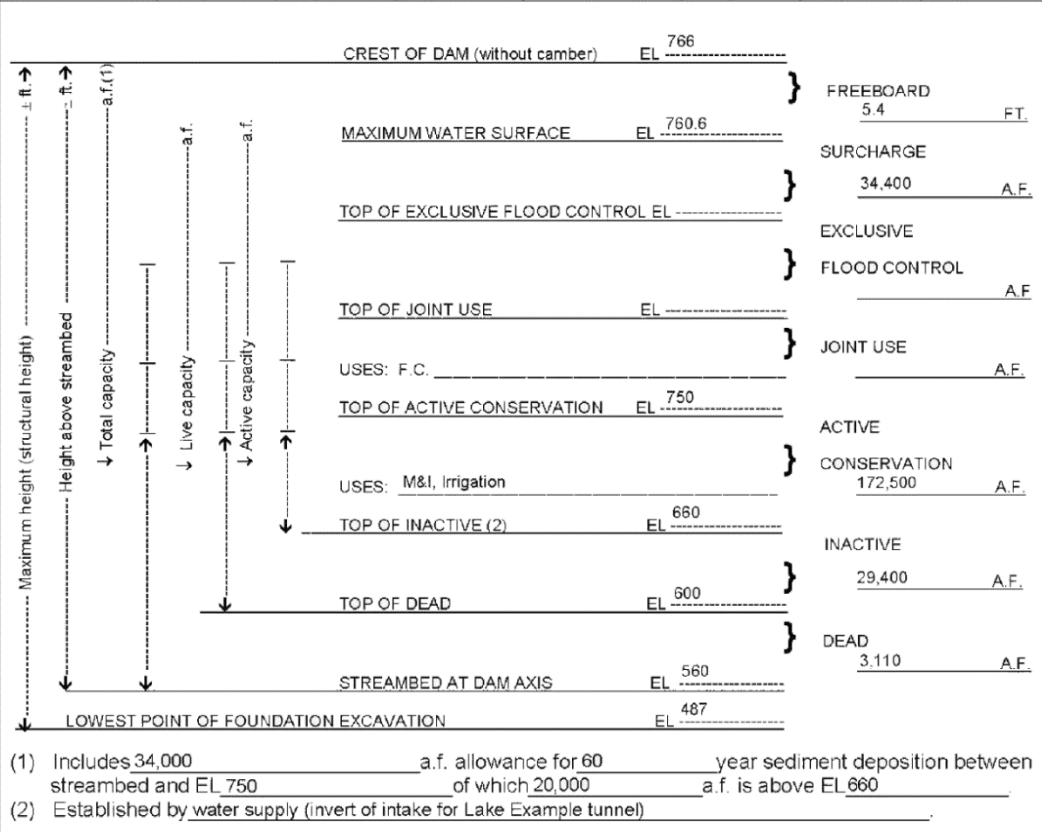

REFERENCES AND COMMENTS:

Specifications DC-99999, Supplemental notices, and as-built drawings.

Technical Record of Design and Construction, July 2004.

Area-Capacity Table, No. 999-D-9999, 3 sheets.

Inactive storage will be used to satisfy downstream water rights and, by pumping, project water supply requirements during extremely dry periods when active conservation storage is exhausted.

Figure 4.2.2-1. Example of RCA sheet.

Chapter 4: General Outlet Works Design Considerations

- **Active conservation capacity (active storage).** The reservoir capacity assigned to regulate reservoir inflow for irrigation, power generation, M&I use, fish and wildlife, navigation, recreation, water quality, and other purposes. It does not include exclusive flood control or joint use capacity. It extends from the lowest RWS associated with the bottom of exclusive flood control, or the bottom of flood control pool, or the bottom of joint use capacity to the top of the inactive capacity (or to the top of dead capacity where there is no inactive capacity).
- **Inactive capacity (inactive storage).** The reservoir capacity exclusive of and above the dead capacity from which the stored water is normally not available because of operating agreements or physical restrictions (such as minimum hydraulic head needed to meet certain release requirements associated with power generation, irrigation, M&I, recreation, and environmental enhancements). Under abnormal conditions, such as a shortage of water or a requirement for structural repairs, water may be evacuated from this space. The inactive capacity extends from the top of inactive capacity to the top of dead capacity.
- **Dead capacity (dead storage).** The reservoir capacity from which stored water cannot be evacuated by gravity (using existing appurtenant structures).
- **Live capacity.** Reservoir storage that includes exclusive flood control capacity plus joint use capacity plus active capacity plus inactive capacity.
- **Total capacity.** Reservoir storage that includes the live capacity plus dead capacity.

Elevation definitions associated with the RCA and reservoir operations for a given storage and multipurpose dam follow:

- **Crest of dam.** The elevation of the uppermost surface of a dam, usually a road or walkway, excluding any parapet wall, railing, curb, etc. On embankment dams, the crest of the dam is the top of the embankment, not including camber, crown, or roadway surface. Camber is the extra height added to the crest of embankment dams to ensure that the freeboard will not be diminished by foundation settlement or embankment consolidation.
- **Maximum water surface.** The maximum or highest RWS reached during the passing of a flood event up to the PMF. The maximum RWS reached during the passing of the IDF represents the maximum reservoir elevation used to size the dam and associated appurtenant structures such as spillways and outlet works.

**Design Standards No. 14: Appurtenant Structures for Dams
(Spillways and Outlet Works)**

- **Top of exclusive flood control.** The RWS elevation at the top of the reservoir capacity allocated to exclusive use for the regulation of flood inflows.
- **Top of joint use.** The RWS elevation at the top of the reservoir capacity allocated to joint use (i.e., flood control and conservation purposes).
- **Top of active conservation.** The RWS elevation at the top of the capacity allocated to the storage of water for conservation purposes only. If there is no joint use capacity associated with the reservoir, the top of active conservation is the RWS elevation above which no reservoir storage will occur under normal operating conditions.
- **Top of inactive.** The RWS elevation below which the reservoir will not be evacuated under normal conditions.
- **Top of dead.** The lowest elevation in the reservoir from which water can be drawn by gravity.
- **Streambed at dam axis.** The lowest point of elevation in the streambed at the axis or centerline of the dam prior to construction. This elevation defines the hydraulic height and normally defines zero storage or surface area for the area-capacity tables.
- **Lowest point of foundation excavation.** The lowest point of elevation below the streambed that is reached during excavation of the dam foundation (excluding treated narrow/small fault zones).
- **Hydraulic height.** The vertical distance between the lowest point in the streambed at the axis or the centerline of the dam—or the invert of the lowest outlet works, whichever is lower—and the maximum controllable RWS.
- **Structural height.** Generally defined as the vertical distance between the lowest point in the excavated foundation and the crest of the dam.
 - For embankment dams, the structural height is the vertical distance between the dam crest and the lowest point in the excavated foundation area, including the main cutoff trench, if any, but excluding small trenches or narrow backfilled areas. The crest elevation does not include the camber, crown, or roadway surfacing.
 - For concrete dams, the structural height is the vertical distance between the top of the dam and the lowest point of the excavated foundation area, excluding narrow fault zones.

There are three general types of storage and multipurpose dams: (1) concrete dams, (2) embankment dams, and (3) composite dams. These storage and multipurpose dam types are further discussed in the following sections.

4.2.2.1 Concrete Dams

Less than 10 percent of Reclamation's inventory of storage or multipurpose dams are concrete dams. Some of the better known Reclamation concrete dams include Hoover, Grand Coulee, Shasta, and Buffalo Bill Dams. General types of concrete dams include arch, buttress, multiple-arch, and gravity structures. Typical construction materials include conventional mass concrete, reinforced concrete, roller compacted concrete (RCC), and masonry. With few exceptions, a competent rock foundation is required for a suitable concrete dam site. For additional information and details about concrete dams, refer to *Design Standards No. 2 - Concrete Dams* [3].

4.2.2.2 Embankment Dams

The vast majority of Reclamation's inventory of storage or multipurpose dams are embankment dams. Some of the better known Reclamation embankment dams include Blue Mesa, Jordanelle, and Horseshoe Dams. General types of embankment dams include earthfill and rockfill dams. Construction materials are typically soil and rock from local excavation sources. Other materials may include concrete, soil cement, and RCC, which may be used as facing elements and/or impervious barriers. Due to a large footprint and lower stresses in the dam foundation, the foundation and topographical requirements for embankment dams are less stringent than those for concrete dams (with appropriate engineering, an embankment dam can be placed on either a soil or rock foundation). For additional information and details about embankment dams, refer to *Design Standards No. 13 - Embankment Dams* [4].

4.2.2.3 Composite Dams

Reclamation's inventory of storage or multipurpose dams includes a few composite dams, which are a combination of concrete and embankment dams. Some of the better known Reclamation composite dams include Folsom, Pueblo, and Minidoka Dams. Construction materials include those associated with both concrete and embankment dams. Competent rock foundations would still be expected for the concrete portion of a composite dam, while less stringent foundations (soil and/or rock) may be acceptable for the embankment portion of a composite dam.

4.3 Function

An outlet works regulates or releases water impounded by a dam. It can release incoming flows at a limited rate through an uncontrolled pipe, conduit, tunnel, and/or culvert (as is associated with a detention dam); it can divert incoming flows into canals or pipelines (as is associated with a diversion dam); or it can release stored water at rates dictated by downstream needs, by reservoir

Design Standards No. 14: Appurtenant Structures for Dams (Spillways and Outlet Works)

evacuation considerations, or by a combination of multipurpose requirements such as irrigation, M&I, and environmental enhancement (as is associated with a storage or multipurpose dam) [5].

4.3.1 General

With few and very unusual exceptions, an outlet works is the one hydraulic structure that must be included for a storage and/or multipurpose dam. The importance of a safe, reliable outlet works cannot be overemphasized. Many issues have been caused by improperly designed, constructed, and/or operated outlet works or by outlet works of insufficient discharge capacity.

The discharge (such as the discharge capacity to draw down the reservoir in a timely fashion to mitigate an emergency) is determined by the purposes or uses of the outlet works. Common uses that should be considered in establishing the discharge capacity of an outlet works may include one or more of the following:

- **Irrigation releases.** The discharge capacity is based on the critical period of low runoff when the reservoir storage is low and daily irrigation demands are at their peak. This lower-bound release requirement can play a role in establishing sufficient hydraulic head at the hydraulic control point, which could be at the intake structure or some downstream location such as a gate chamber and/or control house needed to meet the discharge requirement. This hydraulic head is the depth of an allocated reservoir storage space, which is referred to as the inactive storage capacity.
- **Evacuation releases.** The discharge capacity is based on lowering an allocated control space such as exclusive flood control and joint use storage during a specified timeframe. Also, the discharge can be based on lowering the active storage space for inspection, maintenance, repair, or emergency drawdown within a specified timeframe. Upper-bound releases should generally not exceed the downstream safe channel capacity. The lower-bound releases should be at least equal to the average inflow expected during the evacuation time period. For more information, see Section 4.6.3, “Reservoir Evacuation and First Filling,” in this chapter.
- **First filling.** The discharge capacity is based on controlling the RWS rate of rise during the initial reservoir filling of a new dam or the RWS rate of rise above historical maximums of an existing dam. Anytime the RWS exceeds the historical maximum level experienced by a dam, first filling guidelines should apply. For more information, see Section 4.6.3, “Reservoir Evacuation and First Filling,” of this chapter and Appendix C, “First Filling Guidelines.”

Chapter 4: General Outlet Works Design Considerations

- **Flood releases.** The discharge capacity may be used to release surplus flood inflows, augmenting the discharge capacities of other hydraulic structures (such as spillways) or providing the primary ability to pass floods. For more information about selecting the IDF or other design floods and routing them, see Chapter 2, “Hydrologic Considerations,” of this design standard. The lower-bound releases should be at least equal to the average inflow expected during the flood time period.
- **Sedimentation.** Due to increasing water demands, aging infrastructure, and a limited number of feasible and economical sites for new dam construction [6], Reclamation must limit the loss of reservoir capacity due to factors such as sedimentation. One way of making dams and reservoirs more sustainable is designing outlet works with the ability to pass sediment downstream. For more information, see Section 4.3.3, “Sedimentation,” of this chapter.
- **Power releases.** The discharge capacity required to generate electrical power. To meet power requirements, the discharge may vary with time of the day and/or season. The discharge capacity would be associated with a reservoir storage space that would typically be bounded by the top of inactive storage and either the top of active conservation or top of joint use storage.
- **Diversion releases (during construction).** The discharge capacity associated with passing flows through or around a construction site. The maximum release capacity is typically based on selecting and/or identifying a construction diversion flood (frequency flood) and designing the diversion system (which could include the outlet works) to safely accommodate the construction diversion flood. For more information about identifying and/or selecting a construction diversion flood, see Chapter 2, “Hydrologic Considerations” of this design standard.
- **Other releases.** The discharge capacity associated with specific requirements such as environmental enhancement (preservation of aquatic life, abatement of stream pollution, etc.) and M&I needs. Unless these other release requirements are the primary purpose of the outlet works, the discharge capacity will likely be controlled by other factors (see previous bullets) because required releases tend to be fairly small. However, these other releases could determine the minimum release capability of the outlet works, which could result in including a smaller bypass system.

See Section 4.4, “Design Floods and Discharge Requirements,” of this chapter for more details.

Design Standards No. 14: Appurtenant Structures for Dams (Spillways and Outlet Works)

In addition to providing sufficient discharge capacity, the outlet works must be located so that releases do not erode or undermine the downstream toe of the dam. The outlet works' flow surfaces must be erosion resistant to withstand the high scouring velocities created by the elevation drop from the RWS to the tailwater (downstream) level. A feature typically referred to as a terminal structure is often required to dissipate the kinetic energy of the moving water at or below the tailwater level.

An important consideration associated with embankment dams is to isolate the outlet works from the embankment dam (such as a tunnel outlet works through the dam abutment, rather than through the embankment dam). In some cases, constructing a tunnel outlet works may not be possible. In these cases, robust design and construction efforts should be employed such as placing the outlet works in a foundation notch (below or outside of the dam-foundation contact), then encasing the reinforced concrete outlet works in conventional mass concrete or reinforced concrete. The additional concrete used to fill the notch would conform to the embankment-foundation contact and isolate the outlet works from the embankment dam. Also, steel lining and/or embedded steel pipe (encased in the reinforced concrete outlet works) can further add to a robust design. For more details about lining, see Section 4.5.2.2.3, "Conveyance Features," of this chapter.

4.3.2 Checklist and Procedure – Outlet Works Design

This section is the primary focus of chapter 4 and summarizes how Reclamation analyzes and designs both new outlet works and modifications of existing outlet works. The "Checklist – Outlet Works Design Considerations" (Checklist) itemizes technical activities, and Table 4.3.2.2-1, "Procedures for Outlet Works Design Using Quantitative Risk Analysis," provides the design steps.

4.3.2.1 Checklist

The Checklist outlines Reclamation's approach to identifying and evaluating outlet works type, location, and size, along with refining analyses and designs of an outlet works. The remainder of this chapter augments this Checklist.

Note: The Checklist provides listings of major technical activities but does not provide the overarching project management process used by Reclamation. For additional guidance about Reclamation's project management processes, refer to the *Final Design Process Guidelines* [7] and the *Safety of Dams, Project Management Guidelines* [8].

Additional clarification of the following Checklist includes:

- **Data.** A Data Table summarizes considerations that are necessary to prepare analyses and designs for modifying existing outlet works and constructing new outlet works. This list covers all levels of analyses and design, ranging from appraisals and feasibilities to final designs. It is important to note that activities associated with the Data Table parallel and/or are interactive with activities associated with Location Table and the Type and Size Table.
- **Location.** A Location Table summarizes considerations that are necessary to properly locate a new outlet works (for an existing outlet works, the location of the modification is already defined). As with the Data Table, this table covers all levels of analyses and design, ranging from appraisals and feasibilities to final designs. It is important to note that activities associated with the Location Table parallel and/or are interactive with activities associated with the Data Table and the Type and Size Table.
- **Type and size.** A Type and Size Table summarizes considerations that are necessary to properly select the type and size of a new outlet works or modification to an existing outlet works. As with the Data and Location Tables, this table covers all levels of analyses and design, ranging from appraisals and feasibilities to final designs. It is important to note that activities associated with the Type and Size Table parallel and/or are interactive with activities associated with the Data Table and the Location Table.
- **Analysis and design.** An Analysis and Design Table summarizes considerations needed to refine and/or finalize the modification to an existing outlet works or the analysis and design of a new outlet works. This table covers all levels of analyses and design, ranging from appraisals and feasibilities to final designs.

It is important to note that the Data Table, Location Table, and Type and Size Table are parallel to and interact with one another.

4.3.2.2 Procedure

Quantitative risk analysis methodology will be part of evaluating, analyzing, and/or designing modifications to existing outlet works or designing new outlet works.

The procedure for applying quantitative risk analysis methodology is summarized in table 4.3.2.2-1.

**Design Standards No. 14: Appurtenant Structures for Dams
(Spillways and Outlet Works)**

Table 4.3.2.2-1. Procedure for Outlet Works Design Using Quantitative Risk Analysis Methodology

<p>Step 1 (Locate, Lay Out, and Size)</p>	<p>Based on topography, geology, and hydrology— along with loading conditions and load combinations— locate, lay out, and size the modified or new outlet works. For examples of locating, typing, and sizing an outlet works, see Appendix A, “Examples: Outlet Works Locations, Type, and Size,” of this chapter. For flood and seismic loadings, initial assumptions are made in terms of the return periods to be used for the maximum and minimum discharge capacity, along with design earthquake (see Table 4.5.2.4-1, “Procedures for Selecting Outlet Works Type and Size,” of this chapter). For more details about selecting the maximum and minimum discharge capacity and design earthquake, see Section 4.4, “Design Discharges,” and Section 4.8.2, “Seismic (Earthquake) Loads,” of this chapter.</p>
<p>Step 2 (Perform Risk Analysis)</p>	<p>When modifying an existing outlet works, prepare or update baseline risk analysis and prepare modified risk analysis. When designing a new outlet works, prepare baseline risk analysis. Note: Risk analyses should be comprehensive where total risks are estimated (i.e., evaluates all credible potential failure modes [PFMs] associated with static, hydrologic, and seismic loadings). For a list of typical PFMs associated with outlet works, see Appendix B, “Potential Failure Modes (PFMs) for Outlet Works,” of this chapter. For more details about identifying and evaluating PFMs and preparing or updating risk analyses, refer to <i>Best Practices in Dam and Levee Safety Risk Analysis</i> [9].¹</p>
<p>Step 3 (Evaluate Risk Analysis Results)</p>	<p>Evaluate risk analysis results in terms of:</p> <ul style="list-style-type: none"> • Are total modified risks (for existing outlet works) or baseline risks (for new outlet works) acceptable? (If YES, go to last bullet – if NO, go to next bullet.) • What PFMs significantly contribute to the total risks? (As an example, risks associated with an earthquake-induced separation between the outlet works conduit and surrounding embankment, leading to internal erosion failure of the dam, might be very large; therefore, a more remote earthquake than initially assumed as the design load could reduce this PFM risk and also total risks). • Are construction risks (associated with modifying an existing outlet works or constructing a new outlet works) acceptable? (If YES, go to Step 5 – if NO, go to Step 4.)
<p>Step 4 (Revise Loading Conditions)</p>	<p>Identify revised loading conditions (such as more remote flood and/or earthquake design load return periods) and changes to the outlet works design that would result in reduced risks for PFMs that significantly contribute to the total risks, along with limiting construction risks. Repeat Steps 1 through 3.</p>
<p>Step 5 (Identify Minimum Loading Conditions)</p>	<p>Identify minimum static, hydrologic, and seismic loadings that would reduce total risks to acceptable levels (results from Step 3 or Step 4). It should be highlighted that for a new outlet works or new features of an existing outlet works, all appropriate structural criteria, guidelines, codes, and safety factors must be met as a minimum. Designs using quantitative risk analysis may dictate that these minimum structural and stability requirements be exceeded but never decreased. Note: Presently, hydrologic load uncertainties are addressed in a Robustness (freeboard) study (see Chapter 2, “Hydrologic Considerations,” of this design standard). Processes to evaluate static and seismic load uncertainties are not well defined, but they would generally follow a similar approach noted for the hydrologic load uncertainties.</p>
<p>Step 6 (Evaluate Nonrisk Factors)</p>	<p>Evaluate nonrisk factors (i.e., water delivery requirements, cost, physical constraints) that need to be considered in addition to the risk factors.</p>
<p>Step 7 (Refine)</p>	<p>Based on the previous steps, refine modifications to existing outlet works or design of new outlet works.</p>

¹ For the remainder of this document, reference [9] will be referred to as *Best Practices*.

CHECKLIST – Outlet Works Design Considerations

Data Table	Location Table	Type and Size Table	Analysis and Design Table
<ol style="list-style-type: none"> 1. Reservoir and site topography (develop topography for identified potential outlet works locations): Refer to <i>Design Data Collection Guidelines</i> [10].* 2. Reservoir and site geology (develop geologic data including subsurface and material data for identified potential outlet works locations): Refer to <i>Design Data Collection Guidelines</i> [10].* 3. Seismicity (earthquakes), which includes earthquake return periods that could range from a Design Basis Earthquake (DBE) for noncritical structures to risk-based earthquake loadings for critical structures that could be in the range of 10,000- to 50,000-year return periods: See section 4.8 of this chapter. 4. Hydrology (floods), which includes flood and nonflood season frequency events to determine the discharge capacity and identify/select construction diversion floods: See section 4.4 of this chapter. 5. Reservoir operations would be defined in the Standing Operating Procedures (SOP) for existing Reclamation dams. Also, release requirement agreements with other agencies or owners may need to be addressed. For other non-Reclamation existing dams or for new dams, reservoir operations should be well defined by Owner/Client: Refer to <i>Design Data Collection Guidelines</i> [10].* 6. Reservoir storage is defined in the SOP for existing Reclamation dams. For other non-Reclamation existing dams or for new dams, reservoir storage should be well defined by the Owner/Client. If not available, reservoir storage will be developed from reservoir topography. Also, RCA should be defined and include some or all of the following: dead storage capacity, inactive capacity, active conservation capacity, joint use capacity, and exclusive flood control. Additionally, sedimentation loading potential should be evaluated and defined: See section 4.2.2 and 4.3.3 of this chapter, and refer to <i>Design Data Collection Guidelines</i> [10].* <p>* NOTE: Dam design data collection requirements are used because there are no design data requirements specifically identified for outlet works.</p>	<ol style="list-style-type: none"> 1. When possible, avoid locating outlet works near or through embankment dams (embankment material may settle, causing unfavorable foundation conditions, as well as increase potential for internal erosion). The exceptions should be based on no other viable, cost-effective alternatives: See sections 4.3.3 and 4.5 of this chapter. 2. Locate outlet works near or through dam abutment or reservoir rim for embankment dams: See sections 4.3.3 and 4.5 of this chapter. 3. Outlet works integral with concrete dams may provide the best location. If not, consider dam abutment or reservoir rim: See section 4.5 of this chapter. 4. Location may be influenced by the possibility of the outlet works being used for diversion during construction. An example would be a tunnel outlet works that is used to direct riverflows around the dam construction site. Also, location could be influenced by the sedimentation loading potential. 5. Preferred foundation is rock, if available. Some soils may provide suitable foundation (gravel to gravelly soils, sands to sandy soils, and some fine-grained soils with low to medium compressibility, but permeability as related to internal erosion potential must be carefully evaluated): See sections 4.5 and 4.7 of this chapter. 6. For soil foundations that are removed and replaced with engineered fill or for soil foundation disturbed before placement of concrete, minimum compactive levels would include 94% compaction (cohesionless soils) using the vibratory hammer test or 95% Proctor density (cohesive soils). It may be necessary to either design the outlet works to accommodate settlement or treat the foundation to minimize the settlement: Refer to section 4.7 of this chapter. 	<ol style="list-style-type: none"> 1. Identify outlet works type: river, M&I, sluiceway, power, or canal: See sections 4.2, 4.3, and 4.4 in this chapter. 2. Identify potential combinations of intake structure, conveyance features, control structure, and terminal structure types. Considerations will include: dam type; outlet works type; discharge capacity; foundation conditions; loading conditions; and reservoir operational requirements and diversion: See section 4.5 of this chapter. 3. Initial sizing (including elevations and dimensions) of outlet works via discharge capacity estimates: See section 4.6 of this chapter. 4. Evaluate and select hydrologic and seismic design loadings in risk framework: See sections 4.4 and 4.8 of this chapter. 5. Refine viable outlet works via refining discharge capacity and flood routings (if applicable). Also, refine design for foundation, structural, mechanical, and electrical considerations: See sections 4.6, 4.7, 4.8, and 4.9 of this chapter. 6. Identify initial control features location and type including emergency or guard gate/valve, regulating gate/valve, and stoplogs or bulkhead. Note: consider minimum release requirements that may require additional smaller gates/valves (bypass consideration). Base this on initial hydraulic, foundation, structural, mechanical, and electrical analyses: See sections 4.6, 4.7, 4.8, and 4.9 of this chapter. 7. Estimate initial baseline risks for viable alternative outlet works (adjust as needed): See appendix B of this chapter and refer to <i>Best Practices</i> [9]. 8. Lay out and prepare cost estimates of viable alternative outlet works (combinations of intake structure, conveyance features, control structures, and terminal structure) which have acceptable initial baseline risks: See appendix B of this chapter. 9. Refer to <i>Best Practices</i> [9] and <i>Estimate Worksheet – Guide for Designers</i> [11]. 10. Develop viable construction diversion scheme, based on construction schedule, resulting in acceptable construction risks: See chapter 2 of this design standard and refer to <i>Best Practices</i> [9]. 11. Select recommended viable alternative outlet works. 	<ol style="list-style-type: none"> 1. Finalize hydraulic analyses and designs for recommended viable alternative outlet works: See section 4.6 and appendix A in this chapter. <ul style="list-style-type: none"> • Discharge Capacity (section 4.6.1). • Flood Routing (section 4.6.2). • Reservoir Evacuation and first filling (section 4.6.3). • Other Hydraulics (section 4.6.4). 2. Finalize foundation analyses and designs for recommended viable alternative outlet works: See section 4.7 and appendix A in this chapter. <ul style="list-style-type: none"> • Elastic Foundation (section 4.7.1). • Foundation Design (section 4.7.2). • Drainage and Insulation (section 4.7.3). 3. Finalize structural analyses and designs for recommended viable outlet works alternative(s): See section 4.8 in this chapter. <ul style="list-style-type: none"> • Loading Conditions (section 4.8.1). • Seismic (Earthquake) Loading (section 4.8.2). • Stability Design (section 4.8.3) • Reinforced Concrete Design (section 4.8.4). • Reinforcement (section 4.8.5). • Joints, Waterstops, and Tolerances (section 4.8.6) 4. Finalize mechanical and electrical designs for recommended viable outlet works alternative(s): See section 4.9 in this chapter. <ul style="list-style-type: none"> • Mechanical Features (section 4.9.1). • Operating Systems (section 4.9.2). 5. Determine need for instrumentation and monitoring: See section 4.10 in this chapter. 6. Verify that baseline risks indicate “decreasing justification to take action to reduce risks” for the recommended viable outlet works alternative(s): See appendix B in this chapter and <i>Best Practices</i> [9]. 7. Prepare technical documentation, such as design summary, supporting technical memoranda and reports, decision memoranda, designers’ operating criteria, and final construction report: See Safety of Dams Project Management Guidelines [8].

Parallel with and/or interactive between data, location, and type/size

Parallel with and/or interactive between data, location and type/size

This page intentionally left blank.

4.3.3 Sedimentation

Design considerations for accommodating sediment loading should not be overlooked; therefore, the following guidance should be carefully considered. In addition to this guidance, consult with the Sedimentation and River Hydraulics Group in Reclamation's Technical Service Center (TSC).

4.3.3.1 Introduction

Without reservoir sediment management, a reservoir storing water will continue to fill with sediment over time, causing storage loss and infrastructure impacts, particularly to outlet works and powerplant intakes. The rate of reservoir sedimentation varies across the world and is very site specific, ranging from an average annual storage loss of 2.3 percent in China to 0.2 percent in parts of North America [12]. Sedimentation rates in the United States may be as high as an average annual storage loss rate of 2.0 percent per year. The traditional approach in the design of dams in Reclamation is to size a dead pool to account for 100 years of sediment accumulation and locate the outlet works intake elevation at the top of the dead pool. However, reservoir sediment accumulation affects all levels of the reservoir [13], affecting all storage allocations by use (e.g., conservation, multi-use, or flood pool). Many Reclamation facilities are already nearing or are past their original design life of 100 years. These reservoirs still serve critical water storage needs, and these needs will likely continue for the indefinite future. These aging reservoir facilities likely have no plan for sediment management or other reservoir site available to replace the lost storage capacity, so periodic retrofitting and upkeep are necessary for continued use.

As previously noted in Section 4.3.1, "General," of this chapter, current and new Reclamation facilities need to be designed and/or retrofitted for sustainable use in terms of limiting the loss of reservoir capacity due to sedimentation. One way of making dams and reservoirs more sustainable is designing outlet works with the ability to pass sediment downstream.

There are several cases of Reclamation facilities that already pass measurable amounts of sediment downstream. Such facilities include Paonia Dam in Colorado, Guernsey Dam in Wyoming, and Black Canyon Dam in Idaho.

In the case of Paonia Dam, the outlet works was designed with a dead pool to allow reservoir sedimentation, where the outlet works intake elevation is 68 feet above the outlet exit elevation. Since dam closure in 1962, sediment has deposited throughout the reservoir, reducing the reservoir capacity by 25 percent, with the dead pool nearly full of sediment. Operators at the dam have observed plugging of the outlet works under traditional operations. Beginning in

Design Standards No. 14: Appurtenant Structures for Dams (Spillways and Outlet Works)

2010-2011, the operations of the dam had to be changed to manage the incoming sediment, now at the level of the outlet works intake. Paonia Reservoir has a Storage Capacity to Mean Annual Inflow (C:I) ratio of 0.16, which means the reservoir can only store 1/6 of the mean annual runoff. Under new operations, the reservoir is drawn down at the end of the irrigation season to flush deposited sediments, pass incoming sediments, and reduce the amount of storage loss (maintain storage capacity). Previous studies have investigated the potential of constructing a lower outlet works intake to pass sediment and increase storage capacity to meet irrigation demands downstream [14]. Additional studies have included analyzing the timing of operations and potential outlet works modifications to sluice more sediment through the outlet works to maintain or improve reservoir capacity.

There are a variety of techniques to remove sediment from a reservoir, and sediment pass-through can also occur with a full reservoir, in the form of venting turbid density currents [12]. Turbid density currents are a denser plume of sediment relative to clear reservoir water. Turbid density currents follow the bottom topography of the reservoir and have the potential to travel over long distances, arriving at the base of the dam. Turbid density currents traveling 80 miles were documented in Lake Mead shortly after the closure of Hoover Dam [15]. Outlet works located at the base of the dam can vent turbid density currents, passing significant amount of sediment, and thereby reducing the amount of storage loss. If outlet works modification is not feasible, a curtain upstream of the dam face can be constructed to vent turbid density currents upward to higher outlet works and/or spillway structures [16].

4.3.3.2 Design Considerations for Sediment at New and Existing Dams

The design should meet clearly defined objectives for reservoir sediment management. These objectives could include:

- Maintenance and/or recovery of reservoir storage
- Maintenance of open reservoir pool for recreation use
- Decrease in the sediment concentration entering the penstock intake

Based on a defined set of objectives, several sources of literature (Basson and Rooseboom, 1997 [16]; Morris and Fan, 1998 [17]; Utah Division of Water Resources, 2010 [13]) provide considerations to aid in the design of outlet works to pass sediment. A compilation of these general considerations are listed below:

- The design life of the reservoir sediment management plan should be consistent with the expected operational service life of the entire project.
- The location of the sluice outlet works is the most important consideration:

Chapter 4: General Outlet Works Design Considerations

- In general, the sluice outlet works should be located at a low elevation in the reservoir.
- The existence of a dead pool will hamper flushing effectiveness until the dead pool fills.
- Produce retrogressive erosion in the reservoir (maintain or improve reservoir capacity).
- Consider the ability to vent turbidity currents with a full pool.
- The placement of both sluices and service intakes should be planned so that the service intakes will be maintained free of sediment by sluice operation.
- If site conditions make it impossible to place the sluice outlet works below the service intakes, it may be feasible to divert the flushing flow into the vicinity of the service intakes by constructing a low dike partway across the channel upstream of the dam, thereby directing the flushing channel along the desired alignment.
- If possible, place the intake structure near the old riverbed on the outside bend.
- Design the sluice outlet works for a sufficient size to pass high sediment flows. Discharge capacity should ideally be designed for the 5- to 10-year flood inflow capacity.
- In general, the sluice outlet works should be as wide as possible.
- Two side-by-side sluices are preferred, rather than two sluices at different levels, because the former arrangement will produce lower backwater at a given discharge.
- Design of upstream gates (near or on the intake structure) should include consideration of the future elevation of sediment on the gates (e.g., clogging, extra lift forces).
- For the passing of coarse sediments (sands and gravels), the sluice outlet works flow surfaces need to be abrasion resistant (e.g., high strength concrete), and consideration should be given to joints along the flow surfaces, which are the weakest points. Coatings on the outlet work flow surfaces may slow the abrasive effects of the sediment.

Design Standards No. 14: Appurtenant Structures for Dams (Spillways and Outlet Works)

- Operation of the reservoir may require partial or full drawdown to flush or sluice sediments to maintain capacity.

These design considerations are a preliminary list to follow in the design of sluice outlet works with the consideration to future sedimentation and sustainability.

4.3.4 Relationship Between Reservoir Storage Levels and Outlet Works Position

The primary factor in locating the outlet works position is attaining the required discharge. The outlet works must be located sufficiently below the minimum reservoir operating level to provide the hydraulic head needed for the required discharge. As previously discussed in Section 4.2.2, “Dams,” of this chapter, Reclamation uses the official (authorized) RCA to achieve specific purposes associated with a given storage or multipurpose dam. The RCA will establish key storage and elevation requirements, which, in turn, will influence the position of the outlet works (for definitions of RCA terms and an example of a RCA sheet, see Section 4.2.2, “Dams,” and figure 4.2.2-1 in this chapter, respectively). The relationship between reservoir storage, as defined by the RCA and outlet works position, is further highlighted by the following bullets:

- **Inactive storage capacity.** It is common practice to make allowances for the inactive storage capacity to accommodate sediment deposition, fish and wildlife conservation, and recreation, along with sufficient hydraulic head (above the outlet works intake) to meet minimum discharge requirements. With this in mind, the outlet works position must be high enough to avoid sediment deposits (typically above the estimated 100-year sediment level), but at the same time, low enough to permit either a partial or a complete drawdown below the top of the inactive storage, which may be needed for maintenance, inspection, and/or addressing emergency evacuation, along with meeting first filling requirements. Design and construction of a low-level sluice outlet works (see sections 4.2.1.3 and 4.3.3.2 of this chapter) that could pass sediment to the downstream channel would help make the reservoir sustainable beyond the 100-year sediment design life.
- **Conveyance feature size.** The size (or cross-sectional area) of the conveyance feature (conduits and/or tunnels) for a required discharge is inversely proportional to the square root of the available hydraulic head for producing the discharge. This relationship is expressed by the following equations (assuming pressure or pipe flow conditions):

$$H = K_1 h_v \dots \text{or} \dots H = K_2 \frac{Q^2}{A^2} \text{ (forms of Bernoulli's equation)}$$

Where: Q is the total discharge (ft³/s)
 h_v is the velocity head where $h_v = V^2/2g = Q^2/2ga^2$ (ft)
 H is the total hydraulic head needed to produce Q (ft)
 K_1, K_2 are the coefficients determined from the hydraulic head losses (h_L) and velocity head (h_v) associated with a given Q , or $K_1 = (h_v + h_L)/h_v$ and $K_2 = K_1/2g$
 A is the required (wetted) area of the conveyance feature (ft²)

The above relationship can be used to develop an economic study which determines the initial size of the outlet works conveyance features for a given total hydraulic head (H). The total hydraulic head is based on the allocated reservoir storage associated with the inactive and active capacities. For further details, refer to *Design of Small Dams* [5]. For more details about the hydraulics of an outlet works, see Section 4.6, “General Hydraulic Considerations,” of this chapter.

- **Diversion (during construction).** If an outlet works will be part of the diversion system and/or be used to drain the reservoir, it will typically be positioned at or near riverbed level. For this situation, an operating sill may be located at a higher level or be designed to be raised in the future. In other words, an intake structure may have a sill elevation set at the top of dead pool level, as well as a separate temporary diversion intake set at a lower elevation that is used during construction, then plugged at the end of construction. This approach typically uses a drop inlet or tower intake structure and will provide an allocated dead storage or inactive storage between the operating sill and riverbed. This storage space would accommodate sediment and debris accumulation over time.

4.3.5 Outlet Works Configuration

There are some common or typical configurations (features) associated with an outlet works. Generally speaking, features common to most outlet works are illustrated in figure 4.3.5-1 and include:

- **Approach, inlet, or entrance (upstream) channel.** This channel conveys water from the reservoir to the intake structure. Although not common, there are some applications of safety/debris/log booms for outlet works that are located high in the reservoir and may be subject to concentrations of wind/wave driven debris and human encroachment via boats.

**Design Standards No. 14: Appurtenant Structures for Dams
(Spillways and Outlet Works)**

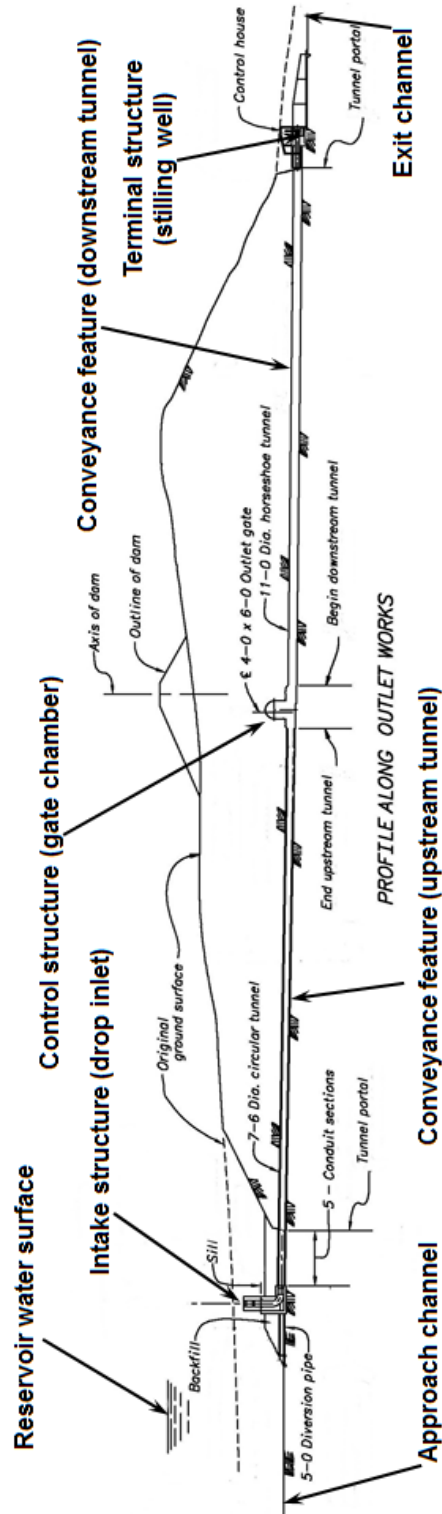

Figure 4.3.5-1. Outlet works configuration – common features.

Chapter 4: General Outlet Works Design Considerations

- **Intake structure** could be a box inlet or intake tower and might also include trashracks, gates/valves, and bulkheads (if appropriate). This structure conveys water from the reservoir to the conveyance feature.
- **Conveyance feature** could be a conduit, tunnel, or chute. These features convey water from the intake structure to the control structure and/or terminal structure. The conveyance feature may include multiple elements such as combinations of conduits, tunnels, and chutes, etc. The conveyance feature configuration will be influenced by many factors including geology, topography, and operational requirements.
- **Control structure** could be a gate chamber, access shaft/adit/conduit, and/or control house, which contains the gates/valves along with operating equipment. In some cases, the control structure may be combined with the intake structure.
- **Terminal structure** could be a hydraulic jump stilling basin, flip bucket, stilling well, or impact basin. This structure either dissipates most of the kinetic energy associated with moving water and conveys the water from the conveyance feature to the exit channel, or it conveys high energy flow downstream where the kinetic energy is dissipated within the natural river or stream channel.
- **Exit, outlet, or discharge (downstream) channel** conveys water from the terminal structure to the river or stream.

Other considerations that will influence the outlet works configuration include:

- **Dual gates/valves.** Reclamation’s practice is to use at least two gates or valves in series (one guard or emergency⁸ gate/valve and one regulating gate/valve for each outlet) that can be operated under unbalanced hydraulic head conditions. For more details about gates and valves, see Section 4.9, “General Electrical/Mechanical Considerations,” of this chapter.
- **Hydraulic control arrangements.** As part of the design for outlet works, gate/valve arrangements should be defined.

⁸ The terms “guard” and “emergency” gate/valve are considered interchangeable. In some cases where there are more than two gates/valves in series, the furthest upstream gate/valve is designated as “emergency,” while the gate/valve immediately upstream of the regulating gate/valve is typically designated as “guard.” An example is the outlet works for Theodore Roosevelt Dam, Arizona, where there is an emergency wheel-mounted gate upstream of guard ring-follower gates and regulating jet-flow gates.

**Design Standards No. 14: Appurtenant Structures for Dams
(Spillways and Outlet Works)**

- **For embankment dams and embankment portions of composite dams**, where the outlet works pass through the embankment dam, there are three preferred or acceptable gate/valve arrangements, and one least preferred gate/valve arrangement, which are illustrated by figures 4.3.5-2 through 4.3.5-5. There is also a fifth gate/valve arrangement that does not conform to arrangements 1 through 4 and can vary from acceptable to not acceptable, depending on the number, type, and location of gates/valves and whether the outlet works is pressurized. This arrangement is very common for modified conditions. These arrangements include:
 - **Arrangement 1.** Hydraulic control (regulating gates/valves) is located in a downstream control structure (near the downstream end of outlet works), and hydraulic control (emergency or guard gates/valves) is located in a control structure at/near the projected centerline of the dam/dike. Both upstream and downstream conveyance features are pressurized, with the downstream pressurized pipe inside a larger access conduit and/or tunnel (see figure 4.3.5-2). For an embankment dam, the furthest downstream extent of the reservoir head (pressurized conditions) would be at or upstream of the projected embankment core material (zone 1). Nonpressurized conditions (pressure pipe inside a larger access conduit and/or tunnel) would exist along the projected zoned filter materials (zones 2 and 3) for the embankment dam downstream of the reservoir hydraulic control (emergency or guard gates/valves). Examples of outlet works with gate/valve arrangement 1 include Glen Elder river outlet works, Choke Canyon Dam river outlet works, and Ridgway Dam river outlet works.
 - **Arrangement 2.** Hydraulic control (emergency or guard gates/valves and regulating gates/valves) is located in a control structure at/near the projected centerline of the dam. Upstream conveyance feature is pressurized, and downstream conveyance feature is free flowing (not pressurized) (see figure 4.3.5-3). For an embankment dam, the furthest downstream extent of the reservoir head would be at or upstream of the projected embankment core material (zone 1). Free-flow conditions would exist along the projected zoned filter materials (zones 2 and 3) downstream of the hydraulic control (emergency or guard gates/valves and regulating gates/valves). Examples of outlet works with gate/valve arrangement 2 include Big Sandy Dam river outlet works and Spring Creek Dam river outlet works.

Chapter 4: General Outlet Works Design Considerations

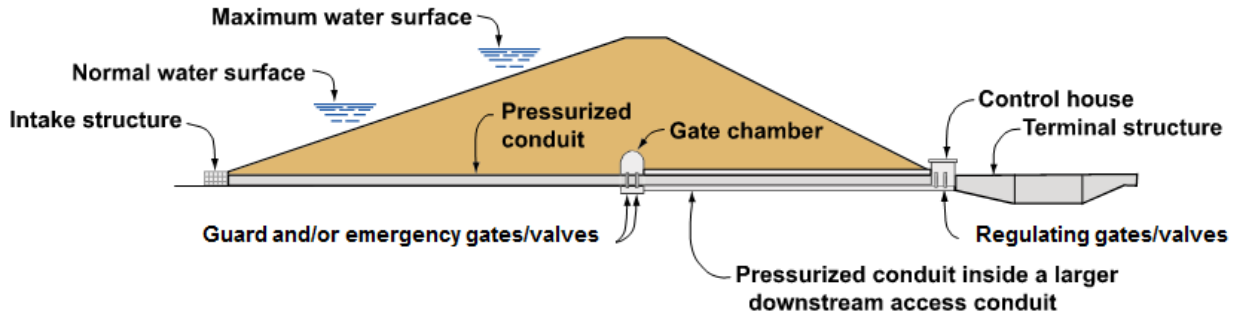

Figure 4.3.5-2. Arrangement 1 for embankment dams: Preferred outlet works configuration for embankment dams: hydraulic control at downstream control structure, with guard/emergency gate/valve at/near centerline of dam/dike, and downstream pressurized pipe (between dam/dike centerline and control structure inside larger access conduit).

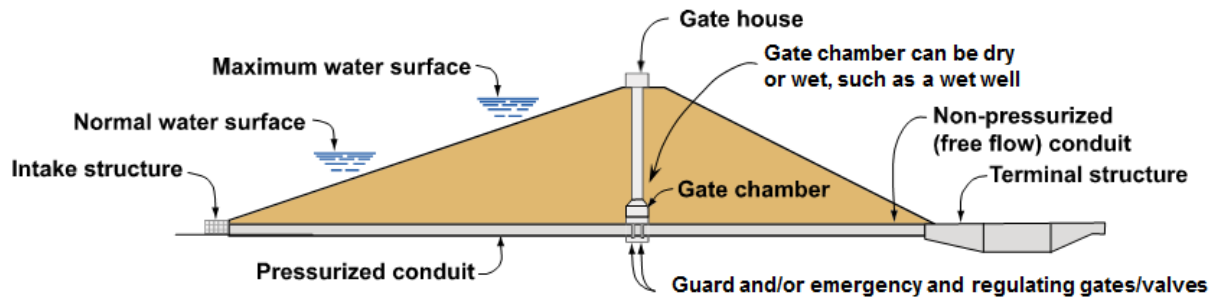

Figure 4.3.5-3. Arrangement 2 for embankment dams: Acceptable outlet works configuration for embankment dams: hydraulic control at/near centerline of dam/dike, with free-flow conditions downstream of the regulating gate/valve.

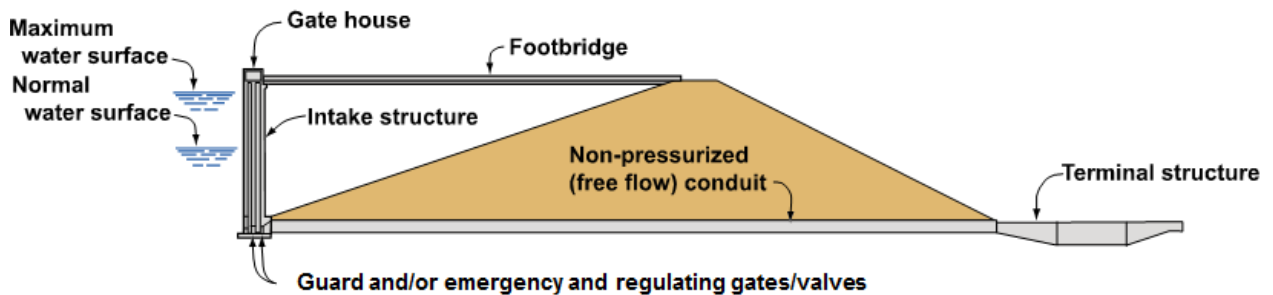

Figure 4.3.5-4. Arrangement 3 for embankment dams: Acceptable outlet works configuration for embankment dams: hydraulic control at upstream intake with free-flow conditions downstream of the regulating gate/valve.

**Design Standards No. 14: Appurtenant Structures for Dams
(Spillways and Outlet Works)**

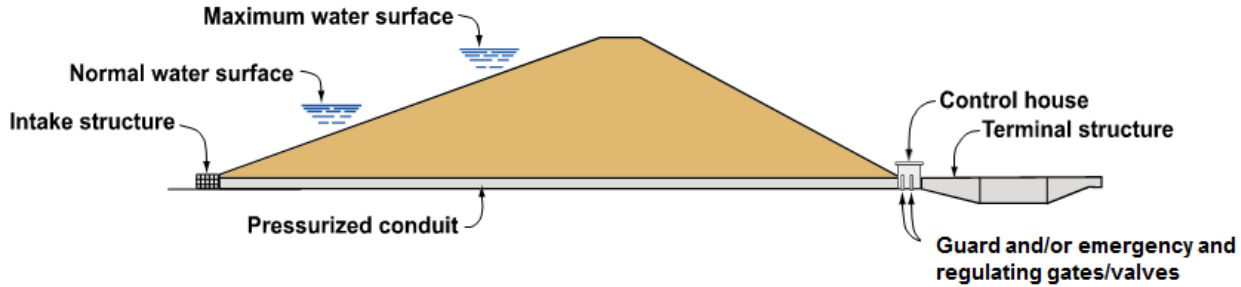

Figure 4.3.5-5. Arrangement 4 for embankment dams: Least acceptable outlet works configuration for embankment dams: hydraulic control at downstream control structure (i.e., pressurized flow conditions upstream of the regulating gate/valve along most of the outlet works). Additional design precautions/redundancies, such as steel-lined conduit, should be considered if this arrangement is pursued.

- **Arrangement 3.** Hydraulic control (emergency or guard gates/valves and regulating gates/valves) is located at/near the intake structure with free-flow conditions throughout the conveyance feature (downstream of the hydraulic control) (see figure 4.3.5-4). For an embankment dam, the furthest downstream extent of the reservoir head would be at/near the projected upstream slope of the embankment. Free-flow conditions would exist along most of the dam footprint. Examples of outlet works with gate/valve arrangement 3 include Crescent Lake Dam river outlet works, Kachess Dam river outlet works, and Lake Sherburne Dam river outlet works.
- **Arrangement 4.** Hydraulic control (emergency or guard gates/valves and regulating gates/valves) is located at the downstream end of the outlet works with pressurized flow conditions upstream of the hydraulic control (see figure 4.3.5-5). For an embankment dam, the furthest downstream extent of the reservoir head would be along most of the dam footprint (from the intake structure to the hydraulic control, which is at/near the downstream end of the outlet works). With few exceptions, this gates/valves arrangement should not be considered for an outlet works associated with an embankment dam. Examples of outlet works with gate/valve arrangement 4 include Anita Dam river outlet works and Washington Dam river outlet works.
- **Arrangement 5.** A fifth gate/valve arrangement has been used, which involves a hydraulic control (emergency or guard gate/valve) within the dam or on the upstream face of the dam. The conveyance feature is pressurized from the upstream dam face to a control structure that contains the regulating gate/valve. The control structure is typically located at or downstream of the downstream face of the dam. This gate/valve arrangement can be a combination of the previously noted gate/valve arrangements

Chapter 4: General Outlet Works Design Considerations

and tends to occur when an existing outlet works is modified, such as adding a pipe or penstock, which conveys water to a new location/ feature (municipality, powerplant, and canal) (similar to figure 4.3.5-9 for concrete dams). The acceptability of this arrangement for an embankment dam is dependent on the number, type, and location of gates/valves, redundancies in the conduit design, and whether the outlet works is pressurized. Examples of outlet works with gate/valve arrangement 5 include Cheney Dam M&I outlet works, French Canyon Dam river outlet works, and Vallecito Dam river outlet works.

- **For concrete dams and concrete portion of composite dams**, where the outlet works (sluiceways, M&I, power, and canal) pass through the concrete dam, there is more flexibility with gate/valve arrangements. The five gate/valve arrangements noted for outlet works that pass through embankment dams have been applied to outlet works that pass through concrete dams. These five gate/valve arrangements are generally acceptable with a preference for having the guard or emergency gate/valve located within the dam or on the upstream face of dam. Similar locations of the gate/valve arrangement apply to concrete dams as noted for embankment dams. These arrangements are illustrated by figures 4.3.5-6 through 4.3.5-9. Examples of each arrangement include:
 - **Arrangement 1.** Examples of outlet works with gate/valve arrangement 1 (similar to figure 4.3.5-2 for embankment dams) include American Falls Dam M&I outlet works and Stony Gorge Dam river outlet works.
 - **Arrangement 2.** Examples of outlet works with gate/valve arrangement 2 (see figure 4.3.5-6) include Davis Dam sluiceway, Pueblo Dam river outlet works (spillway), and Canyon Ferry Dam river outlet works.
 - **Arrangement 3.** Examples of outlet works with gate/valve arrangement 3 (see figure 4.3.5-7) include Brantley Dam river outlet works (low-flow) and Mountain Park Dam M&I (joint use) outlet works.
 - **Arrangement 4.** Examples of outlet works with gate/valve arrangement 4 (see figure 4.3.5-8) include Nambe Falls Dam river outlet works, East Canyon Dam river outlet works, and Monticello Dam river outlet works.
 - **Arrangement 5.** Examples of outlet works with gate/valve arrangement 5 (see figure 4.3.5-9) include Angostura Dam river outlet works and Glen Canyon Dam river outlet works.

**Design Standards No. 14: Appurtenant Structures for Dams
(Spillways and Outlet Works)**

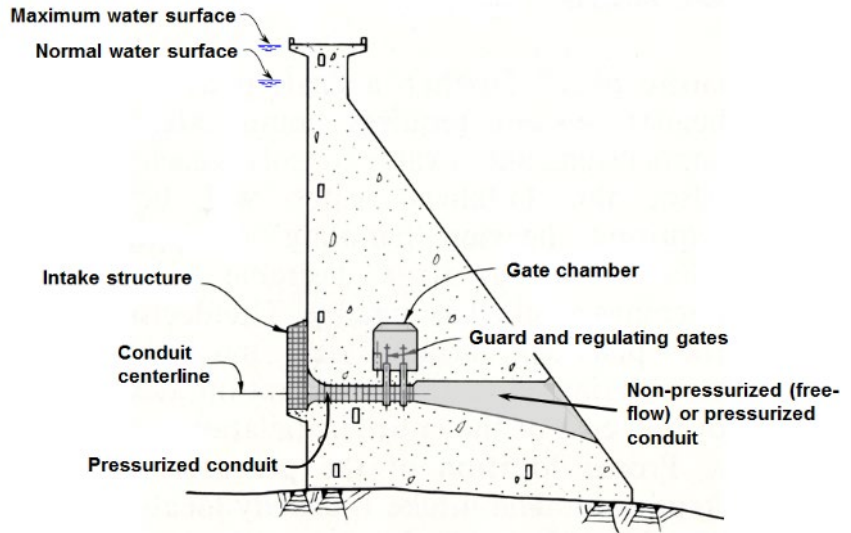

Figure 4.3.5-6. Arrangement 2 for concrete dams (typically applies to concrete gravity or thick arch dams): Acceptable outlet works configuration for concrete dams; hydraulic control within dam (gate chamber) with free-flow conditions downstream of the regulating gate/valve.

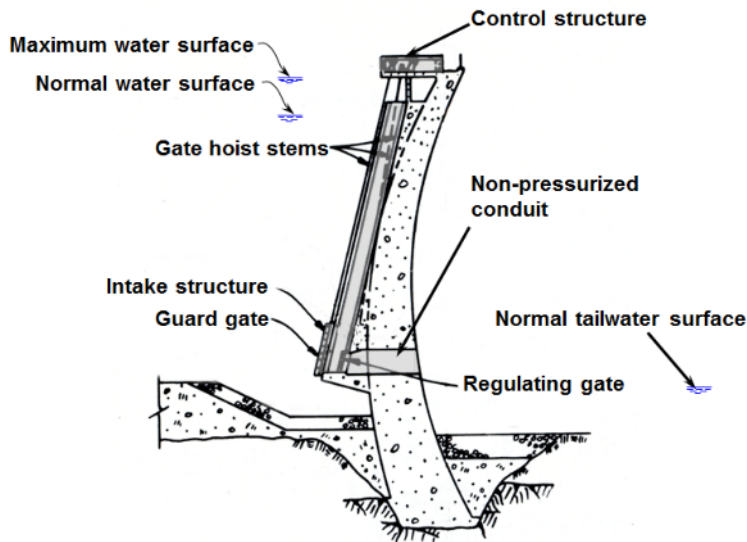

Figure 4.3.5-7. Arrangement 3 for concrete dams (applies to all types of concrete dams): Acceptable outlet works configuration for concrete dams; hydraulic control at upstream intake with free-flow conditions downstream of the regulating gate/valve.

Chapter 4: General Outlet Works Design Considerations

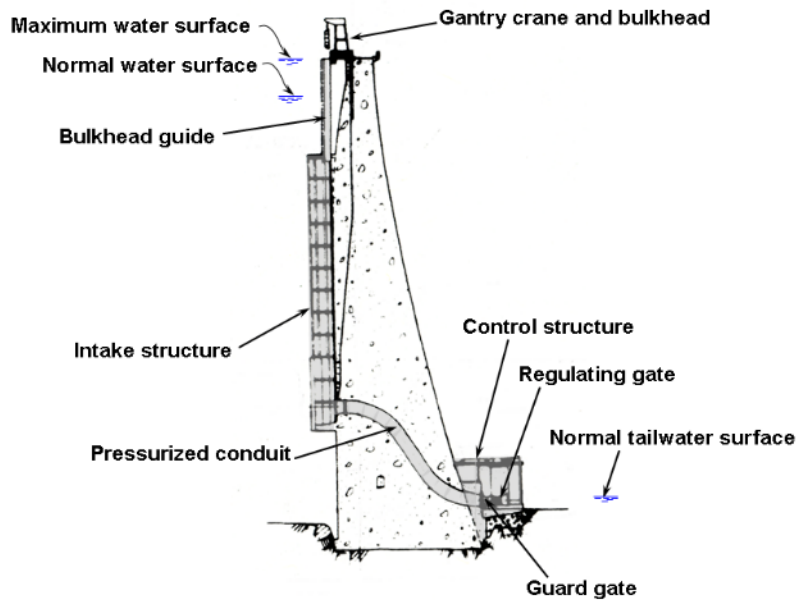

Figure 4.3.5-8. Arrangement 4 for concrete dams (applies to all types of concrete dams): Acceptable outlet works configuration for concrete dams if there are provisions for upstream bulkhead or gate/valve; hydraulic control at downstream control structure with pressure flow conditions from intake structure to the regulating gate/valve.

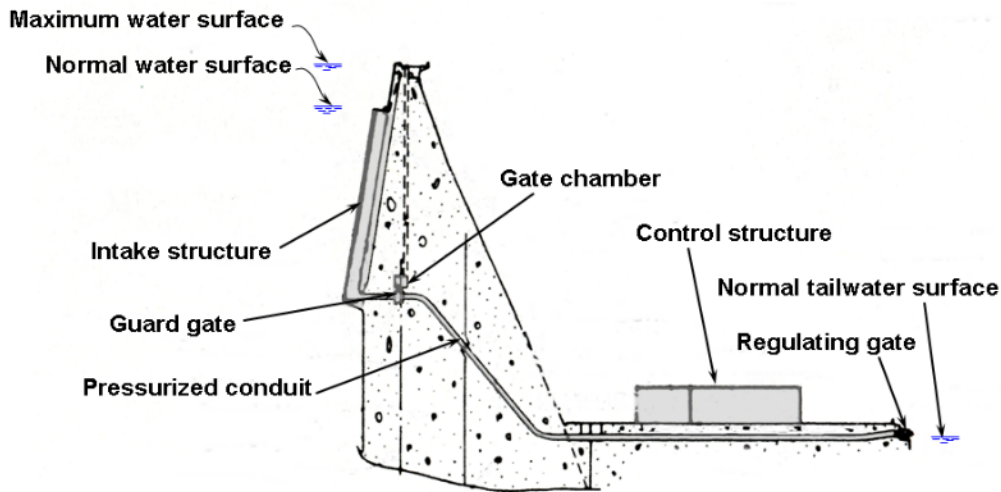

Figure 4.3.5-9. Arrangement 5 for concrete dams (applies to all types of concrete dams): Acceptable outlet works configuration for concrete dams; hydraulic control at downstream control structure and guard gate within dam (gate chamber) or on upstream dam face with pressure flow conditions from intake structure to the regulating gate/valve.

**Design Standards No. 14: Appurtenant Structures for Dams
(Spillways and Outlet Works)**

- **For tunnel outlet works adjacent to all types of dams (embankment, concrete, and composite)**, there is some flexibility with gate/valve arrangements, and those associated with embankment and concrete dams can be used. The five gate/valve arrangements noted for outlet works that pass through embankment and concrete dams have been applied to tunnel outlet works.

Similar locations of the gate/valve arrangement apply to tunnel outlet works, as noted for embankment and concrete dams. These five gate/valve arrangements for tunnels are treated similarly to the arrangement for embankment dams in terms of acceptability (i.e., arrangements 1 through 3 are generally acceptable; arrangement 4 should be avoided, if at all possible; and arrangement 5 may or may not be acceptable, depending on gate/valve location). Examples of each arrangement include:

- **Arrangement 1.** Examples of tunnel outlet works with gate/valve arrangement 1 include Bradbury Dam river outlet works, Mason Dam river outlet works, and New Waddell Dam river outlet works.
 - **Arrangement 2.** Examples of tunnel outlet works with gate/valve arrangement 2 include Owyhee Dam river (Tunnel No. 1) outlet works, A.R. Bowman Dam river outlet works, and El Vado Dam river outlet works.
 - **Arrangement 3.** Examples of tunnel outlet works with gate/valve arrangement 3 include Ruedi Dam (auxiliary) river outlet works.
 - **Arrangement 4.** Examples of tunnel outlet works with gate/valve arrangement 4 include Buffalo Bill Dam river outlet works and New Melones Dam river outlet works.
 - **Arrangement 5.** Examples of tunnel outlet works with gate/valve arrangement 5 include the four river outlet works associated with Hoover Dam and Theodore Roosevelt Dam river outlet works.
- **Bulkhead and stoplogs.** Bulkhead slots and, in some cases, stoplog slots, guides, or seats are provided on or near the intake structure, which results in the ability for future unwatering of the upstream conveyance feature (conduit or tunnel). Additionally, stoplogs and/or bulkhead slots or guides provided at the end of some terminal structures (such as hydraulic jump stilling basins) may be needed for future unwatering of the terminal

Chapter 4: General Outlet Works Design Considerations

structure. It should be highlighted that although many of Reclamation's outlet works have bulkhead seats or slots, careful evaluation must take place before installing the bulkhead and unwatering the outlet works. A number of potential issues may complicate unwatering the outlet works, including:

- Bulkhead seats or slots may have been designed for only limited (small) hydraulic heads, such as those associated with original construction of the outlet works. In this case, the bulkhead seat or slot may not be able to accommodate a full or nearly full reservoir.
- Bulkheads may not exist (i.e., they were never fabricated during original construction). Also, bulkheads may be shared by multiple dams and require scheduling and transporting to a given dam.
- The unwatered outlet works features (such as the intake structure and upstream conduit or tunnel) may not have been designed to accommodate external hydrostatic loads associated with a full or nearly full reservoir (i.e., hydrostatic loads could result in instability [floatation] or exceed the structural capacities of the outlet works features).

For more details about bulkhead and stoplogs, see Section 4.9, "General Electrical/Mechanical Considerations," of this chapter.

- **Isolate outlet works from embankment dam.** As previously noted in Section 4.3.1, "General," of this chapter, for embankment dams/dikes, isolate the outlet works from the dam/dike by one of the following three options:
 - The first option would include the outlet works conveyance feature (tunnel) through the dam/dike abutments or reservoir rim. This option is applicable to rock foundations.
 - The second option would be concrete encasement of outlet works conveyance feature (conduit) in a foundation notch across the dam footprint that would be below or outside the dam-foundation contact. This option is applicable to rock foundations.
 - The third and least desirable option would be locating the outlet works conveyance feature (conduit) along or near the foundation-dam contact (either near the riverbed or on an abutment). Embankment materials will encase the outlet works conveyance feature. The outlet works should be considered a potential discontinuity within the embankment, requiring special design and construction considerations to ensure compaction and filter criteria are met. This option is applicable to both rock and soil foundations.

4.4 Design Floods and Discharge Requirements

For storage or multipurpose dams, there are two primary hydrologic loadings and a number of discharge requirements that should be evaluated and will be factors in determining the location, type, and size of the outlet works.

4.4.1 Inflow Design Flood and Other Design Floods

In some situations, the outlet works will be used to help pass flood events. If this is the case, floods could determine the discharge capacity of the outlet works. The flood events could range from operational floods, which are typically more frequent than the IDF (such as the 100-year flood), to the IDF. For reference, the IDF is the maximum flood hydrograph, or ranges of hydrographs, used in the design of a dam and its appurtenant structures, particularly for sizing the dam, spillway, and outlet works. Features are designed to safely accommodate floods up to and including the IDF. The IDF will be equal to or smaller than the current critical PMF.⁹ As described in detail in Chapter 2, “Hydrologic Considerations,” of this design standard, selection of the IDF and other design floods for an existing and/or new dam is based on quantitative risk analysis methodology.

4.4.2 Construction Diversion Floods

The outlet works may be an important component of a diversion system used during construction. If this is the case, consideration must be given to safely passing both normal streamflow and flood events during the construction period (i.e., diverting flows through and/or around the construction area with no or limited impacts to construction efforts and the downstream area). Diversion methods are sized by balancing cost of the diversion method and the risk associated with a larger flood occurring than the flood used to size the diversion method. The process for identifying/selecting the construction diversion flood used to size the diversion method is described in detail in Chapter 2, “Hydrologic Considerations,” of this design standard.

⁹ It should be noted that more than one type of PMF can occur at a given dam site (rain-on-snow, thunderstorm, etc.), which leads to an important concept: the critical PMF. This flood event is defined as the PMF that would typically result in the highest maximum RWS.

4.4.3 Discharge Requirements

As discussed in Section 4.3.1, “General,” of this chapter, the discharge capacity for an outlet works is dictated by the intended purposes, such as irrigation, reservoir evacuation, flood, power generation, diversion, sediment release, and other release requirements (environmental enhancement and M&I needs). The size of the outlet works will be based on the maximum discharge requirement; however, the outlet works will need to provide a full range of release capability that satisfies all discharge requirements. In some cases, meeting all discharge requirements will result in very large to very small discharge releases. Rather than using large gates/valves to achieve small releases (which can result in adverse hydraulic conditions such as cavitation), a bypass system will be used. This bypass system will include smaller pressurized pipes and hydraulic controls (smaller gates/valves) that will meet small discharge requirements (see figure 4.4.3-1).

4.5 Outlet Works Location, Type, and Size

It is very important to understand that an outlet works is a key feature of a dam, and its location, type, and size will ensure reliable and safe reservoir operations.

4.5.1 Outlet Works Location

Consideration should be given to the location of the outlet works, which will be site specific, but there are some overarching considerations to keep in mind when locating outlet works.

4.5.1.1 Dam Abutments

Preferred locations for an outlet works are the dam abutments adjacent to or near the ends of the dam (especially for embankment dams). This would involve subsurface (tunnel) outlet works for embankment, concrete, and composite dams. Locating the outlet works would be dependent on topography, geology, and economics.

**Design Standards No. 14: Appurtenant Structures for Dams
(Spillways and Outlet Works)**

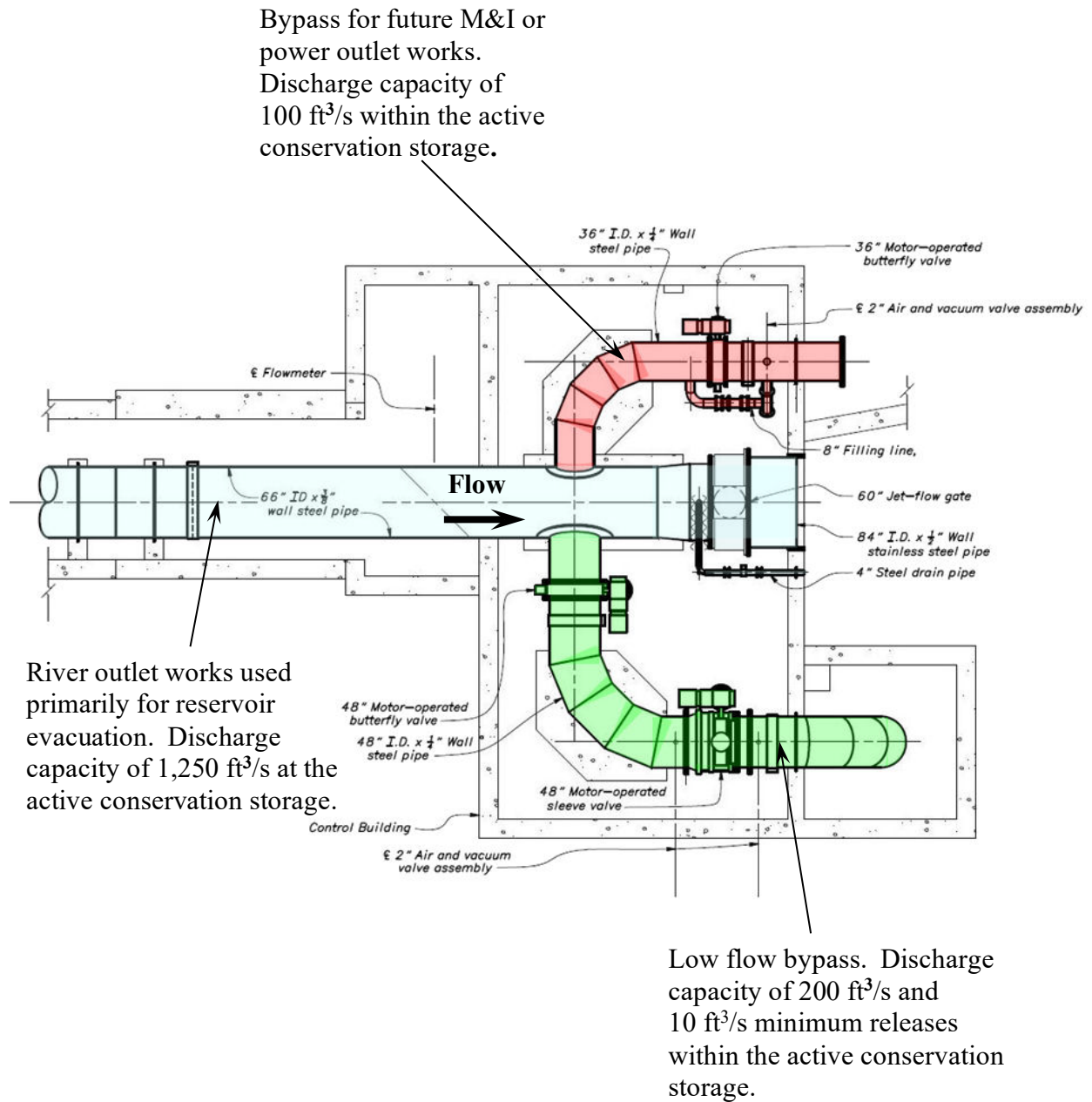

Figure 4.4.3-1. Outlet works – example bypass system associated with an Arrangement 1 hydraulic control plan view of downstream control structure.

4.5.1.2 Reservoir Rim

Another potential location for an outlet works is the reservoir rim (located away from the dam). This would involve subsurface (tunnel) outlet works for embankment, concrete, and composite dams. Locating the outlet works would be dependent on topography, geology, and economics. In a case where outlet works releases are made back into the natural stream or riverbed, rather than a pipeline, penstock, or canal, care should be taken to evaluate the exit channel and downstream area. There could be situations where locating an outlet works through the reservoir rim would allow releases to enter a different drainage area than that associated with the main river or stream. During outlet works operation, this could adversely impact downstream areas that were not subject to releases prior to the construction of the dam or outlet works. The downstream consequences (both property damage and potential life loss) will need to be fully evaluated before locating an outlet works that could release flows into a different drainage area or a tributary that enters the main waterway downstream from the dam.

4.5.1.3 Beneath/Outside the Foundation-Dam Contact

An acceptable location for an outlet works would be below or outside the dam foundation contact. As previously noted in Section 4.3.5, “Outlet Works Configuration,” of this chapter, this would involve constructing the outlet works in an excavated notch and encasing in concrete so that the outlet works is isolated from the dam. This location of the outlet works is applicable for embankment, concrete, and composite dams.

4.5.1.4 Through a Dam

The least acceptable location for an outlet works would be through (above or inside the foundation-dam contact) an existing or new embankment dam and/or dike, or the embankment portion of a composite dam, unless there are very unusual circumstances. An unusual circumstance might involve the dam abutments, the reservoir rim, and notching into the foundation, which does not offer technically feasible, cost-effective locations for an outlet works. As previously noted in Section 4.3.5, “Outlet Works Configuration,” of this chapter, the outlet works should be treated as a potential discontinuity within the embankment dam, requiring special design and construction considerations to ensure that compaction and filter criteria are met.

An outlet works can be located through (integral with) an existing or new concrete dam. Also, the concrete portion of a composite dam may be able to accommodate the outlet works. Locating the outlet works on or through the concrete dam, or the concrete portion of a composite dam, would be acceptable as long as it does not produce unacceptable stress concentrations associated with the dam. There may be both economic and technical reasons to have the outlet works

Design Standards No. 14: Appurtenant Structures for Dams (Spillways and Outlet Works)

integral with the dam, which could provide outlet works releases with the most direct path between the upstream reservoir and the downstream river or stream.

It should be pointed out that although outlet works have been placed in new conventional mass concrete dams without much disruption to construction operations, care must be taken when placing outlet works in new RCC dams to avoid significant impacts to construction (RCC placement) operations. This can be done by isolating the outlet works from RCC placement, which can be accomplished by encasing the outlet works in conventional concrete. The encased concrete is shaped to allow RCC placement on or adjacent to the encased outlet works (such an approach was used for the outlet works associated with Reclamation's Upper Stillwater Dam).

4.5.1.5 Outlet Works Foundations

An outlet works can be located on rock or soil foundations; however, locating an outlet works on a rock foundation, if it is available, is highly recommended. More robust design and construction considerations will be needed for a soil foundation. These considerations are further discussed in Section 4.7, "General Foundation Considerations," of this chapter.

4.5.2 Outlet Works Type and Size

Reclamation has historically identified an outlet works by its primary purpose, physical and structural arrangement, or hydraulic operations [5]. Some examples are:

- M&I and canal headworks are examples of identifying outlet works based on its primary purpose.
- A cut-and-cover or tunnel outlet works are examples of identifying outlet works based on physical and structural arrangements.
- Gated or ungated, pressurized or free-flow outlet works are examples of identifying outlet works based on hydraulic operations.

These approaches fully define the outlet works type. For more information, see the outlet works type chart (see figure 4.5.2-1).

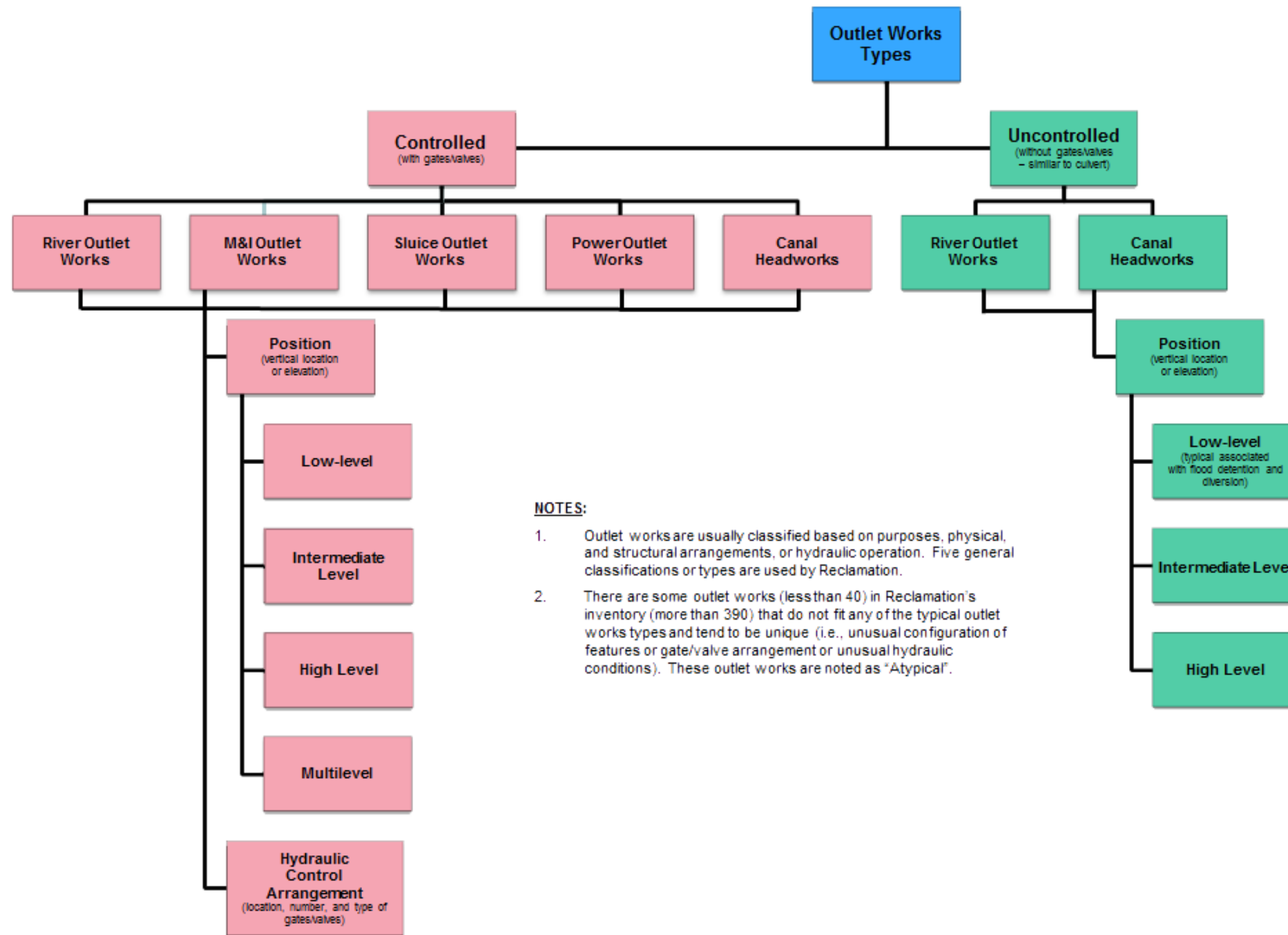

Figure 4.5.2-1. Outlet works type chart.

This page intentionally left blank.

4.5.2.1 Uncontrolled Outlet Works

Uncontrolled outlet works are typically limited to detention and diversion dams and would not be appropriate hydraulic structures for storage and/or multipurpose dams. For the most part, uncontrolled outlet works are low-level river outlet works associated with smaller dams and/or dikes that will pass flow at a limited rate directly into the river, stream, or drainage area immediately downstream of the dam. Also, there are some intermediate and high level canal headworks that are used to divert uncontrolled flows. Uncontrolled outlet works operate similarly to culverts. If additional information is needed about uncontrolled outlet works, refer to the *Design of Small Canal Structures* [18].

4.5.2.2 Controlled Outlet Works

Controlled outlet works associated with storage and/or multipurpose dams are typically classified into five types, which include river outlet works, M&I outlet works, sluice outlet works, power outlet works, and canal headworks (for more details, see Section 4.2.1, “Outlet Works,” of this chapter). Also, the controlled outlet works types are further defined by position or elevation and hydraulic control arrangement (for more details, see Section 4.3.4, “Relationship Between Reservoir Storage Levels and Outlet Works Position,” and Section 4.3.5, “Outlet Works Configuration,” of this chapter). In addition, the controlled outlet works types are defined by common features that were briefly touched on in Section 4.3.5, “Outlet Works Configuration,” of this chapter. These common features are discussed in more detail in the following sections.

4.5.2.2.1 Approach, Inlet, or Entrance (Upstream) Channel

This feature is typically associated with an outlet works that may be used for diversions during construction, which could be located very low in the reservoir, or it is associated with an outlet works (such as a canal headworks) that is located at a relatively high elevation. In some geologic and topographic settings, the approach channel may be vulnerable to clogging with sediment (which enters the reservoir from drainage area) with material from unstable excavated and natural slopes. Where the accumulation of such material occurs at or near the intake structure, plugging could result, leading to diminished discharge capacity [19]. Of note, the entrance channel flow velocities are usually less than flow velocities through the trashracks (2 to 5 ft/s), and the entrance channel is widened near the intake structure to permit a smooth, uniform flow into all trashrack openings [5].

4.5.2.2.2 Intake Structure

This feature forms the entrance to an outlet works. It typically includes auxiliary features, such as trashracks, fishscreens, and bypass systems, and it may include temporary diversion openings and provisions for installing a bulkhead or stoplogs. For additional details concerning trashracks, fishscreens, bulkheads, and

Design Standards No. 14: Appurtenant Structures for Dams (Spillways and Outlet Works) Design Standards

stoplogs, see Section 4.9, “General Electrical/Mechanical Considerations,” of this chapter. The selection of the type of intake structure is based on:

- The purpose(s) it serves (i.e., normal river/stream releases, reservoir evacuation, M&I, etc.).
- Range of reservoir head under which it operates.
- Frequency of reservoir drawdown.
- Anticipated level of trash and debris, which will have a bearing on frequency of cleaning trashracks and potential loading conditions.
- Anticipated ice and wave conditions.
- Hydraulic control arrangement (i.e., if some or all of the gates and/or valves are placed at the intake structure, an intake tower will likely be the selected type). For more details about hydraulic control arrangements, see Section 4.3.5, “Outlet Works Configuration,” of this chapter.

Common intake structures types for outlet works include:

- Intake tower, including selective level intakes (see figure 4.5.2.2.2-1)
- Drop inlet intake structure (see figure 4.5.2.2.2-2)
- Box intake structure (see figure 4.5.2.2.2-3)
- Front-entrance intake structure (see figure 4.5.2.2.2-4)
- Inclined intake structure, including selective level intakes (see figure 4.5.2.2.2-5)
- Trashrack intake structure (see figure 4.5.2.2.2-6)

Note: Although an intake structure typically associated with a concrete dam is identified as a trashrack structure, it should be noted that almost all intake structures have either trashracks or fishscreens, or both.

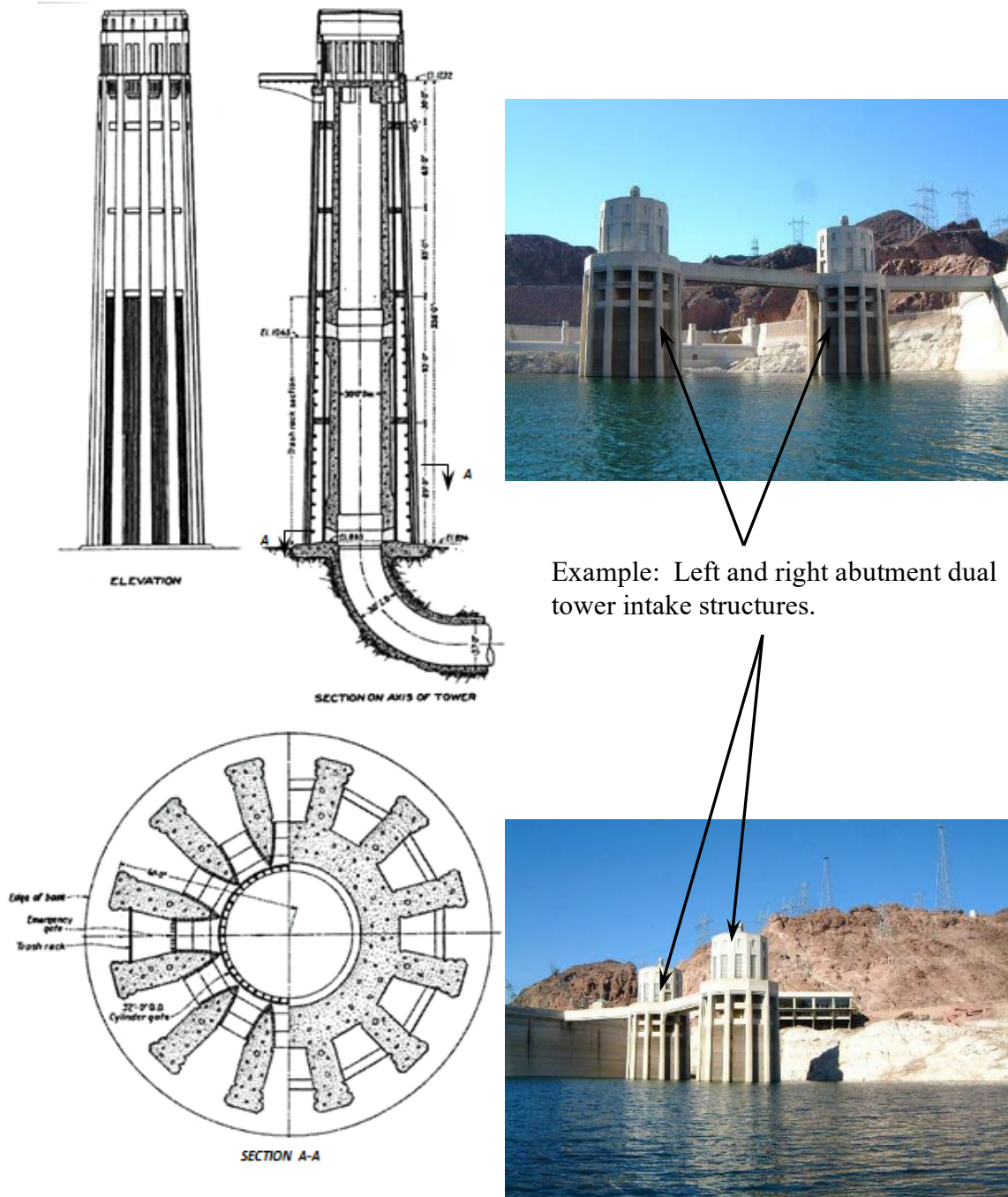

Example: Left and right abutment dual tower intake structures.

Figure 4.5.2.2-1. Examples: tower intake structure.

**Design Standards No. 14: Appurtenant Structures for Dams
(Spillways and Outlet Works) Design Standards**

Example: Drop inlet intake structure prior to first filling of reservoir.

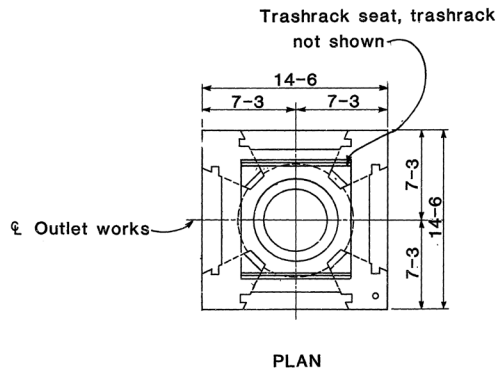

Approach channel



Centerline of upstream conduit to tunnel, which extends through abutment.

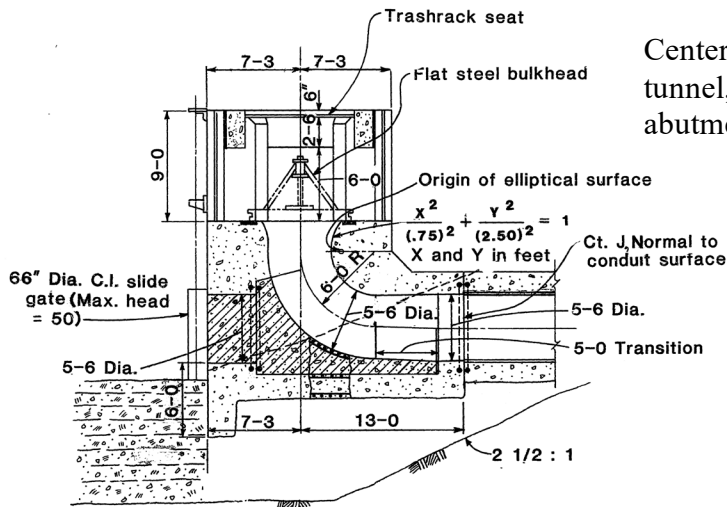
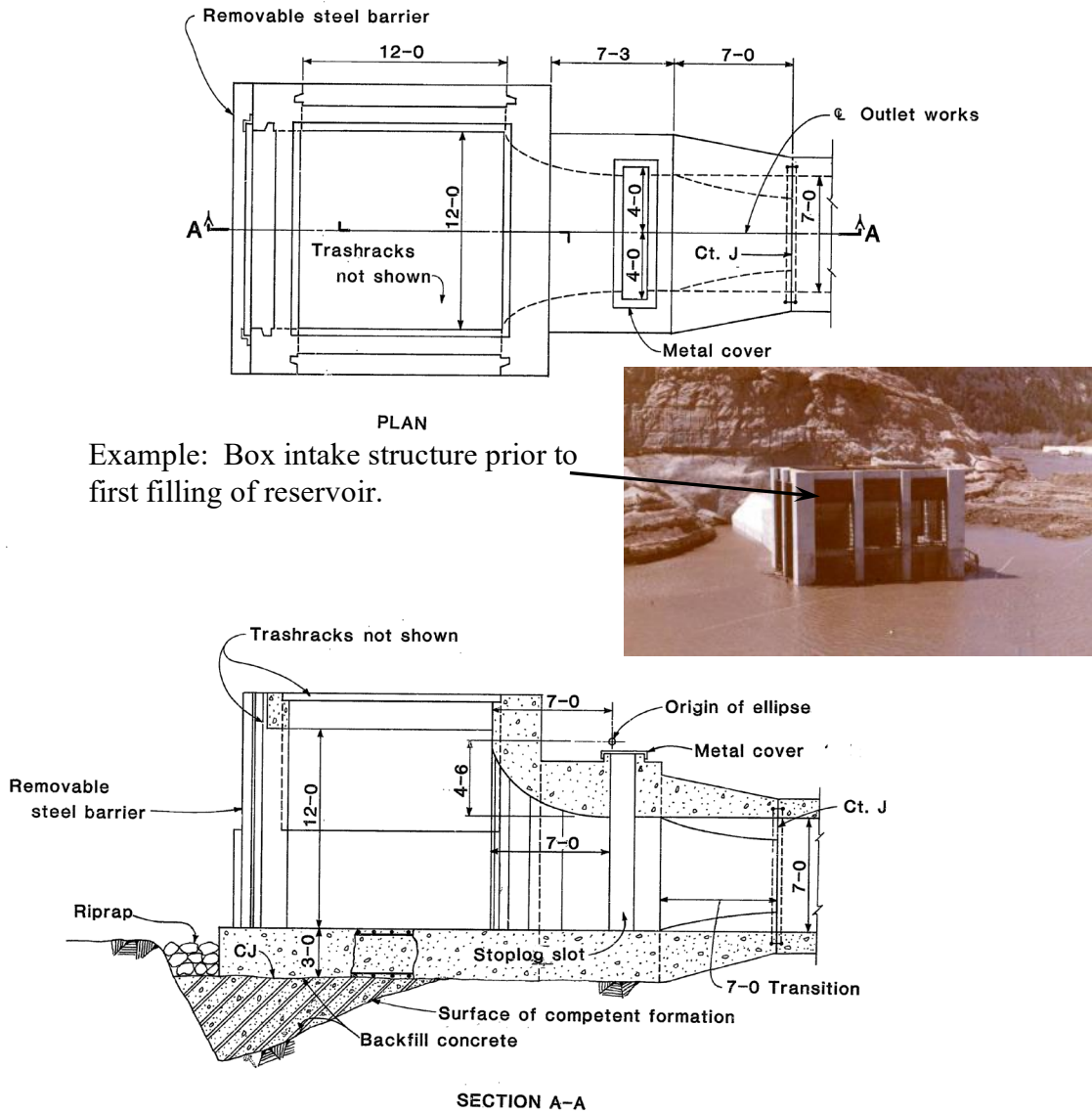

Figure 4.5.2.2-2. Examples: drop inlet intake structure.

Chapter 4: General Outlet Works Design Considerations



Example: Box intake structure prior to first filling of reservoir.

Figure 4.5.2.2-3. Examples: box intake structure.

**Design Standards No. 14: Appurtenant Structures for Dams
(Spillways and Outlet Works) Design Standards**

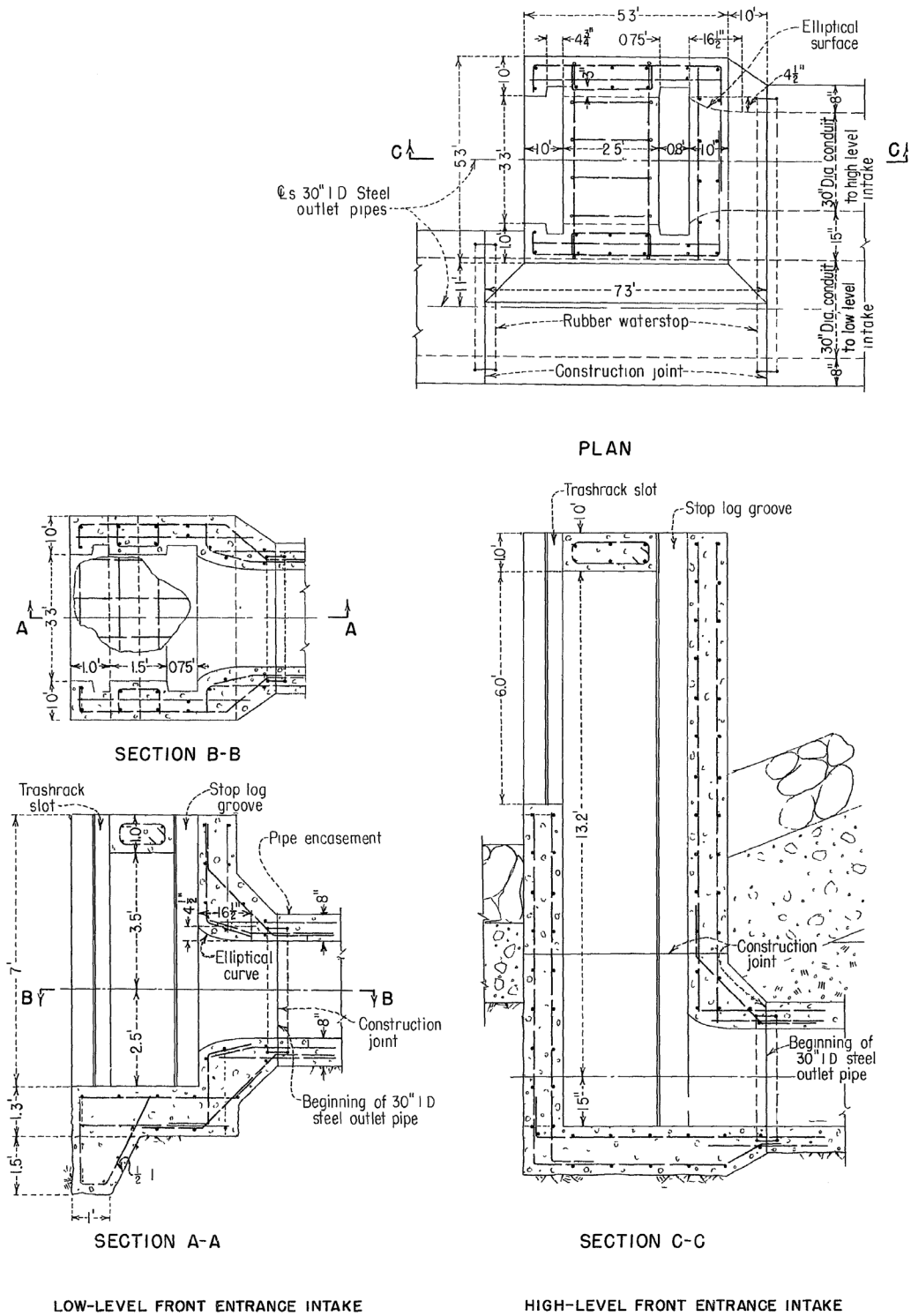
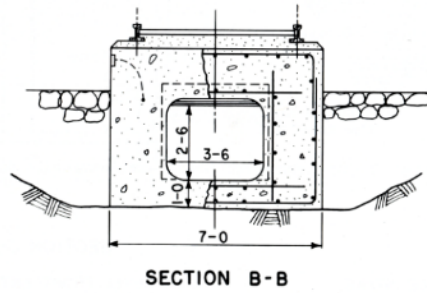
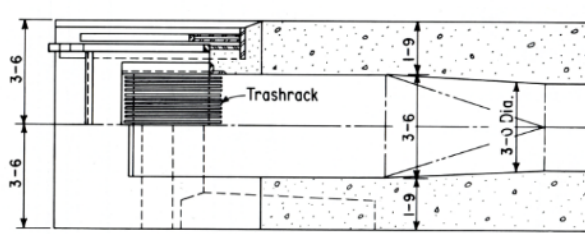
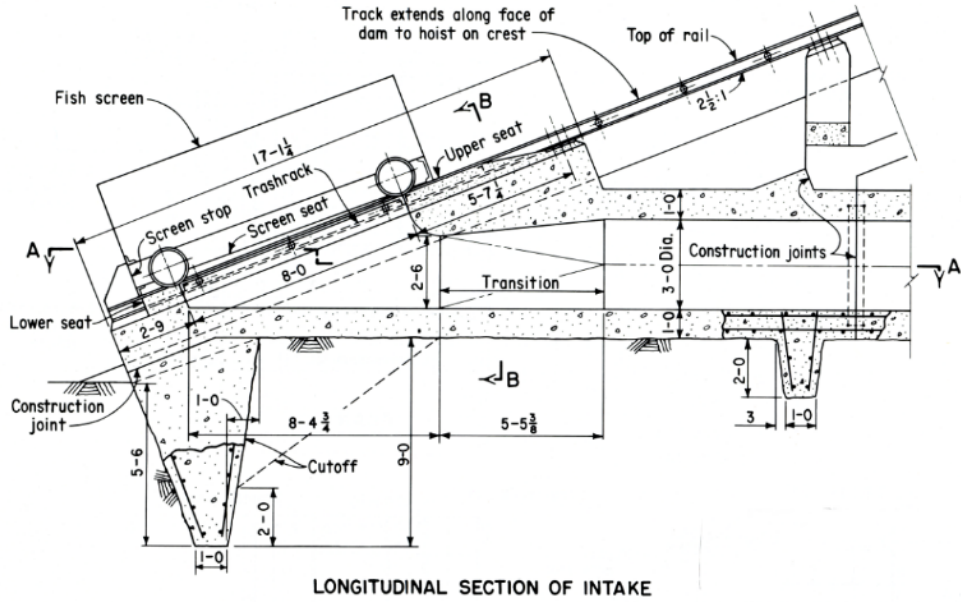

Figure 4.5.2.2-4. Examples: front-entrance intake structure.

Chapter 4: General Outlet Works Design Considerations



Example: Inclined intake structure located on upstream dam slope (exposed portion above the reservoir water surface).



Figure 4.5.2.2-5. Examples: inclined intake structure.

Design Standards No. 14: Appurtenant Structures for Dams (Spillways and Outlet Works) Design Standards

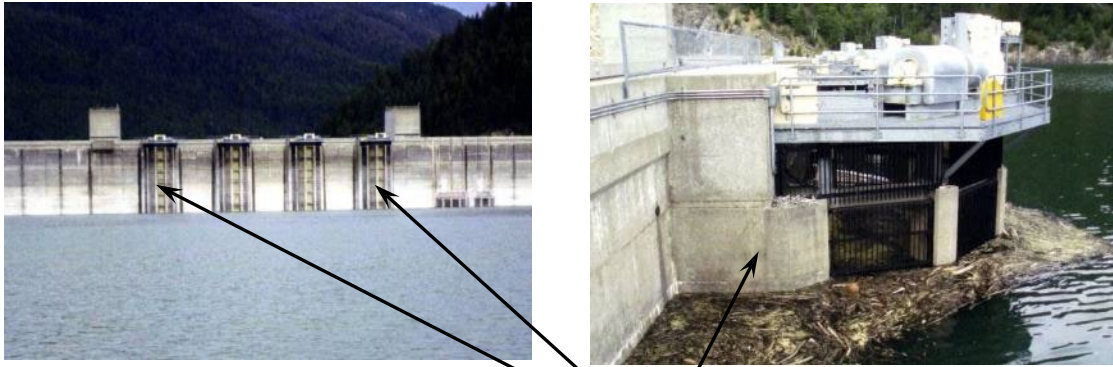

Example: Trashrack intake structures.

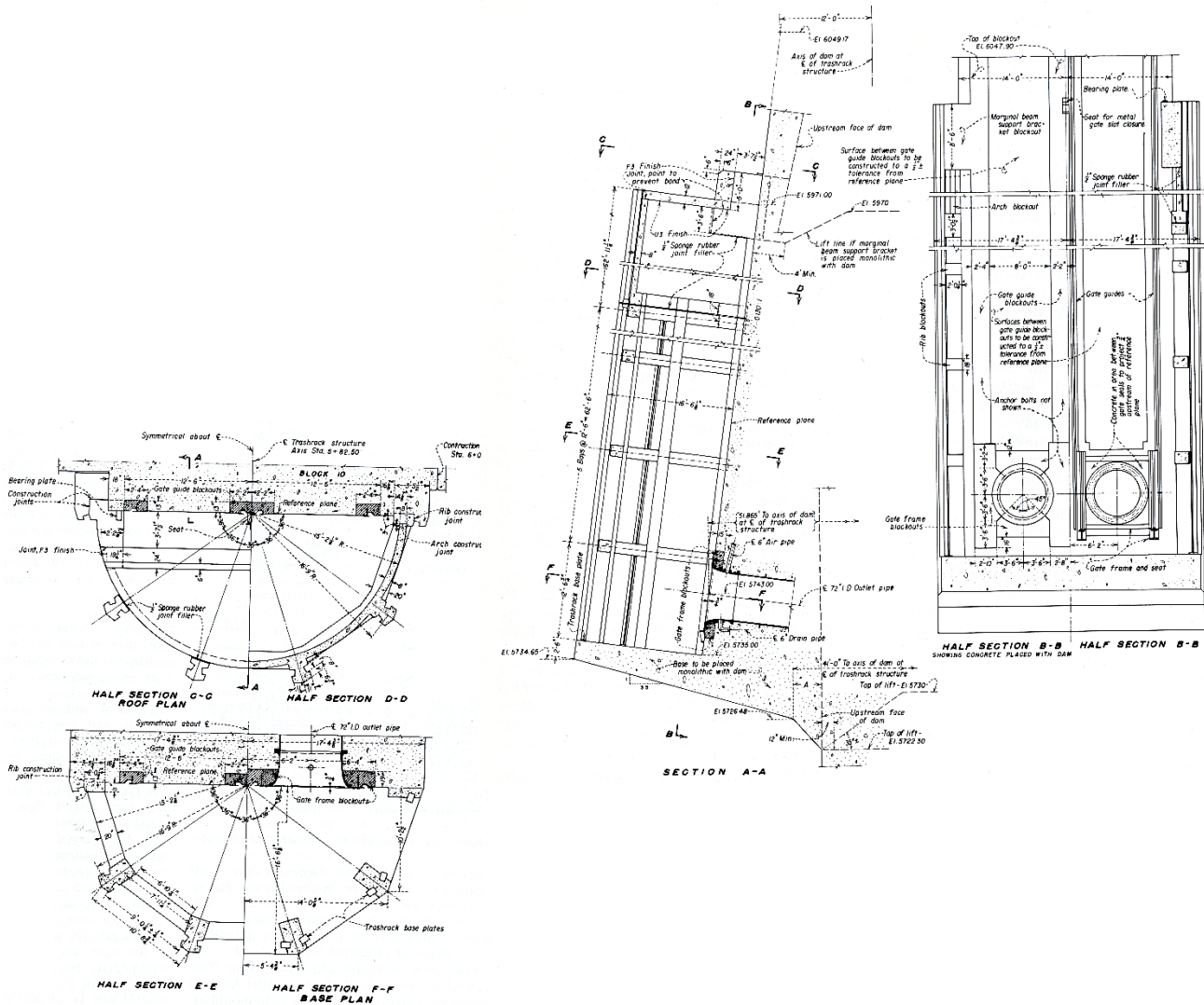

Figure 4.5.2.2-6. Examples: trashrack intake structure.

4.5.2.2.3 Conveyance Features

Although there are open channel conveyance features associated with some outlet works (appurtenant structures for low-head dams, high-level canal outlet works, and short chute sections that connect the downstream end of a conduit or tunnel to a terminal structure, such as hydraulic jump stilling basin), the majority of outlet works conveyance features associated with storage or multipurpose dams are tunnels and conduits, both pressurized and free-flow conditions. Depending on the hydraulic control arrangement (i.e., location of gates/valves), the outlet works conveyance feature may be a continuous tunnel or conduit connecting the intake structure to the control structure and/or terminal structure, or there could be upstream and downstream conveyance features that are separated by a control structure (such as a gate chamber and/or shaft, which is further discussed below in Section 4.5.2.2.4, “Control Structure,” of this chapter).

Shapes (cross sections) of tunnel and conduit conveyance features typically include:

- **For pressure tunnels and conduits**, a circular wetted cross section is the most efficient, both hydraulically and structurally.
- **For a free-flow tunnel and conduit**, a horseshoe wetted cross section or a flat bottom cross section (modified horseshoe) provides the best hydraulics but is not as structurally efficient as a circular wetted cross section.

The shapes Reclamation uses most frequently are illustrated in figure 4.5.2.2.3-1. It should be noted that other shapes have been used less frequently and include single, double, and triple barrel cross sections. To facilitate the selection and size of the shape, many shapes have been analyzed, resulting in reaction coefficients for bending moments, thrusts, and shears at selected locations along the centroidal axis of the conduits and tunnels. The reaction coefficients reflect multiple loading conditions, which represent most vertical (downward) and lateral (side) loads, along with foundation (upward) reactions that conduits and tunnels might experience [20, 21]. These reaction coefficients are used to structurally size the specific conduit or tunnel conveyance feature.

As previously mentioned, the types of outlet works conveyance features include tunnels, conduits, and chutes, which are further discussed in the following bullets.

**Design Standards No. 14: Appurtenant Structures for Dams
(Spillways and Outlet Works) Design Standards**

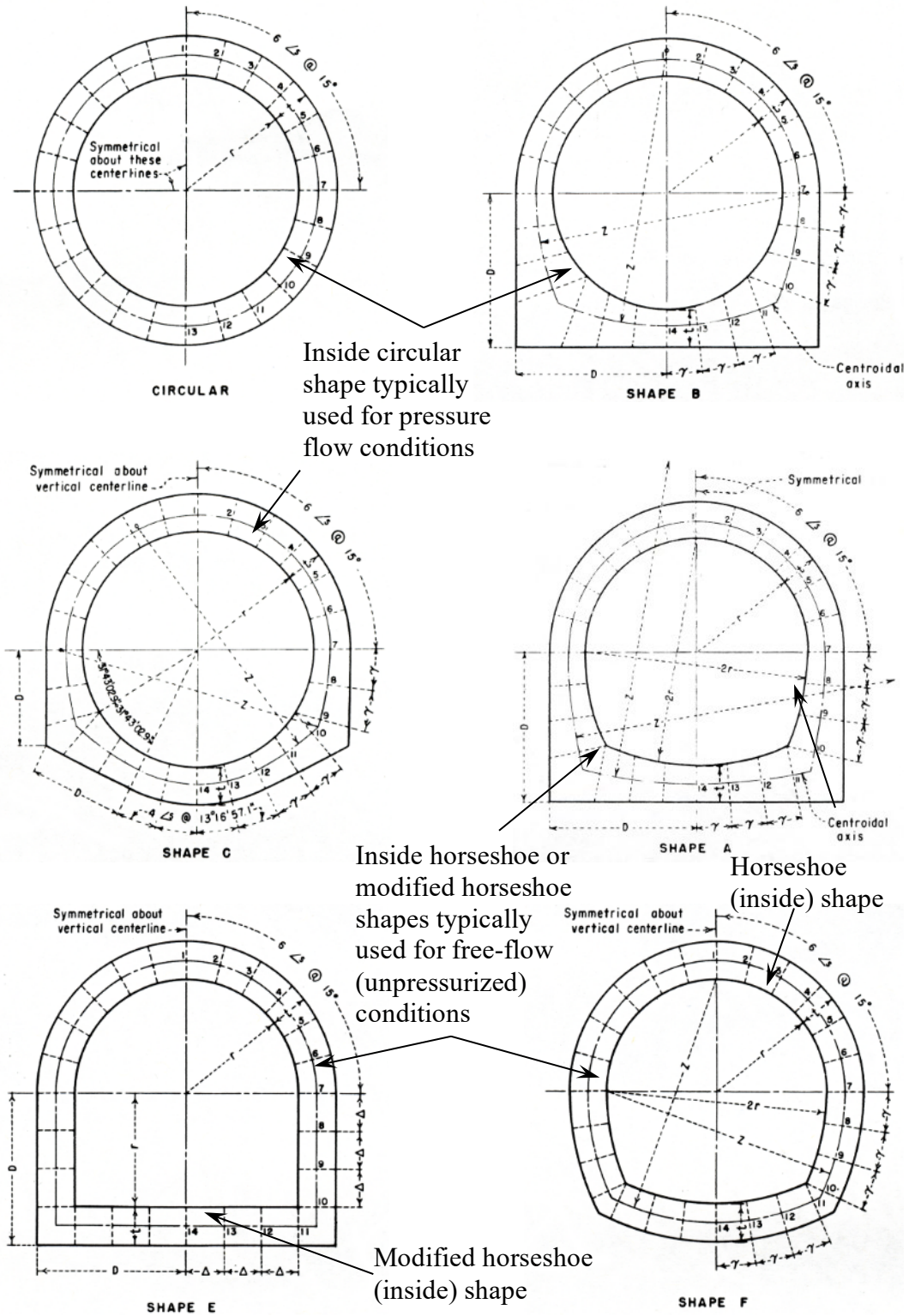

Figure 4.5.2.3-1. Conveyance feature shapes (cross sections) most used for both conduits and tunnels.

- **Tunnels.** These conveyance features can be used as part of an outlet works associated with concrete, embankment, and composite dams. As a general rule, it is not practical to build tunnels smaller than about 7 feet inside diameter because it makes accessing, inspecting, and repairing difficult. Particularly as a feature of an appurtenant structure for an embankment dam, tunnels are preferred over conduits through or under the dam, whenever tunneling through abutments and/or foundations is considered feasible and economically competitive with other conveyance features. When deciding whether to locate tunnels through the abutments or foundations of an embankment dam, versus locating conduits through or beneath an embankment dam, consider the following important factors:
 - Because a tunnel is isolated from the embankment dam (i.e., encased in rock), it is much less prone to internal erosion than a conduit through or beneath an embankment dam.
 - Limited or no foundation settlement, differential movement, or structural displacement would be typically expected for a tunnel that is encased in rock.

With a few exceptions, lining of the tunnel conveyance feature (shotcrete, reinforced and/or unreinforced concrete, and steel) is typically included for an outlet works associated with a storage and/or multipurpose dam. The need to line the tunnel, and the types of lining to be used, are based on the following:

- For pressure tunnels with average velocities exceeding 5 ft/s, lining is recommended to prevent damage to downstream gates/valves from tunnel muck fines and rockfalls [22].
- For pressure tunnels in competent rock which can withstand full internal hydrostatic pressure (i.e., no possibility of a “blowout”), only limited lining may be needed. The lining may be unreinforced concrete or shotcrete. When the rock is less competent, more robust lining should be considered [5]. The lining is typically reinforced concrete and may also include steel lining. A steel liner is typically used in a pressurized tunnel downstream of the grout curtain associated with a dam and prevents pressurized seepage flow from entering the surrounding rock formation. This is more critical for an outlet works located in an embankment dam abutment where pressurized flow from the tunnel may pass through joints or cracks in the rock formation and reach the embankment dam contact downstream of the embankment impervious zone.

**Design Standards No. 14: Appurtenant Structures for Dams
(Spillways and Outlet Works) Design Standards**

- For pressure tunnels where provisions are made to periodically unwater the tunnel by use of gates/valves, bulkheads, and/or stoplogs, it is appropriate to line the entire cross section. The lining is intended to accommodate the external rock and hydrostatic loads, along with protecting inspection personnel from rockfalls and/or collapse of a portion of the tunnel [5]. Design considerations should be given to unwatered tunnels safely accommodating external loads. Of note, before unwatering a pressure tunnel to inspect it, verify that the lining can accommodate the external loads (rock and hydrostatic). If there is any question about the stability and/or structural integrity of the unwatered tunnel lining, other methods of inspecting (such as remote operating vehicles [ROV]) should be pursued. The lining is typically reinforced concrete.
- For free-flow tunnels in competent rock, lining may only be needed along the sides and floor to form a smooth waterway. When the rock is less competent (i.e., possibility of rockfalls), it is appropriate to line the entire cross section [5] to accommodate external rock and hydrostatic loads, as well as to protect inspection personnel from rockfalls and/or collapse of a portion of the tunnel. The lining is typically reinforced concrete.
- For a portion of free-flow tunnels adjacent to the reservoir or immediately downstream of a pressure tunnel, it may be necessary to combine lining with grouting and/or drainage to address hydrostatic pressure buildup [5]. The lining is typically reinforced concrete and may also include steel lining.
- When the tunnel serves as access and containment for a smaller pressure pipe, it is common practice to line the entire cross section to protect the pressure pipe and operating personnel from rockfalls. The lining also limits seepage and protects the pressure pipe, along with any lighting and electrical equipment [5]. The lining is typically reinforced concrete.

Other considerations associated with steel pipe lining or other types of lining, such as high density polyethylene (HDPE) pipe or cured-in-place pipe (CIPP) for reinforced conduit conveyance features, include:

- Steel liners and/or embedded pipe are commonly used to form and structurally reinforce entrances, transitions, separations (wyes, bifurcations, etc.) and combinations (merging of two or more conveyance features), and gate/valve bodies.

Chapter 4: General Outlet Works Design Considerations

- Steel liners, steel pipes, and other types of liners have been and are effective modifications to existing outlet works conveyance features that have deteriorated over time or are structurally deficient.

For additional details concerning tunnels, see Chapter 4, “Tunnels, Shafts, and Caverns,” of *Design Standards No. 3, “Water Conveyance Facilities, Fish Facilities, and Roads and Bridges* [23].

- **Conduits.** These conveyance features can be used as part of an outlet works associated with concrete, embankment, and composite dams. As a general rule, if the conduit will be accessed for future inspections and/or maintenance by personnel, it should be no smaller than 5 feet in diameter. General considerations for locating conduits include:
 - For concrete dams, conduits within dams should be located away from the upstream-downstream contraction joints (CrJs) separating the dam blocks (monoliths).
 - For concrete dams, depending on the purpose of the outlet works, geometry of the dam, and location of the downstream waterway (river, canal, pipeline, etc.), the conduits can be located in either overflow or nonoverflow monoliths.
 - For concrete dams, the conduits can be located beneath or outside the concrete dam-foundation contact, in an excavated notch or channel, and encased in concrete.
 - For embankment dams with rock foundations, the conduits can be located beneath or outside the embankment dam-foundation contact, in an excavated notch or channel, and encased in concrete.
 - For embankment dams with rock or soil foundations, where the conduits must be located through or below the dam, considerations include:
 - Embankment height (above the conduit) is limited to 150-200 feet due to structural considerations.
 - Seepage cutoff collars should never be used. In lieu of these features, seepage along the conduit will be controlled by careful selection of embankment materials, special attention to placement and compaction of the embankment materials, and placement of a properly graded filter zone to safely convey any seepage out of the embankment surrounding the conduit [24, 25].

**Design Standards No. 14: Appurtenant Structures for Dams
(Spillways and Outlet Works) Design Standards**

- Conduits should have a reasonably smooth outside surface that is free from projecting or indented features, which could hinder compaction of embankment material against the conduit. This is particularly important in the impervious core zone of an embankment dam. Whenever possible, the sides of the conduit should be sloped approximately 1:10 (horizontal to vertical) for the conduit section that extends through the impervious zone of the embankment dam. The sloping sides will facilitate compaction directly against the conduit using pneumatic-tired rollers or other approved equipment. The intent is to minimize hand-operated power tampers (i.e., eliminate or minimize special compaction¹⁰) [24, 25]. Also, an excavated channel should be wide enough to allow for backfill compaction parallel to the conduit. Finally, the excavated slopes in a channel should be no steeper than 2:1 within the impervious zone of the embankment dam.
- For embankment dams with pressure conduits, design considerations should be given to the unwatered conduit safely accommodating external loads (soil and hydrostatic). Of note, when access is required, verify that the conduit can accommodate external loads. If there is any question about the stability and/or structural integrity of the unwatered conduit, other methods (such as an ROV) should be pursued.

Considerations should be given to steel pipe lining, steel pipes, or other types of lining, such as HDPE pipe or CIPP for reinforced conduit conveyance features, pertaining to:

- Steel liners and/or embedded pipes are commonly used to form and structurally reinforce entrances, transitions, separations (wyes, bifurcations, etc.) and combinations (merging of two or more conveyance features), and gate/valve bodies.
- Steel liners and/or embedded pipes should be considered as a design feature when there is the potential for significant foundation settlement. Also, as previously noted, when an outlet works is located adjacent to or through an embankment dam, steel liner and/or steel pipe should be considered at least through the projected

¹⁰ Special compaction should be minimized or excluded to reduce the potential for a change in compactive effort (between the special compaction and pneumatic-tired rollers) and/or variable or poor compaction associated with special compaction efforts. This could lead to weak zones and seepage paths in the embankment materials that parallel the outlet works conduit.

impervious core zone of the embankment dam. Finally, a more robust and preferred design would include extending the steel liner through the entire portion downstream of the impervious zone of the embankment dam.

- Steel liners, steel pipes, and other types of liners (i.e. HDPE or CIPP) have been and are effective modifications to existing outlet works conveyance features that have deteriorated over time or are structurally deficient.
- **Chutes.** These conveyance features can be used as part of an outlet works associated with concrete, embankment, and composite dams. They are primarily used to transition from a conduit or tunnel to a terminal structure such as the river outlet works at Reclamation's Twitchell Dam (see figure 4.5.2.2.3-2). Also, the chute may serve as a combined outlet works and spillway conveyance feature such as the sluices that release water into the spillway chute at Reclamation's Shasta Dam (see figure 4.5.2.2.3-2).

4.5.2.2.4 Control Structure

This feature contains the gates/valves and, depending on the gate/valve arrangement (location), could be part of the intake structure (Arrangement 3), such as the sluice outlet works at Reclamation's Elephant Butte Dam and the river outlet works at Bumping Lake Dam; a stand-alone structure located downstream of the intake structure (Arrangements 1 and 2), such as the river outlet works at Reclamation's McPhee Dam and Taylor Park Dam; or part of the terminal structure (Arrangement 4), such as the river outlet works at Reclamation's Anita Dam. The types of control structures include gate chambers with access shafts or access conduits/tunnels and gate houses (Arrangements 1 and 2) and control houses (Arrangements 1, 4, and 5). Along with including the gates/valves, the control structure could include bypass systems and access to the conveyance features. For additional details concerning gates/valves, see Section 4.9, "General Electrical/Mechanical Considerations," of this chapter).

4.5.2.2.5 Terminal Structure

This feature dissipates the kinetic energy associated with high velocity water exiting the conveyance feature. The selection of the type of terminal structure is based on:

- The purpose(s) it serves (i.e., normal river/stream releases, reservoir evacuation, M&I, etc.).
- Range of reservoir head under which it operates.
- Maximum and minimum discharge requirements.

**Design Standards No. 14: Appurtenant Structures for Dams
(Spillways and Outlet Works) Design Standards**



•
Three-tiered
sluice outlet

Combined outlet works and spillway chute.



Outlet works chute.

Figure 4.5.2.3-2. Examples: chutes associated with outlet works.

Chapter 4: General Outlet Works Design Considerations

- Flow velocity and depth.
- Downstream channel conditions (i.e., geology, tailwater).
- Hydraulic control arrangement. For more details about hydraulic control arrangements, see Section 4.3.5, “Outlet Works Configuration,” of this chapter.
- Site conditions, such as harsh, cold climates. In a cold climate where frequent winter operations may be needed, a terminal structure that produces less spray may be desirable to reduce ice buildup.

Common terminal structure types for outlet works include:

- Hydraulic jump stilling basin (see figure 4.5.2.2.5-1), such as the river outlet works at Palisades Dam and Silver Jack Dam.
- Impact basin (see figure 4.5.2.2.5-1), such as the four river outlet works at Reach 11 detention dikes.
- Stilling well (see figure 4.5.2.2.5-1), such as the river outlet works at Rattlesnake Dam and Sugar Pine Dam.
- Combined spillway-outlet works terminal structure (see figure 4.5.2.2.5-1), such as the river outlet works at Agency Valley Dam and the sluiceway at Grand Coulee Dam.
- Plunge pool (see figure 4.5.2.2.5-1), such as the river outlet works at Crystal Dam, Morrow Point Dam, and El Vado Dam.

4.5.2.2.6 Exit, Outlet, or Discharge (Downstream) Channel

This feature may be required to convey discharges from the terminal structure to the river/stream. The channel dimensions and the need for erosion protection (such as riprap) should be based on the nature of the material through which the channel is to be excavated [5].

4.5.2.3 Considerations for Selecting Outlet Works Type and Size

The general considerations for selecting the type and size of a new outlet works and/or modifying an existing outlet works include: project requirements (frequency and duration of operation, which, in some cases, could involve flood control requirements), dam type (concrete, embankment, composite), site conditions (topography, geology, climate, etc.), hydrologic and seismic loading requirements, meeting release requirements such as diversion during construction, irrigation, M&I, power generation, and reservoir evacuation. Essential considerations for selecting the type and size of a new outlet works and/or modifying an existing outlet works are summarized in table 4.5.2.3-1.

**Design Standards No. 14: Appurtenant Structures for Dams
(Spillways and Outlet Works) Design Standards**

Hydraulic jump stilling basin terminal structure (type II).



Double chamber impact basin terminal structure (type VI).

Triple chamber stilling well terminal structure.



Spillway chute

Outlet works exit portal

Combined spillway-outlet works terminal structure (type II with wave suppressor).



Plunge pool at base of dam.

Figure 4.5.2.2.5-1. Examples: terminal structures associated with outlet works.

Table 4.5.2.3-1. Considerations for Selecting Outlet Works Type and Size

Functional Considerations	Safety Considerations
1. Adequate discharge capacity to meet all requirements, such as diversion during construction, irrigation, M&I, power generation, and reservoir evacuation. Also, in some cases where the outlet works will be used to help pass flood events, adequate discharge capacity to safely accommodate floods up to and including the IDF (see Chapter 2, “Hydrologic Considerations,” of this design standard for procedures for selecting the IDF).	1. High operating reliability.
2. Compatible with type of dam and/or dike.	2. Structurally capable of safely accommodating normal operations and earthquake loadings; i.e., credible static and seismic potential failure modes risk estimate contributions to the total risks are acceptable (see Appendix B, “Potential Failure Modes (PFMs) for Outlet Works,” of this chapter).
3. Satisfies project requirements, such as operational release requirements associated with the RCA, discharge capacities of downstream dams, and channel capacity.	3. Hydraulically capable of safely releasing flows for any required uses which, in some cases, could involve flood releases up to and including the IDF; i.e., credible hydrologic potential failure modes risk estimate contributions to the total risks are acceptable (see Appendix B, “Potential Failure Modes (PFMs) for Outlet Works,” of this chapter).
4. Effectively uses site topography and geology.	
5. Cost-effective structure.	

4.5.2.4 Procedure for Selecting Outlet Works Type and Size

A general procedure is used to select the type and size of a new outlet works and/or modify an existing outlet works. This procedure is intended to provide guidance and may not be suited to every situation (i.e., in some cases, the selection of the outlet works type and size can be made without performing all the steps). For those outlet works that will be used to help pass flood events, this procedure is integral with the IDF selection process for both existing and new dams discussed in Chapter 2, “Hydrologic Considerations,” of this design standard. Specifically, the process includes: assuming an IDF; identifying and sizing the outlet works in combination with sizing the spillway, and reservoir surcharge that would safely accommodate the assumed IDF; estimating and

**Design Standards No. 14: Appurtenant Structures for Dams
(Spillways and Outlet Works) Design Standards**

determining if total risks are acceptable for the assumed IDF; and if not, repeating the previous steps until the total risks are acceptable. Additionally, the outlet works type and size must meet any other required uses such as diversion releases during construction, irrigation releases, power releases, and reservoir evacuation. The previously noted activity is outlined in table 4.5.2.4-1.

Table 4.5.2.4-1. Procedure for Selecting Outlet Works Type and Size

Step 1 (Discharge-Storage Balance)	Determine several combinations of outlet works releases (in combination with other hydraulic structure releases, if appropriate) and reservoir normal storage and flood surcharge storage (if applicable) required to meet all uses, such as diversion during construction, irrigation, M&I, power generation, reservoir evacuation, and, in some cases, help safely accommodate floods up to the IDF. Note: It may be necessary to consider that the downstream safe channel capacity may be exceeded during flood events and reservoir evacuation.
Step 2 (Configuration and Hydraulic Control Arrangement)	Identify preliminary outlet works configuration and hydraulic control arrangement that will meet the release requirements and any downstream release restrictions in combination with other hydraulic structures (if appropriate), and reservoir normal and flood storage requirements. This step may involve hydraulic analysis and design (discharge capacity estimates, flood routings, reservoir evacuation, water surface profiles, etc.), along with some preliminary structural and foundation analysis and design.
Step 3 (Preliminary Layout)	Lay out and evaluate the preliminary outlet works alternatives to verify that size and type will work for site conditions and meet project requirements.
Step 4 (Viable Outlet Works)	Identify the preliminary outlet works that will meet the release requirements in combination with normal reservoir and flood storage requirements.

The outlet works type and size resulting from this procedure must be further evaluated to determine if total risks are acceptable. Once it has been determined that total risks are acceptable, nonrisk factors (such as cost) are evaluated to refine the outlet works type and size. Final selection of the outlet works type and size will be based on both risk and nonrisk factors. For more details concerning evaluating both risk and nonrisk factors, see Table 4.3.2.2-1, “Procedure for Outlet Works Design Using Quantitative Risk Analysis,” of this chapter.

4.5.3 Examples

Appendix A, “Example: Outlet Works Locations, Type, and Size,” of this chapter provides additional details for locating, typing, and sizing outlet works. These examples include:

- **Example 1 – New Embankment Dam and New Multipurpose River Outlet Works.** Presents an overview of locating, typing, and sizing a new multipurpose river outlet works associated with a new embankment dam.
- **Example 2 – Existing Concrete Dam and New Multipurpose River Outlet Works.** Presents an overview of locating, typing, and sizing a new multipurpose river outlet works associated with modifying an existing concrete dam.
- **Example 3 – Existing Embankment Dam and Existing River Outlet Works.** Presents an overview of typing and sizing a modified river outlet works associated with modifying an existing embankment dam.

4.6 General Hydraulic Considerations

This section provides general hydraulic considerations for determining the type, location, and size of a modified or a new outlet works. Detailed hydraulic analysis and design can be found in Chapter 5, “Hydraulic Considerations for Spillways and Outlet Works,” of this design standard.

As previously noted, unless highlighted, this chapter is applicable to the evaluation, analysis, and design of reinforced concrete, high velocity, and high flow outlet works.

4.6.1 Discharge Capacity

Discharge capacity is usually presented in the form of drawings (discharge curves) and/or tables with discharges (cubic feet per second) related to RWS elevations (feet). Estimation of discharge capacity is based on either analytical methods or physical models. Analytical methods will typically be used for all levels of design (appraisal, feasibility, and final design levels), while physical models are typically limited to final design levels. Furthermore, physical models are employed for atypical designs involving unusual topography, geometry, and/or discharges and velocities that exceed experience levels.

Key in the estimation of discharge capacity is determining the hydraulic control(s) for the full range of outlet works operation (i.e., full range of RWS that would invoke outlet works releases). Hydraulic controls for most Reclamation outlet works will normally involve pipe control. In some occasions, orifice and/or crest control may come into play. With the exception of canal headworks, typical or normal operations of river, M&I, sluiceway, and power outlet works are almost always associated with sufficient hydraulic head (depth of reservoir above the outlet works entrance) that would result in pipe flow conditions. Because canal headworks tend to be located high in the reservoir, insufficient hydraulic head

Design Standards No. 14: Appurtenant Structures for Dams (Spillways and Outlet Works) Design Standards

(due to reservoir fluctuation) to maintain pipe flow conditions could exist during normal operation. Also, during atypical operations such as drawing down (emptying) the reservoir, insufficient hydraulic head to maintain pipe flow conditions could exist for river, M&I, sluice, and power outlet works. In these cases, orifice and/or crest control conditions could exist. Further details of these hydraulic control conditions include those discussed below.

4.6.1.1 Crest Control (Uncontrolled or Free Flow)

Crest control occurs when there is a free (water) surface and subcritical flow conditions¹¹ exist upstream of the control structure (such as a sill associated with an intake structure), then pass through a critical state (i.e., when the Froude number¹² is equal to unity or when the specific energy¹³ is at a minimum for a given discharge) at or just downstream of the crest or sill to a supercritical flow condition.¹⁴ The governing equation for crest control is the weir equation (see figure 4.6.1.1-1 and table 4.6.1.5-1 for more details).

$$Q = CLH^{\frac{3}{2}} \text{ (weir equation)}$$

Where:

- Q is the total discharge (ft³/s).
- H is the total hydraulic head above the outlet works sill (i.e., RWS elevation (El_{RWS}) minus outlet works sill crest elevation (El_{OW})) (ft).
- C is the coefficient of discharge (initial suggested values include: 2.62 for broad-crested weir, 3.3 for sharp-crested weir, and 3.7 for an ogee crest). The coefficient of discharge is variable, depending on factors such as head (H), crest shape (ogee, sharp-crested weir, broad-crested weir, etc.), control structure entrance (inlet structure, piers, etc.), approach channel depth (P) and geometry, and downstream conditions (suppression, submergence).
- L is the crest length (ft.)

¹¹ Subcritical flow conditions occur when the Froude number is less than unity with low velocity flow described as tranquil and streaming [26].

¹² Froude number is defined as the ratio of inertial forces to gravity forces or average flow velocity (V) divided by the square root of the product of gravity (g) and hydraulic depth (D), which is typically the wetted area (A) divided by the top width (T) of the water surface [26].

¹³ Specific energy is defined as energy per pound of water measured from the channel bottom or the sum of flow depth (d) and velocity head ($V^2/2g$) [26].

¹⁴ Supercritical flow conditions occur when the Froude number is greater than unity with high velocity flow described as rapid, shooting, and torrential [26].

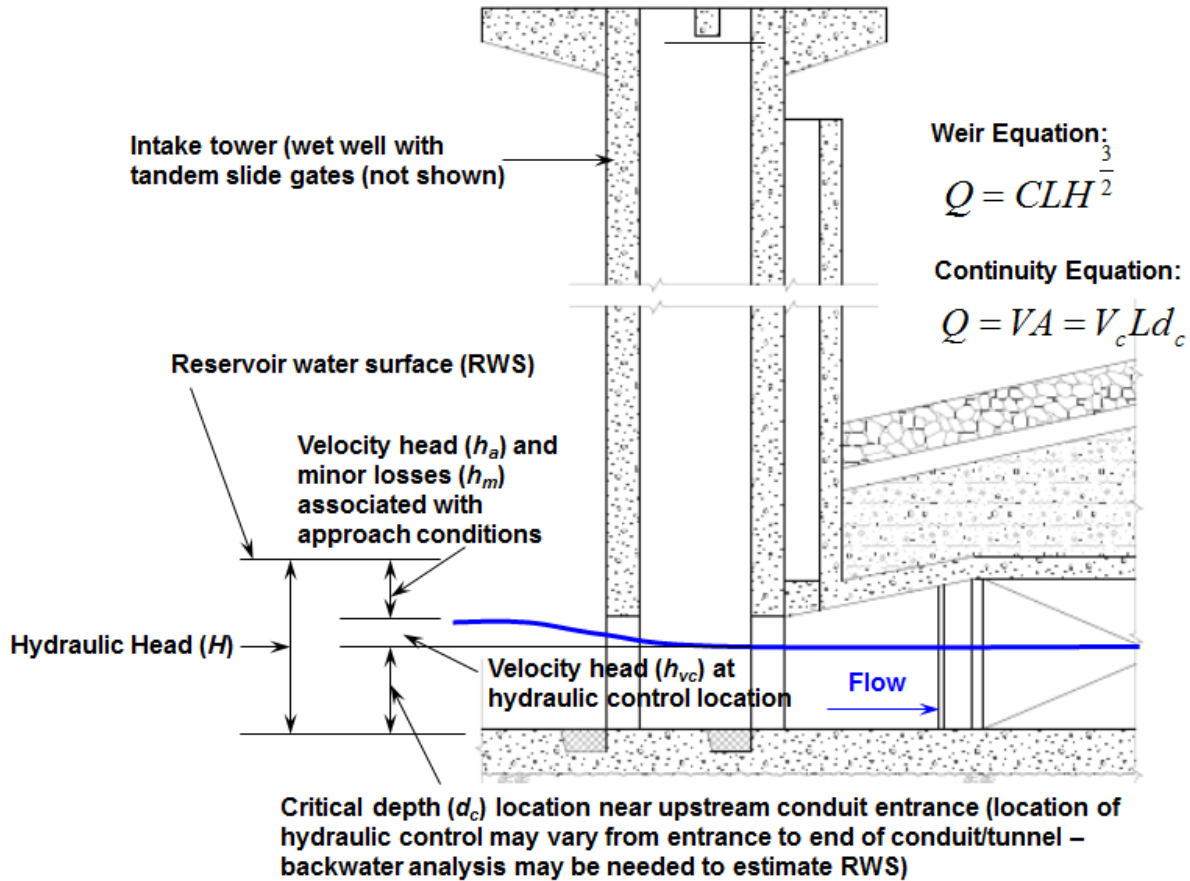

Figure 4.6.1.1-1. Crest control.

4.6.1.2 Orifice Control (Controlled Flow)

A constriction of the wetted area (such as a partially opened gate) between the upstream reservoir and downstream conveyance features (such as a conduit that is free flowing, not pressurized) creates a pressure and velocity change. The governing equation is derived from the Bernoulli¹⁵ and continuity¹⁶ equations (see figure 4.6.1.2-1 and table 4.6.1.5-2 for more details).

¹⁵ Bernoulli or energy equation is based on the total energy or head (H) being equal to the sum of the head above a datum ($z_1 - El_{datum}$), the flow depth (d), and the velocity head ($V^2/2g$). With this in mind, and applying the principle of conservation of energy (continuity), the Bernoulli equation is defined as total head at point 1 ($H_1 = z_1 + d_1 + V_1^2/2g$) equal to the total head at a downstream point 2, plus the loss of head (h_L) between point 1 and point 2 ($H_2 = z_2 + d_2 + V_2^2/2g + h_L$) [26].

¹⁶ Continuity equation is based on the total discharge (Q) being constant throughout and discharge is the product of average velocity (V) and wetted area (A). Given this, the continuity equation is defined as the product of average velocity (V_1) and wetted area (A_1) at point 1 equal to the product of average velocity (V_2) and wetted area (A_2) at point 2 [26].

**Design Standards No. 14: Appurtenant Structures for Dams
(Spillways and Outlet Works) Design Standards**

$$Q = CA\sqrt{2gH_a} \text{ (orifice equation)}$$

- Where:
- Q is the total discharge (ft³/s).
 - H_a is the total hydraulic head above the orifice opening centerline elevation (i.e., RWS elevation (z_{RWS}) minus orifice opening centerline elevation (z_{ORF}) or the downstream tailwater elevation if it exceeds the centerline of the orifice opening (z_{TWS})) (ft).
 - C is the coefficient of discharge (initial suggested value includes: 0.6 for vertical or horizontal wall entrance conditions and 0.9 for bellmouth entrance conditions, which are further detailed in *Design of Small Dams* [5]).
 - A is the area of orifice opening (i.e., product of the opening width (L) and the minimum dimension (d) between the top of the flow surface and the bottom of the opening) (ft²).
 - g is the acceleration due to gravity (ft/s²).

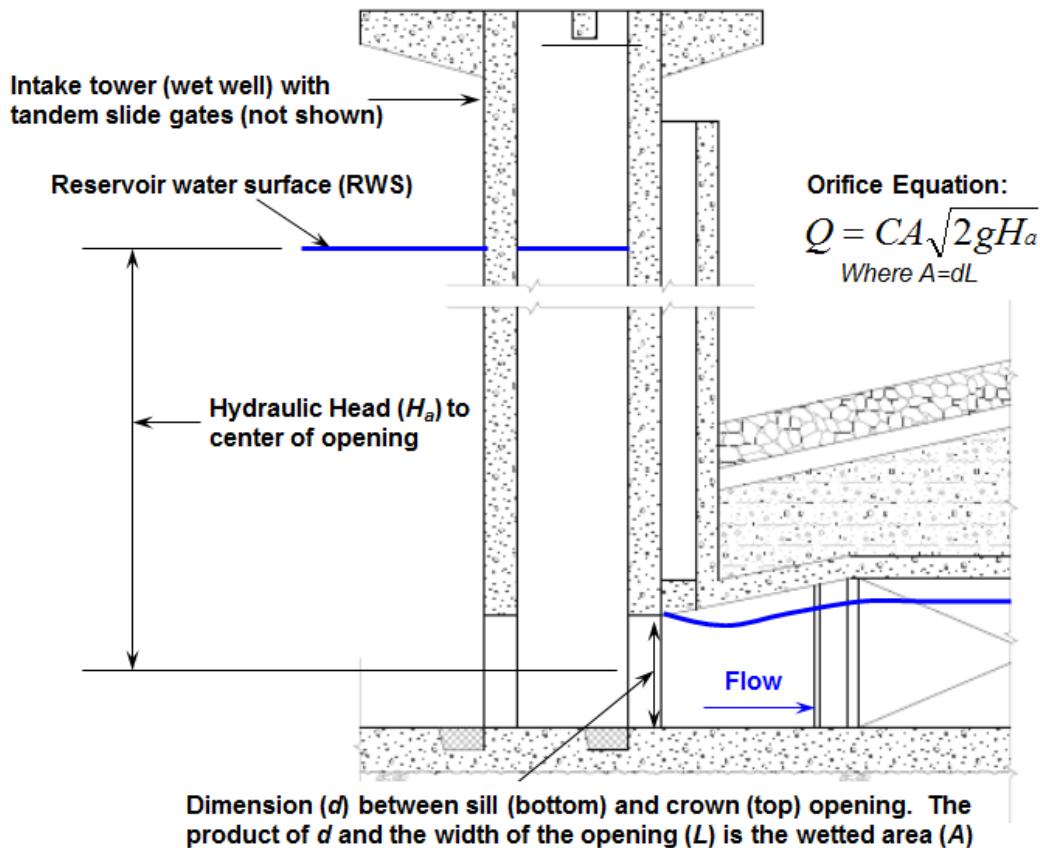

Figure 4.6.1.2-1. Orifice control.

4.6.1.3 Pipe Control (Pressurized Flow)

Pipe control (pressurized flow) exists when the water is being confined in a closed system (such as a conduit or tunnel) between the upstream reservoir and downstream river channel, creating a pressure and velocity change. The governing equation is derived from the Bernoulli and the continuity equations (see figure 4.6.1.3-1 and table 4.6.1.5-3¹⁷ for more details).

$$Q_2 = Q_1 \sqrt{\frac{H_2}{H_1}} \Rightarrow Q_2 = K_P \sqrt{H_2} \text{ (form of Bernoulli equation)}$$

Where:

- Q_1 is the assumed total discharge (ft³/s).
- Q_2 is the calculated total discharge (ft³/s).
- H_1 is associated with Q_1 and is the estimated total head equal to the difference between the RWS and the downstream reference elevation. H_1 is further defined as the sum of the system head losses (h_{L1}) and the exit velocity head (h_{V1}) (ft).
- H_2 is associated with Q_2 and is the estimated total head equal to the difference between the RWS and the downstream reference elevation. H_2 is further defined as the sum of the system head losses (h_{L2}) and the exit velocity head (h_{V2}) (ft).
- K_P is $Q_1/(H_1)^{1/2}$

4.6.1.4 Multiple Hydraulic Controls

The typical hydraulic control condition will be pipe flow over the majority of RWS ranges; however, as previously noted, orifice and/or free-flow conditions may exist for some specific operating conditions and/or limited RWS ranges and should be accounted for when estimating the release capacity of an outlet works. The most common example of a multiple hydraulic control condition for an outlet works will be a crest control discharge curve associated with lower RWSs, and then shifting to pipe control discharge curve for higher RWSs.

¹⁷ Table 4.6.1.5-3 appears later, in Section 4.6.1.5, “Discharge Capacity Design Procedures” in this chapter.

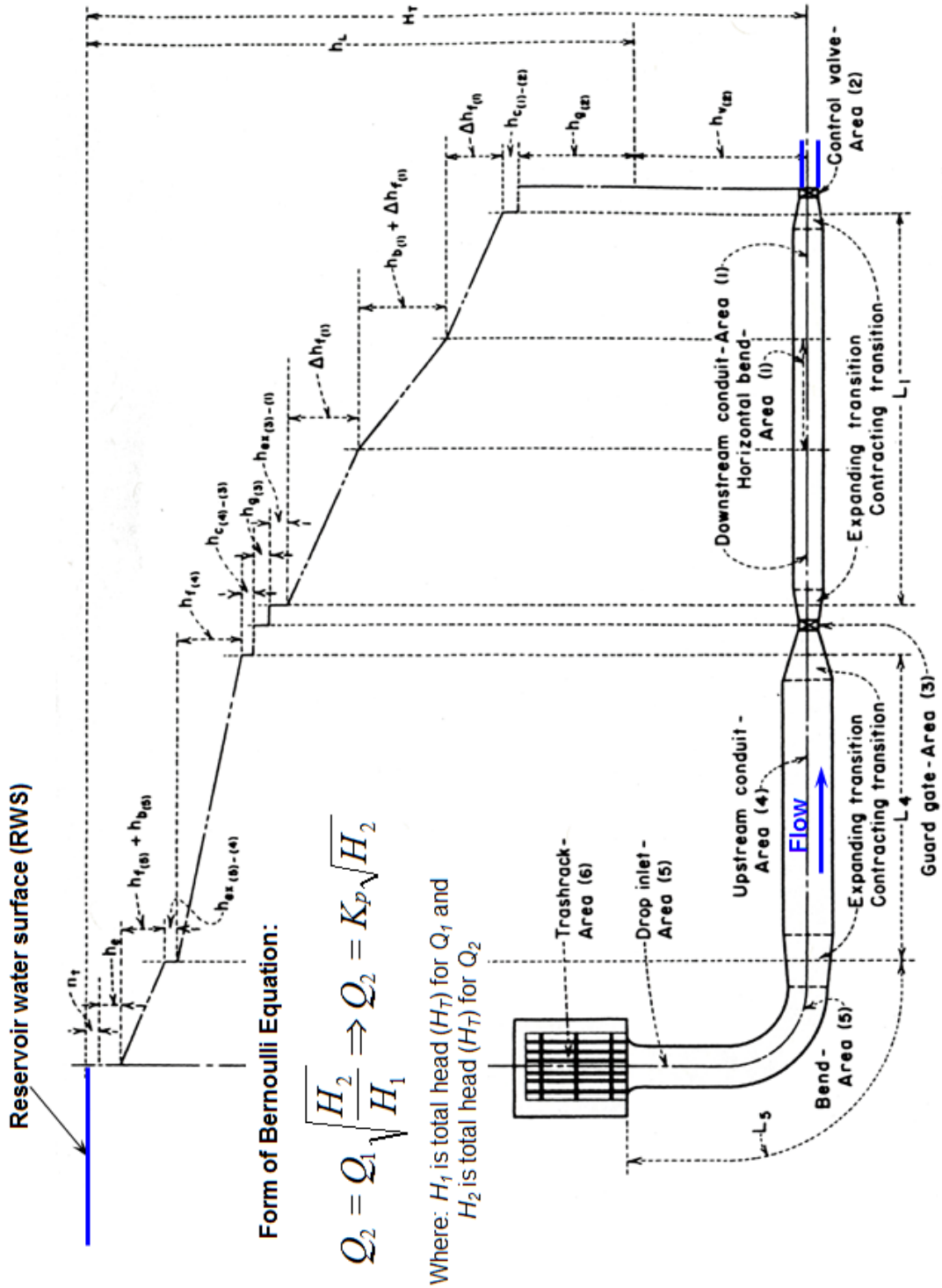

Figure 4.6.1.3-1. Pipe control.

4.6.1.5 Discharge Capacity Design Procedures

When using analytical methods, the general steps for estimating the discharge capacity of an outlet works when the hydraulic control is crest control are summarized in table 4.6.1.5-1.

Similar steps apply for estimating the discharge capacity of an outlet works when the hydraulic control is orifice or pipe control. These steps are summarized in tables 4.6.1.5-2 and 4.6.1.5-3.

As previously noted, more than one hydraulic control will typically come into play during portions of the full range of RWSs that invoke outlet works releases. A composite discharge capacity curve and/or table is developed which combines discharge estimates from tables 4.6.1.5-1, 4.6.1.5-2, and 4.6.1.5-3. Discharge curves illustrating multiple hydraulic controls for fully opened gates or valves (100 percent opened) are presented in figure 4.6.1.5-1. Also, discharge curves illustrating partial gate or valve openings (less than 100 percent opened) are illustrated in the same figure.

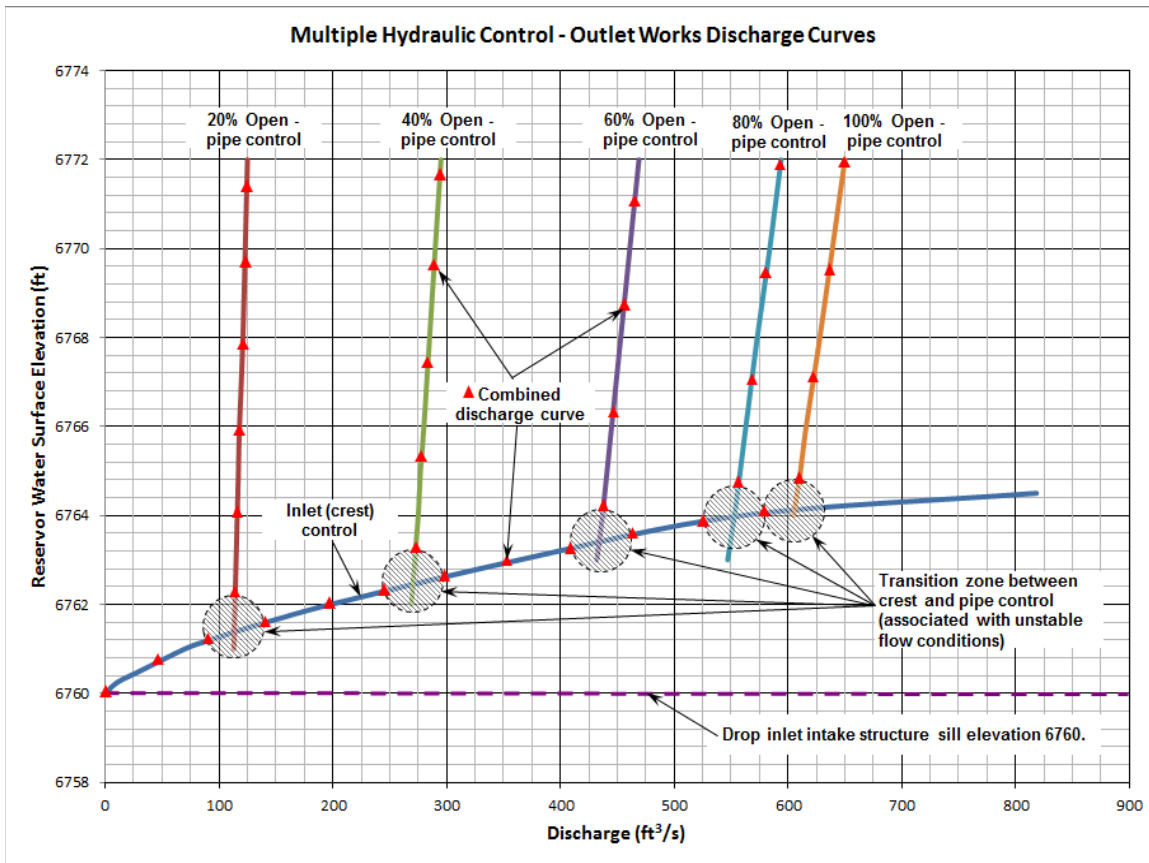

Figure 4.6.1.5-1. Discharge curve - multiple hydraulic controls.

**Design Standards No. 14: Appurtenant Structures for Dams
(Spillways and Outlet Works) Design Standards**

Table 4.6.1.5-1. Procedure for Estimating Discharge Capacity of an Outlet Works for Crest Control Conditions

Step 1 (Initial Assumptions)	Assume a constant coefficient of discharge (C), crest length (L), and crest elevation. Typical assumed (initial) C for a sharp crested weir or bellmouth entrance is 3.30 and 2.62 for a broad crested weir such as a sill.
Step 2 (Initial Discharge Curve)	Compute an initial discharge capacity (curve and/or table), where: $Q = CLH^{\frac{3}{2}}$ (weir equation) Where H is the hydraulic head above the outlet works intake structure sill and/or entrance (i.e., RWS elevation (z_{RWS}) – outlet works intake structure sill and/or entrance elevation (z_{CRT})).
Step 3 (Initial Composite Discharge Curve)	Crest control conditions are typically a small part of an outlet works discharge curve (lower portion of RWS range) and seldom come into play. If crest control is a factor, use step 2 estimates in combination with orifice and/or pipe flow condition estimates to construct a combined discharge curve for the entire range of RWS s (see tables 4.6.1.5-2 and 4.6.1.5-3).
Step 4 (Initial Flood Routings and/or Evacuation)	If the outlet works will pass flood events, route floods (hydrographs) to determine the maximum RWS s (see Section 4.6.2, “Flood Routing,” in this chapter for more details). Also, the outlet works will typically be key in reservoir evacuation and first filling studies, which should be completed at this time (see Section 4.6.3, “Reservoir Evacuation and First Filling,” in this chapter for more details).
Step 5 (Refine Coefficient of Discharge)	If results from step 4 are sensitive (small changes in discharge estimates associated with crest control conditions could appreciably change flood routing and/or reservoir evacuation and first filling results), refine coefficient of discharge (C) by estimating variable C using hydraulic handbooks [27], finite volume analysis (such as FLOW3D), or physical models. Also, additional details can be found in Chapter 5, “Hydraulic Considerations for Spillways and Outlet Works,” of this design standard.
Step 6 (Revise Flood Routings and/or Evacuation)	Re-estimate combined discharge curve (with orifice and/or pipe flow conditions estimates) for the entire range of RWS s (see tables 4.6.1.5-2 and 4.6.1.5-3). Re-route floods and re-evaluate reservoir evacuation and first filling (see Section 4.6.3, “Reservoir Evacuation and First Filling,” in this chapter for more details).

Similar steps for estimating the discharge capacity of an outlet works, where the hydraulic control is orifice or pipe control, applies and are summarized in the following tables:

Chapter 4: General Outlet Works Design Considerations

Table 4.6.1.5-2. Procedure for Estimating Discharge Capacity of an Outlet Works for Orifice Control Conditions

<p>Step 1 (Initial Assumptions)</p>	<p>Assume a constant coefficient of discharge (C), area of orifice opening (A), and centerline elevation of orifice opening. Typical assumed (initial) C for an orifice is 0.60 for vertical or horizontal wall entrance conditions and 0.9 for bellmouth entrance conditions (refined C from step 5 will typically be between 0.60 to 0.98), depending on the application (such as radial or wheel-mounted gate associated with a short tube; vertical or horizontal wall with or without a bellmouth entrance).</p>
<p>Step 2 (Initial Discharge Curve)</p>	<p>Compute an initial discharge capacity (curve and/or table), where:</p> $Q = CA\sqrt{2gH_a} \text{ (orifice equation)}$ <p>Where H_a is the hydraulic head above the orifice opening centerline elevation, i.e., RWS elevation (Z_{RWS}) – orifice opening centerline elevation (Z_{ORF}) or the downstream tailwater elevation if it exceeds the centerline of the orifice opening (Z_{TWS}).</p>
<p>Step 3 (Initial Composite Discharge Curve)</p>	<p>Orifice control conditions are typically a small part of an outlet works discharge curve (lower portion of RWS range) and seldom come into play. If orifice control is a factor, use the estimate in step 2, combined with estimates of crest and/or pipe flow conditions, to construct a combined discharge curve for the entire range of RWS (see tables 4.6.1.5-1 and 4.6.1.5-3).</p>
<p>Step 4 (Initial Flood Routings and/or Evacuation)</p>	<p>If the outlet works will pass flood events, route floods (hydrographs) to determine the maximum RWS (see Section 4.6.2, “Flood Routing,” in this chapter for more details). Also, the outlet works will typically be key in reservoir evacuation and first filling studies, which should be completed at this time (see Section 4.6.3, “Reservoir Evacuation and First Filling,” in this chapter for more details).</p>
<p>Step 5 (Refine Coefficient of Discharge)</p>	<p>If results from step 4 are sensitive (small changes in discharge estimates associated with orifice control conditions could appreciably change flood routing and/or reservoir evacuation and first filling results), refine coefficient of discharge (C) by estimating variable C using hydraulic handbooks [27], procedures for estimating discharge coefficients for short tubes found in <i>Design of Small Dams</i> [5], finite volume analysis (such as FLOW3D), or physical models. Also, additional details can be found in Chapter 5, “Hydraulic Considerations for Spillways and Outlet Works,” of this design standard.</p>
<p>Step 6 (Revise Flood Routings and/or Evacuation)</p>	<p>Re-estimate combined discharge curve (with crest and/or pipe flow conditions estimates) for the entire range of RWS (see tables 4.6.1.5-1 and 4.6.1.5-3). Re-route floods and re-evaluate reservoir evacuation and first filling studies (see Section 4.6.3, “Reservoir Evacuation and First Filling,” in this chapter for more details).</p>

**Design Standards No. 14: Appurtenant Structures for Dams
(Spillways and Outlet Works) Design Standards**

Table 4.6.1.5-3. Procedure for Estimating Discharge Capacity of an Outlet Works for Pipe Control Conditions

<p>Step 1 (Initial Assumptions)</p>	<p>Assume pressure flow conditions and estimate head losses (h_L) between the reservoir and downstream river channel for an assumed discharge (Q_1). Additional details about typical head losses can be found in <i>Design of Small Dams</i> [5] and Chapter 5, “Hydraulic Considerations for Spillways and Outlet Works” of this design standard.</p>
<p>Step 2 (Initial Discharge Curve)</p>	<p>Compute total head (H_1) for assumed discharge (Q_1) and controls (gates/valves) are fully opened, where:</p> $H_1 = h_{V1} + \sum h_{L1}$ <p>Compute an initial discharge capacity (curve and/or table), where:</p> $Q_2 = Q_1 \sqrt{\frac{H_2}{H_1}} \text{ (form of Bernoulli equation)}$ <p>Where H_2 is the total head between assumed RWS elevations (z_{RWS}) and downstream reference elevations (z_{DS}).</p> <p>Notes: General guidance for downstream reference elevation (E_{DS}) includes:</p> <ul style="list-style-type: none"> • For unsupported flow (free-flow conditions), use centerline elevation of downstream exit. • For support flow where tailwater is at or below centerline elevation of downstream exit, use crown (top) elevation of downstream exit. • For support flow where tailwater is between centerline and top of downstream exit, use crown (top) elevation of downstream exit. • Where tailwater exceeds downstream crown (top) elevation of exit, use tailwater surface elevation. <p>z_{DS} could vary with discharge, so some iteration may be needed to estimate the discharge (Q_2) for a given total head (H_2) (i.e., tailwater surface for 500 ft³/s versus 1,000 ft³/s could be very different). Also, a key factor in estimating the discharge capacity of pressure flow conditions is estimating the head losses (h_L).</p>
<p>Step 3 (Initial Composite Discharge Curve)</p>	<p>Since pipe control conditions are typically the majority of an outlet works discharge curve (applies to most of the RWS range) and will come into play on a regular basis, care must be taken in developing the step 2 estimate, which is in combination with crest and/or pipe flow conditions estimates, to construct a combined discharge curve for the entire range of RWS (see tables 4.6.1.5-1 and 4.6.1.5-3).</p>
<p>Step 4 (Initial Flood Routings and/or Evacuation)</p>	<p>If the outlet works will pass flood events, route floods (hydrographs) to determine the maximum RWS (see Section 4.6.2, “Flood Routing,” in this chapter for more details). Also, the outlet works will typically be key in reservoir evacuation and first filling studies, which should be completed at this time (see Section 4.6.3, “Reservoir Evacuation and First Filling,” in this chapter for more details).</p>

Table 4.6.1.5-3. Procedure for Estimating Discharge Capacity of an Outlet Works for Pipe Control Conditions

<p>Step 5 (Refine Coefficient of Discharge)</p>	<p>If results from step 4 are sensitive (small changes in discharge estimates associated with pipe control conditions could appreciably change flood routing and/or reservoir evacuation and first filling results), refine total head estimates (H_1) by employing finite volume analysis (such as FLOW3D) or physical models. Also, additional details can be found in Chapter 5, “Hydraulic Considerations for Spillways and Outlet Works,” of this design standard.</p>
<p>Step 6 (Revise Flood Routings and/or Evacuation)</p>	<p>Re-estimate combined discharge curve (with crest and/or orifice flow conditions estimates) for the entire range of RWS (see tables 4.6.1.5-1 and 4.6.1.5-2). Re-route floods and re-evaluate reservoir evacuation and first filling studies (see Section 4.6.3, “Reservoir Evacuation and First Filling,” in this chapter for more details).</p>

4.6.1.6 Existing Outlet Works

For existing outlet works that are part of Reclamation’s inventory of dams, discharge capacities have been determined and are typically well defined. The primary source for current (official) outlet works discharge capacities information is the SOP for a given dam. The discharge capacities found in the SOP represent existing operating conditions and will typically provide adequate information unless operational and/or physical changes are being considered, such as raising the normal or flood-induced maximum RWS, or modifying or replacing features of the existing outlet works. In these cases, the existing discharge capacity should be re-evaluated and (if needed) re-estimated. Another source for existing outlet works discharge capacities are physical (hydraulic) model study reports, which are available for many Reclamation facilities. Also, actual flow measurements from river gages, flowmeters, or other measuring devices can be used to verify existing discharge curves or to develop discharge curves. General analytical procedures for evaluating and estimating the discharge capacity have been previously noted. Finally, details on reevaluating and re-estimating the discharge capacity are further addressed in Chapter 5, “Hydraulic Considerations for Spillways and Outlet Works,” of this design standard.

For existing outlet works that are not part of Reclamation’s inventory, discharge capacity information may not always be available. If this is the case, estimates will be developed using either analytical methods or physical models. General procedures for evaluating and estimating the discharge capacity have been previously noted. Details on evaluating and estimating the discharge capacity are further addressed in Chapter 5, “Hydraulic Considerations for Spillways and Outlet Works,” of this design standard.

4.6.1.7 New Outlet Works

For new outlet works, discharge capacity estimates will be developed using either analytical methods or physical models. The hydraulic control(s) for the new outlet works is first determined, and then discharge capacities are estimated.

Design Standards No. 14: Appurtenant Structures for Dams (Spillways and Outlet Works) Design Standards

General procedures for evaluating and estimating the discharge capacity are previously noted. Details on evaluating and estimating the discharge capacity are further addressed in Chapter 5, “Hydraulic Considerations for Spillways and Outlet Works” of this design standard.

4.6.2 Flood Routing

Flood routing involving outlet works will only apply to those situations where the outlet works will be used during floods, typically in combination with other hydraulic structures such as spillways. Reservoir flood routings are typically based on one-dimensional level pool conditions (sometimes referred to as static flood routings), where the change in reservoir storage is the difference between inflow and outflow during a given time interval. Key considerations for preparing a flood routing are discussed below.

4.6.2.1 Current Data

For an existing dam, the source for current data is usually the SOP. However, data may need to be collected, created, and/or extended if current data are not available. For a new dam, data will be collected and/or developed. These data include:

- **Reservoir storage (acre-feet) versus reservoir elevation (feet)** portrayed as a curve or in tabular form. If reservoir storage data and/or existing topography are not sufficient, an acceptable method of extending (extrapolating) reservoir storage is by assuming a linear (straight-line) extension of the reservoir surface area curve to higher elevations. The incremental reservoir storage can be estimated by using the prismoidal equation¹⁸ for a given depth bounded by two RWS and the reservoir surface areas associated with these RWS. For existing reservoirs, sediment accumulation may affect available reservoir storage that, in turn, could affect flood routing results.
- **Reservoir operations**, which could influence when and how hydraulic structures releases are made.

¹⁸ Prismoidal equation - $\Delta VOL = (\Delta H/6) \times (A_1 + A_2 + 4 \times A_M)$, where: ΔVOL is incremental storage (acre-feet); ΔH is depth between two RWS elevations (feet); A_1 and A_2 are the reservoir surface areas which bound the incremental depth (acres); and A_M is the reservoir surface area associated with the midpoint RWS within the incremental depth (acres). **Note:** The average end area method for estimating volume, $\Delta VOL = (\Delta H/2) \times (A_1 + A_2)$, should only be used when a prismoid varies in only one direction (like a wedge). If the prismoid varies in two or three directions (such as a pyramid), the average end area method will either underestimate or overestimate the correct volume and should not be used (an example of this is a truncated pyramid shape or frustum that defines splitter walls in a segmented fuseplug spillway control structure – the walls slope in two directions).

- **Discharge capacity for each appurtenant structure** (including dam crest for overtopping conditions), which will be involved in routing the hydrograph (see Section 4.6.1, “Discharge Capacity,” in this chapter for more details).

4.6.2.2 Starting RWS

The starting RWS elevation is perhaps the most sensitive variable that can be adjusted in a flood routing. General guidelines include:

- **For reservoirs without flood control** (refer to the SOP for any specific requirements for an existing dam). If not noted in the SOP for an existing dam or if dealing with a new dam, the maximum starting RWS will usually be the maximum normal conditions, typically the top of active conservation. Please note that although the maximum normal RWS is typically assumed for design purposes, a range of starting RWS will need to be evaluated when dealing with quantitative risk analysis.
- **For reservoirs with flood control** (again, refer to the SOP for any specific requirements for an existing dam). If not noted in the SOP for an existing dam or if dealing with a new dam, the maximum flood control reservation RWS (RWS typically less than the maximum normal conditions, which provides additional flood storage space in the reservoir) will be used as a minimum, and the maximum normal conditions (the top of active conservation and/or top of joint use) will be used as a maximum. As previously noted, a range of starting RWS will need to be evaluated for quantitative risk analysis.

4.6.2.3 Starting Time

The starting time for routing a hydrograph can change the resulting maximum RWS and the appurtenant structures discharge. General guidelines are summarized in the following bullets:

- **For reservoirs without flood control and hydrographs without antecedent flood conditions** (i.e., inflow is greater than base flow conditions). The starting RWS is maintained until inflow exceeds the discharge capacity of the appurtenant structures (typically referred to as “outflow equals inflow”).
- **For reservoirs without flood control and hydrographs with antecedent flood conditions.** The starting time is usually set at the beginning of the flood event (typically referred to as “time equals zero”).
- **For reservoirs with flood control and hydrographs with or without antecedent flood conditions.** Outflow is restricted to conform with flood damage reduction requirements up to a specified RWS or a range of RWS (i.e., rule curves), above which there are typically no discharge restrictions.

Design Standards No. 14: Appurtenant Structures for Dams (Spillways and Outlet Works) Design Standards

4.6.2.4 Time Increments

To ensure that the maximum RWS elevation and/or maximum appurtenant structure discharges are determined, use 1-hour (or smaller) time increments before and after the maximum RWS is reached (Note: This may require multiple routings to identify the timeframe when the maximum RWS occurs, then refining time increments during this timeframe, possibly in the range of 3 to 6 hours before and after the maximum RWS occurs). Time increments as small as 15 minutes may be needed for short duration hydrographs such as a thunderstorm event. The intent is to determine when outflow equals inflow at the maximum RWS, and when outflow exceeds inflow as the reservoir is drawn down.

4.6.2.5 Complete Routings

All flood routings should be run until the RWS elevation recedes to the starting RWS or has reached a steady-state condition (i.e., does not continue to recede due to outflow equals inflow). This can provide durations for the outlet works and other hydraulic structure operation and/or dam overtopping, which is used for assessment purposes (such as evaluating adverse hydraulic potential and/or identifying flow surface tolerances). It should be highlighted for hydrographs with multiple peaks, ensure the routings extend past the last peak.

4.6.2.6 Robustness (Freeboard) Study

As discussed in Chapter 2, “Hydrologic Considerations,” of this design standard, uncertainties are evaluated and addressed by a robustness study. These uncertainties may be related to the method of estimating floods, reservoir and dam operations, gated spillway or outlet works misoperations, reduction of spillway or outlet works discharge capacity due to debris and other mechanisms, and future events associated with upstream and downstream developments. To account for these uncertainties, plausible “what-if” scenarios are evaluated by simulating the what-if conditions in the flood routings. These scenarios could create elevated maximum RWS above the design maximum RWS, which will be used to establish freeboard requirements for either an existing or a new dam. See Chapter 2, “Hydrologic Considerations,” of this design standard for the robustness (freeboard) study details and examples.

4.6.3 Reservoir Evacuation and First Filling

Important considerations for storage and multipurpose dams include the ability to evacuate (lower or drain) the reservoir in a timely manner and control first filling rates of a reservoir. For the most part, the key hydraulic structure used to lower the reservoir in a timely manner or control the rise of the reservoir is the outlet works; however, all hydraulic structures, including the outlet works, gated spillways, and power penstocks, could be employed to control the reservoir [28].

It should be highlighted that a reservoir evacuation study is typically associated with an emergency situation. Generally speaking, an emergency situation could initiate rapid lowering of the reservoir.¹⁹ Care must be exercised with the rate of lowering the reservoir due to potential damage or failure of an appurtenant structure (adverse hydraulics), dam (slope failure), or reservoir rim (landslide).

Because it is important to fully understand the dam facilities' ability to evacuate the reservoir and control first filling, appropriate documentation should be available in Reclamation's inventory for all existing storage and multipurpose dams. Additionally, an evaluation and documentation should be prepared as part of any design to modify existing dams or construct new dams. First filling guidelines should be completed before initial filling of the reservoir begins. Typically, they are issued as a separate document and may also be included in the Designers' Operating Criteria (DOC) and SOP. See Appendix C, "First Filling Guidelines," for more details.

Reservoir evacuation and first filling studies use similar steps as previously noted for flood routing. The following sections summarize key considerations for preparing reservoir evacuation and/or first filling studies.

4.6.3.1 Current Data

For an existing dam, the best source for current data is usually the SOP; however, data may need to be collected, created, and/or extended if current data are not available. For a new dam, data will be collected and/or developed. These data include:

- **Reservoir storage (acre-feet) versus reservoir elevation (feet)** portrayed as a curve or in tabular form.
- **Reservoir operations**, which could influence when and how hydraulic structures releases are made.
- **Discharge capacity for each appurtenant structure**, which will be involved in evacuation and/or first filling operations (see Section 4.6.1, "Discharge Capacity," in this chapter for more details). All waterway release facilities should be considered available for evacuation to the extent that their reliability in an emergency situation can be reasonably certain. For example, the use of canal outlet works and powerplants for evacuation may be limited; (see Assistance Commissioner - Engineering and Research (ACER) Technical Memorandum No. 3 [28]).

¹⁹ As an example, in 1967, a potential internal erosion failure of Reclamation's Fontenelle Dam (embankment) was averted by the rapid lowering (evacuation) of the reservoir by the outlet works.

**Design Standards No. 14: Appurtenant Structures for Dams
(Spillways and Outlet Works) Design Standards**

4.6.3.2 Starting RWS

For reservoir evacuation studies, as with flood routings, the starting RWS elevation is perhaps the most sensitive variable. One of the following three RWS elevations should be selected to determine reservoir evacuation requirements:

- **Top of joint use capacity.** If a reservoir has a flood control requirement, a RWS associated with the top of joint use capacity may have been established and would be considered the maximum normal condition.
- **Top of active conservation capacity.** If a reservoir does not have a flood control requirement (joint use storage or exclusive flood control), the RWS associated with the top of active conservation capacity would be considered the maximum normal condition.
- **Other RWS elevations.** Some RWS other than the top of joint use capacity or the top of active conservation capacity can be considered if current reservoir operations (for an existing dam) or planned reservoir operations (for a new dam) indicate that another RWS is more appropriate. Several examples include the following:
 - An existing reservoir has never filled over an extended period of time. In this case, the historical maximum RWS or higher may be an appropriate starting RWS. Since seepage, which might lead to internal erosion, may not be observed until first filling occurs (i.e., exceeding historical maximum RWS), there may be an elevated risk of failure potential as the reservoir reaches and exceeds the historical maximum RWS. It is at this time that reservoir evacuation capabilities may be critical.
 - For an existing or new dam that is intended to store most of a flood event with limited or no releases during the flood event, the RWS associated with part or all of the exclusive flood control or flood surcharge may be an appropriate starting RWS.

For first filling studies, the starting RWS will vary, depending on the site-specific conditions. Some of the considerations will include:

- **Existing dams.** First filling conditions will exist for RWSs that exceed the maximum historical RWS. Filling rates will be unique for a given dam and may vary from lower to upper reservoir elevation ranges. A normal or common rate might be 1 foot per day (ft/d), with ranges of less than 1 to 3 ft/d for embankment dams. A normal or common rate of 10 ft/d is not excessive for concrete dams on competent rock foundations. Also, intermediate “holds” on (or stoppage of) reservoir filling may be incorporated into the first filling requirements. These “holds” provide

time windows to monitor dam conditions and, if needed, revise filling rates. In particular, ample time must be provided to issue, and for the public to heed, warnings in the event that problems develop. See Appendix C, “First Filling Guidelines,” for more details.

- **New and modified dams.** First filling conditions will be established prior to completing construction. As noted for existing dams, filling rates will be unique for a given dam and may vary from lower to upper reservoir elevation ranges. The filling rates for new or modified dams would be similar to the rates for existing dams, along with appropriate “holds.” See Appendix C for more details.

4.6.3.3 Hydrology

Reservoir inflows for the period of evacuation or first filling are based on streamflow records for the reservoir (existing) or for a given dam site (new).

- **Reservoir evacuation.** Before a reservoir evacuation study can take place, the baseflow must be defined. The inflow will be the largest consecutive mean monthly streamflows for the reservoir evacuation period. The following steps are followed when estimating base flows and conducting evacuation studies:
 - Obtain mean monthly inflows (ft^3/s) for the site. Sources for mean monthly inflows include the U.S. Geological Survey’s (USGS) Surface-Water Data for the Nation and historic reservoir operations data.
 - Make an initial estimate of the required evacuation period based on reservoir storage to be evacuated and the discharge capacity of the waterways. An initial estimate of 3 to 4 months is typical.
 - Develop an inflow hydrograph of the highest consecutive mean monthly inflows, which is equal to the estimated time of the evacuation made in the previous bullet.
 - Select an initial RWS and perform an evacuation flood routing to determine the evacuation time.
 - Compare the computed evacuation time (from the evacuation flood routing) to the estimated duration of the inflow hydrograph.
 - If the computed evacuation time is greater than the estimated inflow hydrograph, add 1 additional month to the hydrograph and rerun the evacuation flood routing. Continue this process until the computed evacuation time is within the estimated inflow hydrograph.

**Design Standards No. 14: Appurtenant Structures for Dams
(Spillways and Outlet Works) Design Standards**

- After the evacuation time for the selected initial RWS has been determined, a parametric assessment can be made to determine how sensitive the evacuation time versus RWS elevation is for extended inflow hydrographs. This assessment is done by varying the initial RWS and varying the starting month of the hydrograph. Earlier starting months will require adding 1 month of average inflows at the beginning of the hydrograph. Later starting months may require adding 1 month of average inflows at the end of the hydrograph. If similar evacuation times for associated RWSs are achieved, no further action is needed; however, if there are significant increases in the evacuation time required to reach target RWSs, further evaluation may be warranted to assess what impacts (if any) may result from the increased evacuation times.

- Example:
 - Initial evacuation time estimated to be 4 months based on dividing the storage (acre-feet) to be evacuated by the average discharge capacity (ft^3/s) associated with the hydraulic head that bounds the storage to be evacuated and adding 1 month to account for inflows.

 - The inflow hydrograph for the initial estimated 4-month period (using the highest consecutive mean monthly inflows) is based on February, March, April, and May, with mean monthly inflows of $5,400 \text{ ft}^3/\text{s}$, $7,100 \text{ ft}^3/\text{s}$, $8,900 \text{ ft}^3/\text{s}$, and $6,900 \text{ ft}^3/\text{s}$, respectively. The hydrograph would be defined as $5,400 \text{ ft}^3/\text{s}$ during the first 28 days, $7,100 \text{ ft}^3/\text{s}$ during the next 31 days, $8,900 \text{ ft}^3/\text{s}$ during the next 30 days, and $6,900 \text{ ft}^3/\text{s}$ during the final 31 days.

 - Evacuation flood routing results indicate that it will require more than 4 months to evacuate the reservoir using the estimated inflow hydrograph and the selected initial RWS.

 - Inflow hydrograph expanded to 5 months by including the June mean monthly inflow of $5,100 \text{ ft}^3/\text{s}$ over 30 additional days and new routings performed. The mean monthly inflow for June was greater than the mean monthly inflow for January. New evacuation routings indicate evacuation times do not exceed 5 months.

- Parametric routings show that evacuation times for starting the hydrograph at the beginning of January or at the beginning of March do not exceed evacuation times for starting the evacuation at the beginning of February. Additional parametric routings using different initial RWS elevations also show minimal effect in evacuation times.
- **First filling.** The inflow will be the combination of base flow (mean monthly streamflows for the anticipated filling period – see “Reservoir Evacuation” bullet, above, for details) and a frequency flood. The frequency flood will be selected so that total risks during first filling are at acceptable levels. The process for selecting the frequency flood for first filling is very similar to the process for selecting construction diversion floods. For more information, see Chapter 2, “Hydrologic Considerations,” of this design standard. If there are no risk considerations, the minimum frequency flood can be based on five times the length of the filling period with a minimum return period of 5 years. As an example, a large reservoir requiring 5 years to fill might require outlet works sized to pass the 25-year flood, in addition to the mean inflow.

4.6.3.4 Reservoir Evacuation Risk and Hazard Classifications

Acceptable reservoir evacuation guidelines are based on the site-specific level of risk and downstream hazard potential. It should be highlighted that risk associated with reservoir evacuation relies on previous risk analyses (possibly updated) for existing high hazard dams and current risk analyses for new high hazard dams. High risk would be associated with Reclamation’s Public Protection Guidelines threshold values for increasing justification to take action to reduce or better define risk [29]. In almost all cases, this would be a temporary condition because Reclamation would take action to reduce risk to below the threshold levels. Significant risk would be associated with risks which were below but near the Public Protection Guideline threshold values. These risks may or may not be temporary, depending on the dam safety decisions that were made. Low risk would be associated with risks that were well below (at least an order of magnitude below) the Public Protection Guideline threshold values [29]. For a high hazard dam, an overall risk analysis should be prepared or updated in accordance with Section 4.3.2.2, “Procedure,” of this chapter.

Risk is evaluated in more general terms for significant and low hazard dams. In these cases, risk is a general subjective representation of the likelihood of the occurrence of adverse events. Table 4.6.3.4-1 provides considerations to assist in estimating the risk as low, significant, or high for significant and low hazard dams.

Defining significant risk is subjective without the benefit of a risk analysis. The factors in table 4.6.3.4-1 should be considered, and if there are not compelling factors in either the higher risk or lower risk set of factors, a significant risk categorization may be appropriate.

**Design Standards No. 14: Appurtenant Structures for Dams
(Spillways and Outlet Works) Design Standards**

Table 4.6.3.4-1. Reservoir Evacuation Risk Considerations for Significant and Low Hazard Dams

Hydrologic Factors	
<p>Higher Risk Factors</p> <ul style="list-style-type: none"> • High possibility of hurricanes or flash floods • Gated spillway • High ratio of flood to storage volumes in the reservoir 	<p>Lower Risk Factors</p> <ul style="list-style-type: none"> • Uncontrolled spillway • Low ratio of flood to storage volumes in the reservoir
Geologic/Geotechnical Factors	
<p>Higher Risk Factors</p> <ul style="list-style-type: none"> • High seismicity at site • Active faults in or near a dam foundation • Possibility of foundation displacement during a major earthquake • High potential for rock solutioning • High potential for foundation liquefaction • High potential for internal erosion 	<p>Lower Risk Factors</p> <ul style="list-style-type: none"> • Low seismicity at site • No active faults in or near dam foundation • Massive competent rock foundation • Good defensive design measures against internal erosion.
Structural Factors	
<p>Higher Risk Factors</p> <ul style="list-style-type: none"> • Severe deterioration of structural members 	<p>Lower Risk Factors</p> <ul style="list-style-type: none"> • Concrete structures in good condition
Operating Factors	
<p>Higher Risk Factors</p> <ul style="list-style-type: none"> • Remote site and dam visited infrequently 	<p>Lower Risk Factors</p> <ul style="list-style-type: none"> • Well trained and experienced operating personnel • Reliable backup power

The downstream hazard classifications of low, significant, and high are based on the probable loss of human life and the impacts on economic, environmental, and lifeline consequences²⁰ in the event of a dam failure and uncontrolled release of the reservoir. The downstream hazard classification levels build on each other (i.e., the higher order classification levels add to the list of consequences for the lower classification levels) [30]. For more details about the downstream hazard classifications, see Chapter 2, “Hydrologic Considerations,” of this design standard.

²⁰ Lifeline consequences include loss of communication and power, water and sewer services, and food supply.

4.6.3.5 Reservoir Evacuation Rates

In general, for storage and/or multipurpose dams, release capabilities should be sufficient to draw down the reservoir, within a period of 1 to 4 months, to the lower of the following levels:

- A RWS commensurate with a storage capacity (acre-feet) that is 10 percent of the reservoir storage capacity at the start of the evacuation
- A RWS which is less than 50 percent of the hydraulic height²¹ of the dam

In addition to these general guidelines, site-specific guidelines should be evaluated and are summarized in table 4.6.3.5-1. These site-specific guidelines determine emergency evacuation time (in days) associated with a given evacuation stage (reservoir depth or volume) and levels of risk and downstream hazard. These guidelines are based on Reclamation’s experience, which reflects a reasonable balance between risks, hazards, and costs. The guidelines are considered conservative and may be adjusted to take into account site-specific conditions. Although it is desirable for a reservoir to meet the evacuation time requirements for all four stages noted in table 4.6.3.5-1, intake elevations of release facilities (such as the sill elevation of a river outlet works) may limit evacuation to RWS levels above some stage elevations. Consequently, the values provided for the various stages should be used only when it is physically possible to lower the reservoir to the associated elevations.

Table 4.6.3.5-1. Reservoir Evacuation Guidelines for Storage and/or Multipurpose Dams, Days

Evacuation Stage	High Hazard, High Risk	High Hazard, Significant Risk	High Hazard, Low Risk	Significant Hazard, High Risk	Significant Hazard, Significant Risk	Significant Hazard, Low Risk	Low Hazard, High Risk	Low Hazard, Significant Risk	Low Hazard, Low Risk
75% height ¹	10-20	20-30	30-40	20-30	30-40	40-50	40-50	50-60	60-90
50% height ¹	30-40	40-50	50-60	40-50	50-60	60-70	60-70	70-90	90-120
10% storage ²	40-50	50-60	60-70	50-60	60-70	70-80	70-80	80-120	120-160
25% height ¹	60-80	70-90	80-100	70-90	80-100	90-110	90-110	100-160	150-220

¹ Height is hydraulic height, which is always measured from the streambed to the maximum controllable RWS (typically, top of active conservation or top of joint use).

² Reservoir storage between the top of dead storage and the initial (normal) RWS. This note is intended to resolve a conflict found in Assistant Commissioner – Engineering and Research (ACER) Technical Memorandum No. 3, “Criteria and Guidelines for Evacuating Storage Reservoirs and Sizing Low-Level Outlet Works” [28], which indicates dead storage should not be considered (table 1 in reference) and also indicates storage between the original streambed and the initial RWS should be used (table 4 in the reference).

²¹ Hydraulic height is defined as the difference between the lowest point in the original streambed at the dam axis or centerline and the maximum controllable RWS (typically top of joint use or top of active conservation).

4.6.3.6 Deviation from Reservoir Evacuation and First Filling Guidelines

The previously noted guidelines should apply to the majority of storage and multipurpose dams; however, it may be impractical to provide sufficient release capacity to meet the guidelines for reservoir evacuation and/or first filling. As an example, some reservoirs may be too large (volume) with small release capacity to meet reservoir evacuation guidelines. Another example might be a very small reservoir where the release capacity is insufficient to limit RWS rise during first filling. For either an existing dam or new dam, if the evacuation guideline timeframes or first filling criteria cannot be met, appropriate documentation should be prepared.

When evaluating evacuation capacity at a high hazard dam using the guidelines outlined in table 4.6.3.5-1, consideration should also be given to the dominant PFMs for the dam being considered. If the dominant PFMs are slow developing PFMs (such as Internal Erosion PFMs, in which the embankment or foundation materials being eroded are somewhat erosion resistant), lowering the reservoir may be very influential in preventing this type of PFM from fully developing. If the dominant PFMs are likely to develop rapidly (such as a PFM related to liquefaction of foundation materials, leading to significant lowering of the dam crest and overtopping of the lowered crest, resulting in a breach of the dam), evacuation capability may have little impact on the ability to slow down or stop the progression of the PFM. Consideration of the site-specific risks can provide additional justification to either pursue improvement of evacuation capability or to not take additional action.

- **For new dams.** Either a technical memorandum (TM) or decision memorandum (DM) should document the following:
 - The rate of RWS rise during first filling period using the maximum discharge capacity of the proposed hydraulic structures (outlet works, spillways, power penstocks, etc.), which will be used to control the reservoir.
 - The evacuation period resulting from using the maximum drawdown capabilities of the proposed hydraulic structures, which will be used to lower the reservoir.
 - Reservoir levels and corresponding storage volume at the end of the reservoir evacuation stages specified by table 4.6.3.5-1.

- Estimates of the size and cost of the outlet works and other hydraulic structures needed to meet the guidelines. If the cost cannot be justified, alternative operational plans or other actions may need to be considered.
- **For existing dams.** Either a TM or DM should document the following:
 - Reliability and present conditions of the dam and hydraulic structures, plus any other items that may limit evacuation such as: (1) the condition of the reservoir relative to the slope stability of the reservoir rim, (2) the stability of accumulated silt around an intake structure during rapid drawdown, and (3) any release restrictions in the downstream channel.
 - If first filling has not occurred, the rate of RWS rise during first filling period using the maximum discharge capacity of the existing hydraulic structures (outlet works, spillways, power penstocks, etc.), which will be used to control the reservoir.
 - The evacuation period resulting from using the maximum drawdown capabilities of the existing hydraulic structures, which will be used to lower the reservoir.
 - Reservoir levels and corresponding storage volume at the end of the reservoir evacuation periods specified by the guidelines.

Estimate the modifications (size and cost) of the outlet works and other hydraulic structures needed to meet the guidelines. Unless modifications can be accomplished at relatively little expense, existing structures will typically not be modified for the sole purpose of meeting reservoir evacuation and/or first filling guidelines; however, when future modifications are proposed to the dam and/or hydraulic structures with inadequate release capacities, the design shall consider increased release capacities to the extent that it can be achieved at a reasonable incremental cost increase.

4.6.4 Other Hydraulics

The previous sections are focused on estimating the discharge capacity of an outlet works. To further define, evaluate, and design outlet works, additional hydraulic considerations come into play. These additional hydraulic considerations are grouped to specific features of the outlet works, such as intake structures, conveyance features, control structures, and terminal structures.

**Design Standards No. 14: Appurtenant Structures for Dams
(Spillways and Outlet Works) Design Standards**

4.6.4.1 Intake Structures Hydraulics

Intake structures are located within the reservoir at a level that will result in sufficient hydraulic head to meet discharge requirements, as well as meeting any water quality and temperature requirements. As previously noted in Section 4.5.2.2.2, “Intake Structure,” of this chapter, there are different types of intake structures, but there are some common hydraulic considerations that apply to most of them, which deal with flow passing from the reservoir and through the intake structure. These considerations are discussed in the following sections, which include:

- **Trashracks.** See section 4.6.4.1.1 of this chapter.
- **Entrances.** See section 4.6.4.1.2 of this chapter.
- **Vertical curvature.** See section 4.6.4.1.3 of this chapter.

4.6.4.1.1 Trashracks

With few exceptions, an intake structure will include trashracks, which are needed to prevent debris from entering the intake structure with the flow, leading to possible plugging, or at least diminished discharge capacity. Initial sizing is based on a general consideration that the net surface area of the trashrack (openings) should be sufficient to limit average flow velocities to 1 to 2 ft/s for normal operations and 5 to 6 ft/s for flood or emergency operations. The size or gross (surface) area of the trashracks can be estimated by multiplying the net area by 1.25. For more details, see Chapter 5, “Hydraulic Considerations for Spillways and Outlet Works,” of this design standard.

4.6.4.1.2 Entrances

To minimize head losses and cavitation potential, the entrance to an intake structure should be streamlined to provide smooth, gradual changes in the flow. A bellmouth (elliptical) entrance that conforms to, or slightly encroaches upon, the free-jet profile (nappe-shape of an unsupported water jet) is the preferred entrance shape [5].

- **Circular entrance.** The bellmouth shape can be approximated by:

$$1 = \frac{x^2}{(0.5D)^2} + \frac{y^2}{(0.15D)^2} \quad \text{for horizontal entrance (for vertical entrance-reverse coordinates)}$$

Where: x is the coordinate whose x - x axis is parallel to and $0.65D$ from the entrance centerline (ft).
 y is the coordinate whose y - y axis is normal (perpendicular) to the entrance centerline and $0.5D$ from the entrance face (ft).
 D is the diameter of the conduit or tunnel at the downstream end of the entrance (ft).

- **Square or rectangular entrance.** The bellmouth shape for the top, bottom, and side contractions can be approximated by:

$$1 = \frac{x^2}{D^2} + \frac{y^2}{(0.33D)^2} \quad \text{for horizontal entrance (for vertical entrance-reverse coordinates)}$$

Where: x is the coordinate whose x - x axis is parallel to and $0.65D$ from the entrance centerline (ft).
 y is the coordinate whose y - y axis is normal (perpendicular) to the entrance centerline and $0.5D$ from the entrance face (ft).
 D is the vertical height of the conduit or tunnel at the downstream end of the entrance for the top and bottom curves and is the horizontal width of the conduit or tunnel at the downstream end of the entrance for the side curves (ft).

- **Square or rectangular entrance with bottom level with upstream floor.** The bellmouth shape for the top will need to accommodate a sharper contraction, while the sides and bottom contractions will be suppressed. The bellmouth shape for the top can be approximated by:

$$1 = \frac{x^2}{D^2} + \frac{y^2}{(0.67D)^2} \quad \text{for horizontal entrance}$$

Where: x is the coordinate whose x - x axis is parallel to and $0.65D$ from the entrance centerline (ft).
 y is the coordinate whose y - y axis is normal (perpendicular) to the entrance centerline and $0.5D$ from the entrance face (ft).
 D is the vertical height of the conduit or tunnel at the downstream end of the entrance for the top and bottom curve (ft).

For an illustration of a bellmouth entrance, see figure 4.6.4.1.2-1.

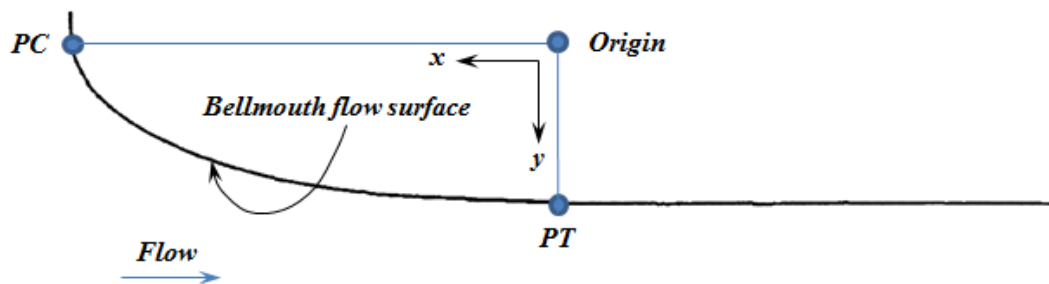

Figure 4.6.4.1.2-1. Bellmouth flow surface.

**Design Standards No. 14: Appurtenant Structures for Dams
(Spillways and Outlet Works) Design Standards**

4.6.4.1.3 Vertical Curvature

For some intake structures, such as the drop inlet, a vertical bend (curvature) will be part of the conveyance feature within the intake structure. The vertical bends should be defined by a radius (r) along the centerline of the conveyance feature within the intake structure, where the radius is typically equal to 1.5 to 2 times the wetted diameter of the conveyance features. Note: For noncircular conveyance feature shapes, use equivalent diameter.²²

4.6.4.2 Conveyance Features Hydraulics

Conveyance features located immediately upstream of an outlet works intake structure and downstream of an outlet works intake structure include approach channels, chutes, conduits, and/or tunnels. These conveyance features pass flow from the reservoir to and through the intake structures, as well as pass flow from the intake structure to the terminal structure. The conveyance feature (such as an approach channel) located immediately upstream of the intake structure is generally of less concern in terms of significant loading conditions that could lead to damage or failure of this feature, resulting in an uncontrolled release of the reservoir. However, it should be noted that (hydraulic) head losses associated with the approach channel should be accounted for in the computation of the discharge capacity of an outlet works. As a general guideline, the maximum average velocity in the approach channel should be less than or equal to maximum velocity through the intake structure trashracks (for more information, see Section 4.6.4.1.1, “Trashracks,” of this chapter).

The conveyance features (such as a chute, conduit, or tunnel) located immediately downstream of the intake structure are more likely to be subject to significant loading conditions (such as large flows and high velocities) that could potentially lead to damage or failure of this feature. Therefore, the focus of the following text is on the downstream conveyance feature. There are a number of hydraulic considerations that should be evaluated, as described in the following sections. These hydraulic considerations include:

- **Transitions.** See section 4.6.4.2.1 of this chapter.
- **Cavitation potential.** See section 4.6.4.2.2 of this chapter.
- **Freeboard for conveyance features.** See section 4.6.4.2.3 of this chapter.

²² Equivalent diameter is defined as four times the hydraulic radius (R) of the noncircular shape. For more details, see Chapter 5, “Hydraulic Considerations for Spillways and Outlet Works,” of this design standard.

- **Vertical curvature, horizontal curvature, and superelevation.** See section 4.6.4.2.4 of this chapter.
- **Stagnation pressure.** See section 4.6.4.2.5 of this chapter.

4.6.4.2.1 Transitions

The entrance and exit transition shapes are important to evaluate in terms of minimizing adverse hydraulic conditions.

- **Contractions and expansion.** To minimize head losses and cavitation potential, the contractions and expansions in pressurized or unpressurized conduits or tunnels should be gradual [5]. For more information about contractions and expansions in an unpressurized conduit or tunnel (open channel flow), see Chapter 3, “General Spillway Design Considerations,” of this design standard.
 - **Contractions.** For a pressurized condition, the maximum converging angle should not exceed the value estimated from the following equation:

$$\tan \alpha = \frac{1}{U}$$

- Where:
- α is the angle of the conduit wall surface with respect to its centerline (degrees).
 - U is a dimensionless parameter defined as $V_{AVG}/(gD_{AVG})^{1/2}$.
 - V_{AVG} is the average of the velocities at the beginning and end of the contraction (ft/s).
 - g is the acceleration due to gravity (ft/s²).
 - D_{AVG} is the average diameter (for circular section) or average equivalent diameter (for square or rectangular section) at the beginning and end of the transition (ft). For a definition of equivalent diameter, see Section 4.6.4.1.3, “Vertical curvature,” of this chapter.

- **Expansions.** For a pressurized condition, the maximum diverging angle should not exceed the value estimated from the following equation:

**Design Standards No. 14: Appurtenant Structures for Dams
(Spillways and Outlet Works) Design Standards**

$$\tan \alpha = \frac{1}{2U}$$

Where: α is the angle of the conduit wall surface with respect to its centerline (degrees).
 U is a dimensionless parameter defined as $V_{AVG}/(gD_{AVG})^{1/2}$.
 V_{AVG} is the average of the velocities at the beginning and end of the transition (ft/s).
 g is the acceleration due to gravity (ft/s²).
 D_{AVG} is the average diameter (for circular section) or average equivalent diameter (for square or rectangular section) at the beginning and end of the transition (ft).

- **Combining and dividing conveyance features.** It is not uncommon for conveyance features to be merged (combined) into one conveyance feature or divided (separated) into multiple conveyance features. An example is the bifurcation (dividing one into two) of a pressure conveyance feature immediately upstream of gates/valves. This might be done to provide more flexibility with releasing a larger range of flows and/or limiting the conveyance feature size to use available or feasible gate/valve sizes. Another advantage of a bifurcation in an outlet works is that if each downstream conduit has its own gate/valve arrangement (guard/emergency and regulating gates/valves), one conduit can be shut down (close guard/emergency gate/valve) for inspection or maintenance without unwatering the entire outlet works. Reclamation typically sizes the downstream wetted area(s) to be less than or equal to the upstream wetted area(s) of combined or divided conveyance features. However, for a pressurized system where gates/valves are located downstream of the combined or divided conveyance feature, hydraulic control will be maintained at a gate/valve (i.e., wetted area of the gate/valve will be smaller than the upstream wetted area of the conveyance feature), so it is not critical that the downstream wetted area(s) of the conveyance feature be equal to or less than the upstream wetted area(s) of the conveyance feature.

4.6.4.2.2 Cavitation Potential

Damage and/or failure of outlet works have resulted, and can result, from cavitation²³ (see figures 4.6.4.2.2-1 and 4.6.4.2.2-2). A case study includes

²³ Cavitation is defined as the formation of bubbles or voids in low pressure zones within a liquid (outlet works releases) due to flow surface irregularities and/or changes in flow surface geometry. The bubbles or voids pass into downstream higher pressure zones, rapidly collapse, and issue high pressure shock waves. If the collapsing bubbles or voids are near a flow surface, high frequency impacts occur, which result in fatigue and erosion of flow surface materials [31].

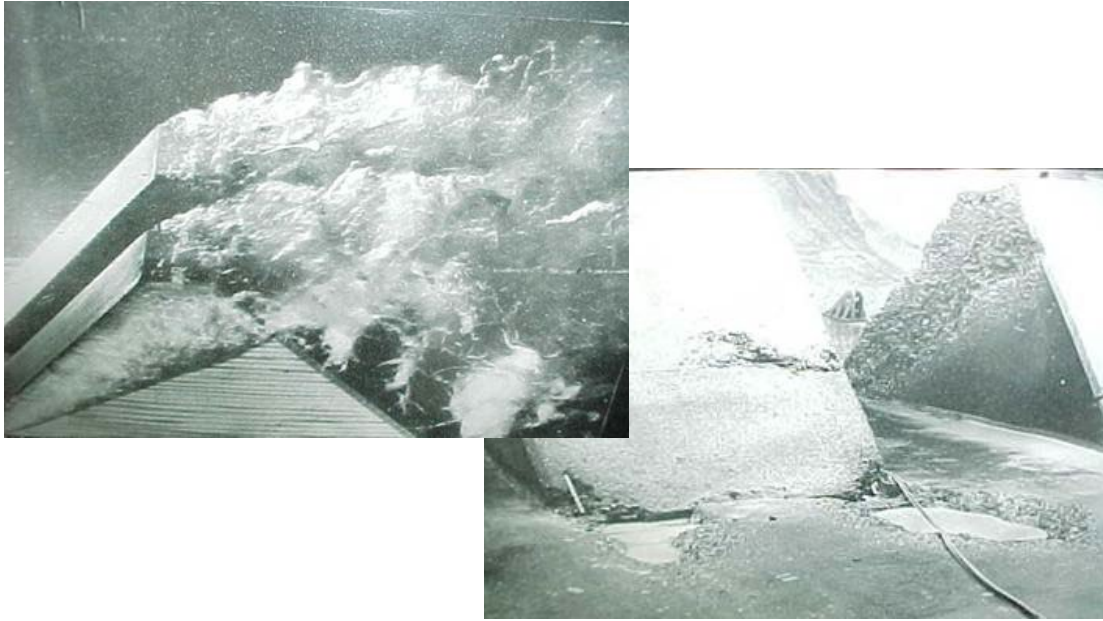

Figure 4.6.4.2.2-1. Cavitation simulation: (left) cavitation created in Reclamation’s low ambient pressure chamber; (right) cavitation damage noted after the test.

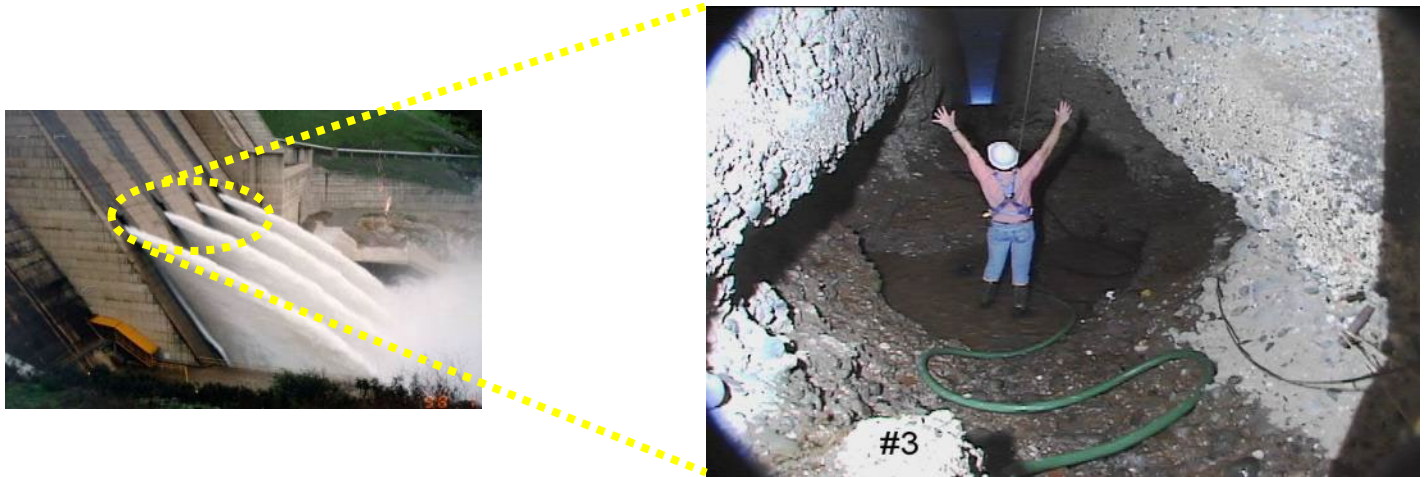

Figure 4.6.4.2.2-2. Cavitation damage occurred during operation of sluiceways at Folsom Dam, California. Root cause was determined to be inadequate aeration of flow immediately downstream of regulating gates. Remedial action included aeration slots and increased air supply downstream of regulating gates.

Design Standards No. 14: Appurtenant Structures for Dams (Spillways and Outlet Works) Design Standards

Folsom Dam sluice outlet works. Because of Reclamation's past experiences, considerable research and development have been undertaken to the point that most hydraulic analyses and designs of outlet works will include evaluation of cavitation potential and subsequent mitigation, if needed. Evaluation of cavitation potential is based on estimating the cavitation index (σ), which is a function of pressure and velocity [9, 31]:

$$\sigma = \frac{p - p_v}{\frac{\rho V^2}{2}} \text{ (cavitation index equation)}$$

Where:

- σ is the cavitation index.
- p is the pressure at the flow surface (atmospheric pressure plus hydrostatic pressure) (lb/ft²).
- p_v is the vapor pressure of water (typical value is 25.65 lb/ft² at 50 °F) (lb/ft²).
- ρ is the density of water which is temperature dependent (typical value is 62.4 lb/ft³ at 50 °F) (lb/ft³).
- V is the average flow velocity (ft/s).

General relationships between the cavitation indices and surface tolerances or roughnesses (T_S)²⁴ are summarized in Section 4.8.5.3, "Tolerances," of this chapter. As part of the standard step water surface profile analyses, cavitation indices profiles are estimated along the length of the conveyance feature. Details on evaluating and estimating cavitation potential are further addressed in Chapter 5, "Hydraulic Considerations for Spillways and Outlet Works," of this design standard.

4.6.4.2.3 Freeboard for Conveyance Features

In this case, freeboard is defined as the difference (in feet) between the water surface and the top of the walls of the chute or crown of the conduit or tunnel. Standard step water surface profile analyses are made to determine depth of flow and average velocity along the length of the conveyance feature. Details on evaluating and estimating freeboard for conveyance features are further addressed in Chapter 5, "Hydraulic Considerations for Outlet Works and Outlet Works," of this design standard. There are a number of cases associated with outlet works where freeboard should be evaluated, including:

²⁴ Surface roughnesses or tolerances (T_S) are defined by an offset (isolated abrupt surface irregularities where the dimension of the irregularity perpendicular to the flow is large relative to its dimension parallel with the flow) and slope (variations caused by surface irregularities where the dimension parallel with the flow is large relative to the variation perpendicular to the flow) [31].

- For existing and new outlet works conduits and tunnels that are designed to remain in free flow conditions.** The wetted area should generally not exceed 75 percent of the total area of the conduit or tunnel at the downstream end during maximum discharge [5]. Under this limitation, air will be able to pass up the conduit or tunnel from the downstream end and prevent the formation of subatmospheric pressure. Subatmospheric pressure could lead to unstable flow conditions (such as slug-flow) and/or pressurization of the conduit or tunnel. Also, upstream venting of the conduit or tunnel has been and can be used to help prevent the formation of subatmospheric pressure. However, it is not advisable to rely solely on upstream venting and allowing the wetted area to exceed 75 percent of the total downstream area of the conduit or tunnel. Finally, care should be taken with the evaluation of the vertical and horizontal curvatures of the conduit or tunnel profile and alignment to ensure that sealing does not occur along some portion by surging, air bulking, or wave action.
- For new outlet works channels or chutes.** In many cases, a chute is used to transition flows from the downstream end of a conduit or tunnel to a terminal structure or exit channel. In these cases, Reclamation uses an empirical relationship for freeboard, which is a function of average flow velocity (V) and depth of flow (d) [5]. This freeboard estimate is used to establish the minimum chute wall height and is typically associated with the design discharge, supercritical flow condition, and accounts for flow surface roughness, wave action, air bulking, splash, and spray.

$$FB_C = 2 + 0.025V(d)^{\frac{1}{3}} \text{ (chute wall freeboard equation)}$$

Where: FB_C is the minimum freeboard above the water surface (ft).
 V is the average flow velocity (ft/s).
 d is the flow depth (ft).

Additional guidance on analytically evaluating air entrainment and air bulking can be found in Engineering Monograph No. 41, *Air-Water Flow in Hydraulic Structures* [32].

- For existing outlet works channels or chutes.** Releasing more than the original design discharge may result in freeboard encroachment up to overtopping the channel or chute, leading to adverse flow conditions and damage or progressive failure of the conveyance features, and uncontrolled release of part or the entire reservoir. To further evaluate this condition, air entrainment and air bulking potential should be estimated [9].

4.6.4.2.4 Vertical Curvature, Horizontal Curvature, and Superelevation

For pressurized flow conditions, the vertical and horizontal bends (curvature) should be defined by a radius (r) along the centerline of the conveyance features (pipe, conduit, or tunnel) where the radius is greater than or equal to three times the

Design Standards No. 14: Appurtenant Structures for Dams (Spillways and Outlet Works) Design Standards

(equivalent) diameter of the conveyance features. Note: For noncircular conveyance feature shapes, use equivalent diameter.

In some cases, where unpressurized conditions exist in a conduit, tunnel, channel, or chute associated with an outlet works, a vertical and/or horizontal change in direction may be needed as a result of operational considerations, along with site-specific topography and/or geology. These changes in direction are addressed through vertical and horizontal curves.

- **Vertical curvature.** Vertical curvature is used to change the orientation/direction of the conveyance features (i.e., applicable to chutes, tunnels, and conduits). Both concave²⁵ and convex²⁶ curvatures have and can be used in the design of conveyance features [5].

For concave curvature, generally used for the downstream chute conveyance feature or between the chute conveyance feature and a flip bucket terminal structure, simple (circular) curves can be used. An approximate relationship, which provides a minimum curvature, is defined by the following equation:

$$r = \frac{2qV}{p_F} \Rightarrow r = \frac{2dV^2}{p_F}$$

Where:

r is the minimum radius of curvature (ft).

q is the unit discharge (ft³/s/ft).

V is the average velocity (ft/s).

d is the flow depth (ft).

p_F is the normal dynamic pressure exerted on the flow surface (lb/ft²).

The minimum radius (r) should not be less than $10d$. When selecting the radius of curvature (r), consider both the minimum value of $10d$ and the resulting dynamic pressure (p_F). The dynamic pressure must be included in the structural and stability design of the conveyance feature (including foundation considerations).

For convex curvature, vertical (parabolic) curves should be used and should be flatter than the trajectory of a free jet to prevent separation of flow from the flow surface (see Section 4.6.4.4.3, “Trajectory of a Free Jet,” of this chapter for more details about estimating trajectory of a free

²⁵ Concave is defined as inward curvature.

²⁶ Convex is defined as outward curvature.

Chapter 4: General Outlet Works Design Considerations

jet). The following vertical curve equation can be used to lay out the flow surface. Also, when checking the vertical curve with the free jet trajectory equation found in Section 4.6.4.4.3, “Trajectory of a Free Jet,” in this chapter, use $k = 1.5$).

$$y = \frac{r_{slp}}{2}x^2 + G_1x + PC \text{ (vertical or parabolic curve)}$$

Where:

- y is the elevation of a point on the curve (ft).
- x is the distance in stations (sta) between the point of curvature (PC) and a point along the curve (one station = 100 ft).
- r_{slp} is the rate of change of grade (slope) per station, where:
$$r_{slp} = \frac{(G_2 - G_1)}{L_{STA}}$$
- G_1 is the initial grade (%). G_2 is the final grade (%). A downward slope has a negative value.
- L_{STA} is the length in stations of the curve (horizontal distance between the beginning of the curve or PC , and the end of the curve or point of tangency [PT] (sta).
- PC is the elevation at the beginning of the curve or point of curvature PC (ft).

To clarify the vertical curve equation, see figure 4.6.4.2.4-1. Also, the procedure for sizing a vertical curve is:

1. Select upstream and downstream grades (G_1 and G_2).
For a downward slope of 1 foot in 100 feet, the grade would have a value of -1.0 percent.
2. Select a length for the vertical curve (L_{STA}).
For a 30-foot vertical curve, the length would be 0.30 stations
3. Compute the PC and points along the curve.
4. Compute the water (free) jet trajectory as a check, using $k = 1.5$.
5. If vertical curve is flatter than trajectory, curve can be shortened and re-estimated.
6. If trajectory is flatter than the vertical curve, lengthen the curve and re-estimate.

**Design Standards No. 14: Appurtenant Structures for Dams
(Spillways and Outlet Works) Design Standards**

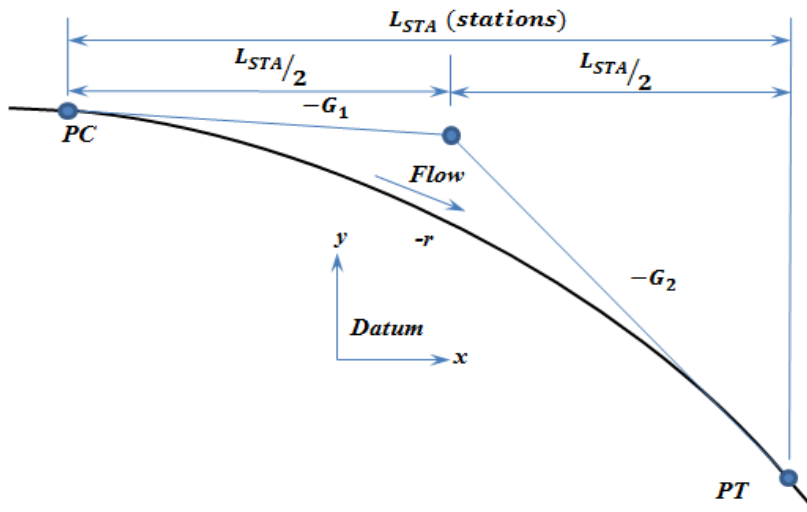

Figure 4.6.4.2.4-1. Parabolic vertical curve illustration.

- **Horizontal curvature.** Based on details concerning horizontal curvature in channels found in the U.S. Army Corps of Engineers' *Hydraulic Design of Flood Control Channels*, Engineering Manual (EM) 1110-2-1601 [33], the following guidance is provided to the reader.

As previously noted, the best hydraulic performance in a discharge channel (such as an outlet works conduit or tunnel flowing partially full or a transition chute connecting a conduit or tunnel downstream portal with a terminal structure) is achieved when the channel walls are parallel to the direction of flow. However, in some cases, horizontally curved channels are employed to better adapt to the operation, topography, and/or geology. In this case, the curved outlet works channel (conduit, tunnel, and/or chute) causes the water surface to rise on the outside wall and lower on the inside wall, which is due to centrifugal force. This condition is called "superelevation" (see "Superelevation" bullet below for more details). Horizontal curvature can be used in the conveyance features that are upstream or downstream of the outlet works intake structure.

Conveyance features upstream of the intake structures and flowing partially full (such as approach channels) are typically associated with subcritical flows (i.e., Froude number is less than 1.0). For this condition, the horizontal curvature at the centerline of the channel or structure should be at least three times the channel or structure width and can be defined by a simple (circular) curve.

Conveyance features downstream of control structures (such as chutes, tunnels, and conduits) are typically associated with supercritical flows (i.e., Froude number is greater than 1.0). For this condition, adverse

Chapter 4: General Outlet Works Design Considerations

hydraulics in the form of cross waves and standing waves can result, which could lead to elevated water surfaces and unsymmetrical flow conditions. To minimize adverse hydraulics, spiral transition curves in combination with simple (circular) curves should be used.

For an unbanked flow surface, the spiral transitions upstream and downstream of a simple curve can be estimated by the following equation:

$$L_s = \frac{1.82VT}{\sqrt{gd}} \text{ (upstream and downstream spiral length for unbanked curve)}$$

Where: L_s is the minimum length of the upstream and downstream spirals for unbanked curves (ft).
 V is the average velocity (ft/s).
 T is the conveyance feature width at the water surface (ft).
 g is the acceleration due to gravity (ft/s²).
 d is the flow depth (ft).

For a banked flow surface, the spiral transitions upstream and downstream of a simple curve can be estimated by the following equation:

$$L_s = 30\Delta y \text{ (upstream and downstream spiral length for banked curve)}$$

Where: L_s is the minimum length of the upstream and downstream spirals for banked curves (ft).
 Δy is the total rise in water surface on outside wall (ft). See the “Superelevation” bullet below for more details.

For an unbanked or banked flow surface, the radius of the simple curve, in combination with the spiral transitions upstream and downstream of the simple curve, should not be less than the estimate provided by the following equation:

$$r_{\min} = \frac{4V^2T}{gd} \text{ (minimum radius of simple curve)}$$

Where: r_{\min} is the minimum radius of the simple curve around the centerline of the channel or structure (ft).
 V is the average velocity (ft/s).
 T is the conveyance feature width at the water surface (ft).
 g is the acceleration due to gravity (ft/s²).
 d is the flow depth (ft).

**Design Standards No. 14: Appurtenant Structures for Dams
(Spillways and Outlet Works) Design Standards**

- Superelevation.** Based on details concerning superelevation in channels found in the U.S. Army Corps of Engineers' *Hydraulic Design of Flood Control Channels*, EM 1110-2-1601 [33], the following equation can be used to approximate the total rise in the water surface for both unbanked and banked flow surfaces along horizontal curvature (see figure 4.6.4.2.4-2) [9, 33]:

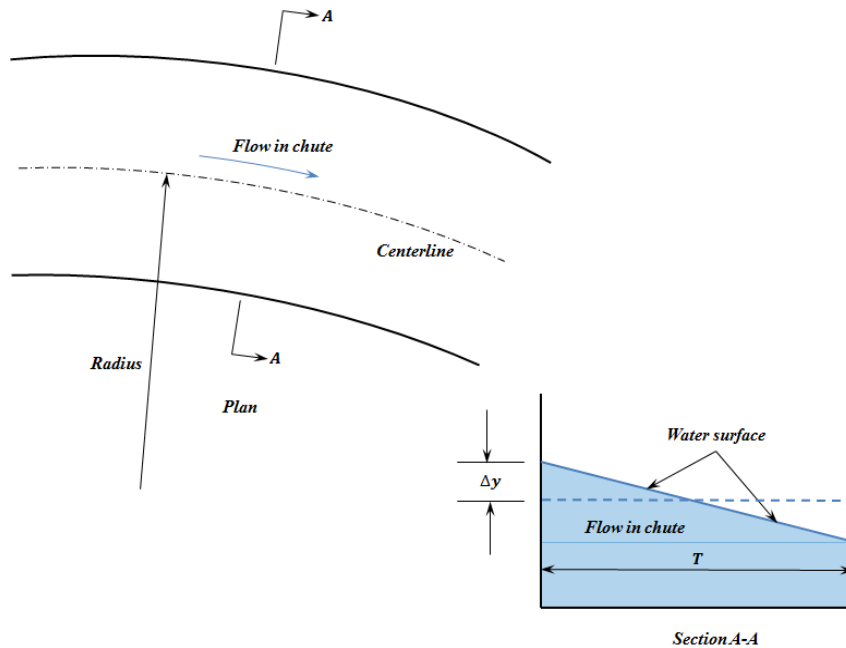

Figure 4.6.4.2.4-2. Superelevation illustration.

$$\Delta y = \frac{C_{SE} V^2 T}{gr} \text{ (total rise in water surface)}$$

- Where:
- Δy is the total rise in water surface on the outside wall (ft).
 - C_{SE} is a coefficient ranging from 0.5 for all subcritical flow and for chutes with spiral transitions or spiral banks to 1.0 for trapezoidal channels subject to supercritical flow and for rectangular channels with circular curves subject to supercritical flow.
 - V is the average flow velocity (ft/s).
 - T is the channel width at elevation of centerline of water surface (ft).
 - g is acceleration due to gravity (ft/s²).
 - r is the radius of channel centerline curvature (ft).

Note: When dealing with horizontal curvature associated with conveyance features, the total freeboard should include the superelevation estimate (Δy) and the value estimated in Section 4.6.4.2.3, “Freeboard for Conveyance Features” in this chapter.

4.6.4.2.5 Stagnation Pressure

Damage and/or failure of conveyance features have resulted and can result from stagnation pressure,²⁷ sometimes referred to as “hydraulic jacking.” Although there are no case histories associated with Reclamation’s inventory of outlet works, there is potential for stagnation pressure damage and/or failure similar to some of the stagnation pressure incidences associated with Reclamation’s inventory of spillways (such as Big Sandy Dam service spillway). Because of Reclamation’s past experiences, considerable research and development have taken place and have been incorporated into most hydraulic analyses, and designs of outlet works will include evaluation of stagnation pressure potential and subsequent mitigation, if necessary [9, 34].

Assessment of stagnation pressure potential is based on inspecting flow surfaces for existing outlet works, evaluating floor joint details and floor cracking for both existing and new outlet works, and estimating uplift pressures (beneath the flow surface) based on average flow velocities, joint opening, and/or crack size. As part of the standard step water surface profile analyses, average velocity profiles are used to estimate uplift profiles along the length of the conveyance feature. Details on evaluating and estimating stagnation pressure potential are further addressed in Chapter 5, “Hydraulic Considerations for Spillways and Outlet Works,” of this design standard.

4.6.4.3 Control Structures Hydraulics

Control structures are features or components of an outlet works that contain gates or valves used to control the flow through the outlet works. As previously noted in Section 4.5.2.2.4, “Control Structure,” of this chapter, control structures could be:

- Incorporated into the intake structure, such as a wet-well tower (hydraulic control arrangement 3);

²⁷ Stagnation pressure refers to two conditions that can result in damage and/or failure of the outlet works: (1) high velocity, high-pressure flows enter cracks or open joints in the outlet works flow surface (such as a transition chute between the downstream portal of a conduit or tunnel and a terminal structure), which results in uplift pressure that lifts (displaces) portions of the outlet works conveyance feature; and (2) High velocity, high-pressure flows enter the foundation through cracks or open joints in the outlet works flow surface, which results in internal erosion of the foundation and loss of support of portions of the outlet works conveyance feature [34].

Design Standards No. 14: Appurtenant Structures for Dams (Spillways and Outlet Works) Design Standards

- Located between the intake structure and the terminal structure, such as a gate chamber (hydraulic control arrangement 1 or 2); or
- Located at the downstream end of the outlet works, such as a control house (arrangement 1 or 4).

Maintaining hydraulic control at the gate or valve is a common hydraulic consideration that applies to most control structures. This is accomplished by establishing the wetted area of a fully open gate or valve to less than the wetted area of the upstream conveyance features. As a general guideline, the upstream conveyance features should have a wetted area greater than or equal to 1.1 times the wetted area of the gate or valve. Another general guideline is to include a straight section of the conveyance feature upstream and downstream of the gate or valve greater than or equal to 5 times the diameter of the upstream and downstream pipe.

4.6.4.4 Terminal Structures Hydraulics

Terminal structures located immediately downstream of the conveyance features include stilling basins, energy dissipators, and flip buckets (figure 4.6.4.4-1). These structures are intended to dissipate or manage the kinetic energy of the flow, so it can be returned to the river or stream without significant scour or erosion that could damage or fail the dam and appurtenant structures [5].

For sizing of symmetrical, typical terminal structures, procedures found in EM No. 25, *Hydraulic Design of Stilling Basins and Energy Dissipators* [35], and Research Report No. 24, *Hydraulic Design of Stilling Basins for Pipe or Channel Outlets* [36], are used. These procedures are based on Reclamation's designs of hundreds of terminal structures. For asymmetrical, atypical terminal structures and/or for releases outside the ranges noted in this reference, other design and analysis approaches are used including finite volume analysis, commonly referred to as computational fluid dynamics (CFD), and physical modeling. Details on hydraulically evaluating, analyzing, and designing terminal structures are further addressed in Chapter 5, "Hydraulic Considerations for Spillways and Outlet Works," of this design standard.

There are a number of hydraulic considerations associated with terminal structures that are highlighted in the following sections. These hydraulic considerations include:

- **Freeboard for terminal structures.** See section 4.6.4.4.1 of this chapter.
- **Minimum radius of curvature.** See section 4.6.4.4.2 of this chapter.
- **Trajectory of a free jet.** See section 4.6.4.4.3 of this chapter.

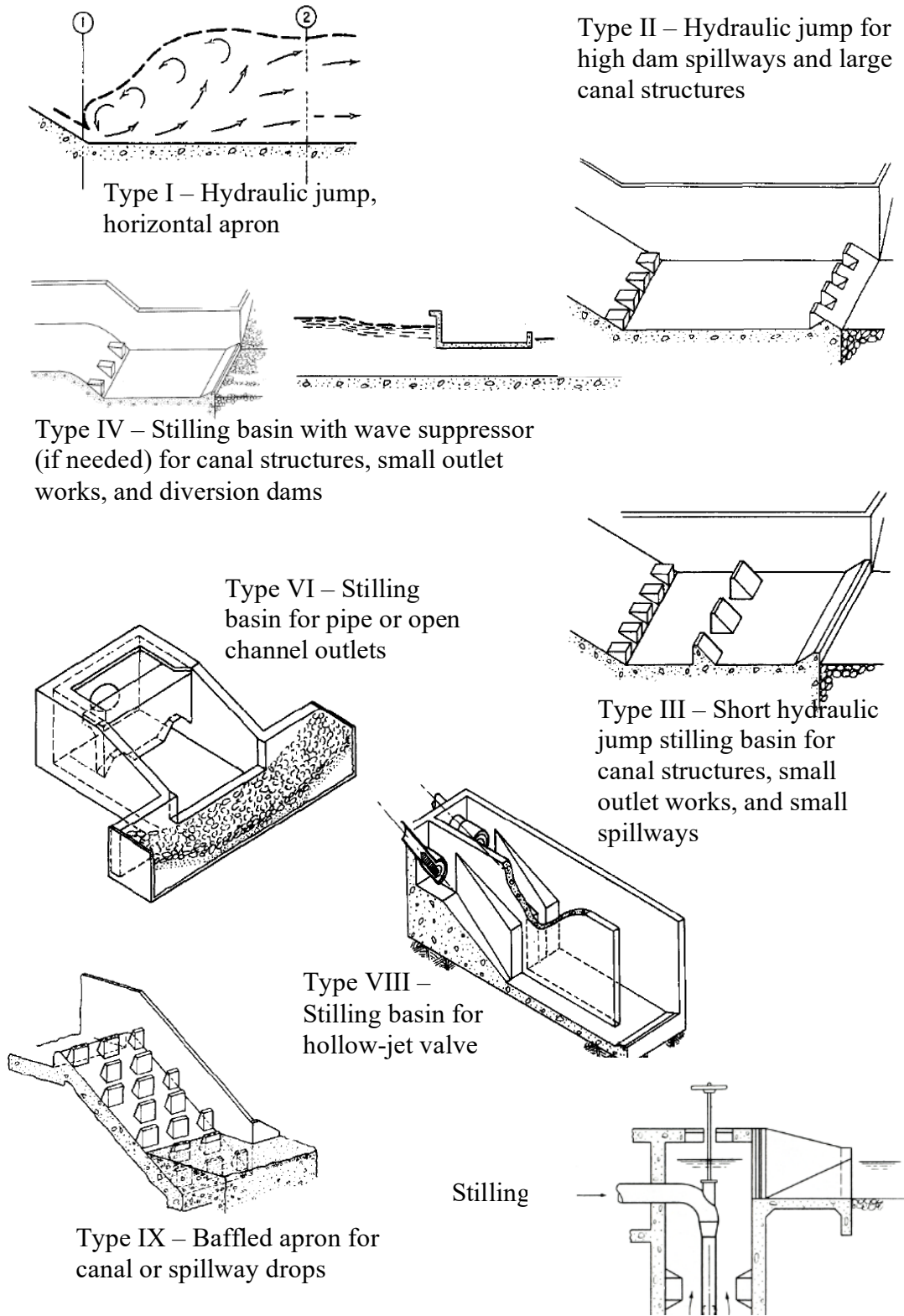

Figure 4.6.4.4-1. Terminal structures.

**Design Standards No. 14: Appurtenant Structures for Dams
(Spillways and Outlet Works) Design Standards**

4.6.4.4.1 Freeboard for Terminal Structures

For terminal structures such as stilling basins, the freeboard is defined as the difference (in feet) between the water surface and the top of the walls. The most common terminal structure employed by Reclamation is the hydraulic jump stilling basin. For this terminal structure, the standard step water surface profile analyses are performed to determine initial flow depths (d_1) and average velocity (V_1) before the hydraulic jump (entering the stilling basin). Then, the force-momentum relationship is used to determine the flow depth or conjugate depth (d_2) after the hydraulic jump (exiting the stilling basin) [5]. This relationship is expressed by the following equation and applies to all hydraulic jump terminal structures with horizontal floors and vertical walls:

$$\frac{d_2}{d_1} = \frac{\sqrt{1 + 8F^2} - 1}{2}$$

Where: d_2 is the conjugate depth or depth at the downstream end of the hydraulic jump (ft).
 d_1 is the depth of flow entering the stilling basin (ft).
 F is the Froude number entering the stilling basin = $V_1 / (gd_1)^{1/2}$.
 V_1 is the average velocity entering the stilling basin (ft/s).

The following empirical expression has proven to provide acceptable freeboard estimates for most situations:

$$FB_T = 0.1(V_1 + d_2) \text{ (terminal structure wall freeboard equation) [5]}$$

Where: FB_T is the minimum freeboard above the water surface (ft).
 V_1 is the average velocity entering the stilling basin (ft/s).
 d_2 is the conjugate depth or depth at the downstream end of the hydraulic jump (ft).

4.6.4.4.2 Minimum Radius of Curvature

For some terminal structures, such as a flip bucket, concave curvature of the flow surface is used to establish a trajectory of the discharge to a point downstream where the kinetic energy can be safely dissipated. As previously discussed in Section 4.6.4.2.4, “Vertical Curvature, Horizontal Curvature, and Superelevation,” of this chapter, an approximate relationship that establishes a minimum radius for concave curvature is defined by the following equations:

$$r = \frac{2qV}{p_F} \Rightarrow r = \frac{2dV^2}{p_F}$$

Where: r is the minimum radius of curvature (ft).
 q is the unit discharge (ft³/s/ft).
 V is the average velocity (ft/s).
 d is the flow depth (ft).
 p_F is the normal dynamic pressure exerted on the flow surface (lb/ft²).

The minimum radius (r) should not be less than $5d$. When selecting the radius of curvature (r), consider both the minimum value of $5d$ and the resulting dynamic pressure (p_F). The dynamic pressure must be included in the structural and stability design of the conveyance feature (including foundation considerations).

4.6.4.4.3 Trajectory of a Free Jet

For some terminal structures, such as a flip bucket or overtopping a concrete dam, it is important to estimate the trajectory of discharge to determine the downstream impingement area (such as a plunge pool), which must be capable of dissipating much of the kinetic energy. It has been determined that the trajectory equation noted in *Design of Small Dams*, 3rd edition, Chapter 9, “Spillways,” equations 19 and 23 overestimate the trajectory (i.e., estimate a flatter path) [5]. In lieu of using that equation, the following equation should be used to estimate the free jet trajectory [37] (also, for clarification, see figure 4.6.4.4.3-1):

$$y = x \tan \theta_0 - \frac{x^2}{4kh_v \cos^2 \theta_0}$$

Note: If the brink is horizontal (i.e., $\theta_0 = 0$ degrees), the previous equation reduces to:

$$y = -\frac{x^2}{4kh_v} = \frac{x^2}{2V_b^2}$$

Where: $k = 1.0$ is the trajectory coefficient used to alter the undernappe shape (flatter or steeper than unsupported free jet). When $k = 1.0$, undernappe follows a free jet trajectory; and when $k > 1.0$, undernappe is flatter than free jet trajectory.
 $h_v = h_{vb}$ is velocity head at brink of jet springing free from flip bucket or dam crest (ft) = $V_b^2/2g$.
 V_b is the brink velocity (ft/s) for the flip bucket. For concrete dam overtopping, $V_b = 1.399V_c = 0.808(2gH)^{0.5}$.
 V_c is the critical velocity (ft/s) = $Q/(L d_c)$.

**Design Standards No. 14: Appurtenant Structures for Dams
(Spillways and Outlet Works) Design Standards**

- d_c is the critical depth occurring upstream of brink where jet springs free from dam (ft) = $0.67H$.
- H is the total head or overtopping depth of dam (ft).
- L is the crest length (ft).
- Q is the total discharge (ft³/s).
- θ_0 is the initial angle of the jet from horizontal at the brink of jet springing free from the flip bucket or dam crest (degrees).
 θ_0 is positive if the jet is initially inclined upward and negative if the jet is initially inclined downward.

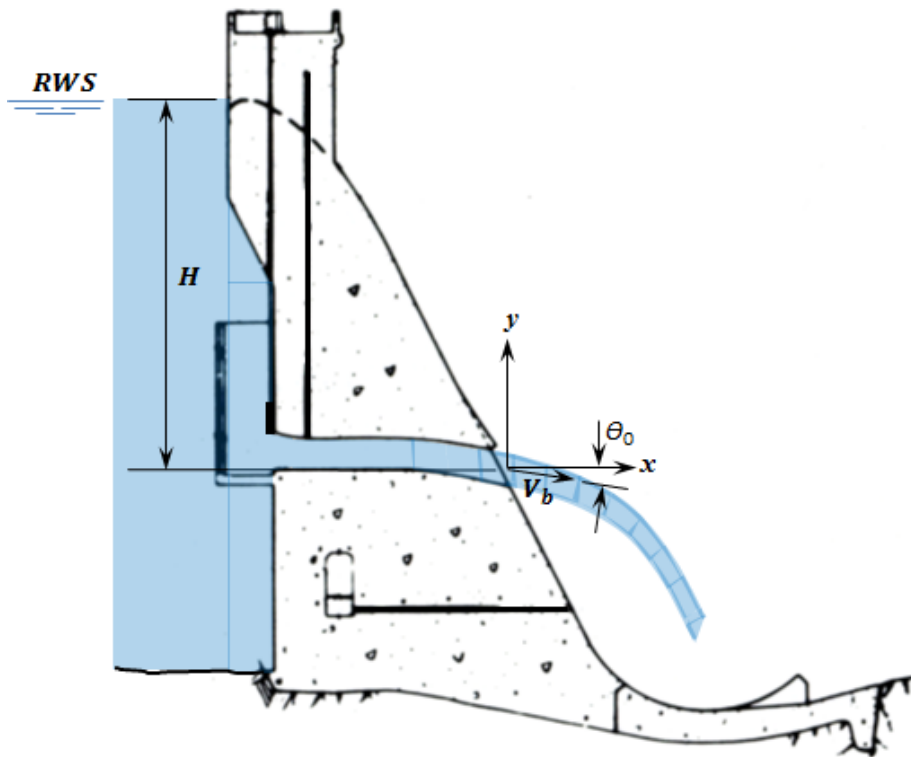

Figure 4.6.4.4.3-1. Trajectory of a free jet illustration. Note: Jet is exiting a pressurized outlet works, which changes downstream reference from the floor to the centerline of the downstream exit.

4.6.4.5 Erosion Protection

Erosion protection is a key consideration when evaluating existing outlet works and designing new outlet works. Primary applications of erosion protection include: armoring upstream outlet works approach channels and downstream outlet works exit channels, along with armoring plunge pool terminal structures. For more information about erosion, see Chapter D-1, “Erosion of Rock and Soil,” of *Best Practices* [9].

- **Estimating erosion potential.** The initial step in determining if erosion protection is needed involves evaluating erosion potential of the soil or rock channel materials.
 - **For soil channel materials,** erosion potential can be initially assessed using procedures found in Reclamation’s *Computing Degradation and Local Scour – Technical Guideline for Bureau of Reclamation* [38]. The recommended approach uses a number of empirical equations based on experimental and prototype studies.

For a more detailed erosion potential evaluation, the SITES method²⁸ is used, which was developed by the U.S. Department of Agriculture.

For a preliminary assessment of soil erosion due to a plunging water jet (i.e., estimating plunge pool erosion potential associated with a flip bucket terminal structure), a number of empirical relationships follow.

$$Y_S = 1.90H^{0.225}q^{0.54} \cos \alpha_S \text{ (Yildiz and Unzucek equation) [9, 39]}$$

Where: Y_S is the depth of erosion below tailwater (meters [m]).
 H is the elevation difference between the reservoir and tailwater surface (m).
 q is the unit discharge (cubic meters per second per meter [$m^3/s/m$]).
 α_S is the water jet impingement angle with the tailwater from vertical (degrees).

$$Y_S = \frac{K_S(q^X H^Y h_S^{0.15})}{g^{0.3} d_S^{0.1}} \text{ (Mason and Arumugan equation) [9, 40]}$$

Where: Y_S is the depth of erosion below tailwater (m).
 H is the elevation difference between the reservoir and tailwater surface (m).
 q is the unit discharge ($m^3/s/m$).
 h_S is the tailwater depth above original ground surface (m).
 K_S is equal to $6.42-3.1H^{0.10}$.
 g is the acceleration due to gravity (meters per second squared [m/s^2]).
 d_S is the median grain size (D_{50}) (m).
 X is equal to $0.6-H / 300$.
 Y is equal to $0.15+H / 200$.

²⁸ SITES method <http://www.nrcs.usda.gov/technical/Eng/sites.html> is based on observed behavior of soil and grass-lined spillways.

**Design Standards No. 14: Appurtenant Structures for Dams
(Spillways and Outlet Works) Design Standards**

- **For rock and soil channel materials**, erosion potential can be initially assessed by comparing erodibility index²⁹ to stream power³⁰ (see figure 4.6.4.5-1). Rock erosion is governed primarily by the spacing and orientation of the discontinuities, with the properties of the intact rock being less important, except in very soft material. The concept of rock mass index correlated with power, and how it relates to removing rock by flowing water, is expressed as the erodibility index. The erodibility index has been further correlated empirically to the erosive power of flowing water, which is termed “stream power.” This correlates data used to develop the stream power erodibility index relationship based on logistic regression [41]. The governing equations for the stream power-erodibility index method are noted below:

$$K_h = M_s K_b K_d J_s \text{ (erodibility index equation)}$$

Where:

- K_h is the erodibility index.
- M_s is the mass strength for the rock (i.e., uniaxial compressive strength) – (megapascals [MPa]).
- K_b is the particle or fragment size that forms the mass (based on joint spacing or rock mass classification parameters) equal to RQD/J_n .
- K_d is the interblock strength equal to J_r/J_a , which is based on Barton’s Q-system.³¹ J_r is the joint roughness number, and J_a is the joint alteration number.
- J_s is a factor that accounts for the relative shape and orientation of the rock blocks.³²
- J_n is a modified joint set number.³³
- RQD is the rock quality designation, which is determined by measuring the core recovery percentage of core chunks that is greater than 100 millimeters in length, ranging from less than 25 percent (very poor) to 90-100 percent (excellent).

²⁹ Erodibility index is the rock or soil mass properties index which characterizes the potential removal due to flowing water. The erodibility index is a function of mass (intact) strength of the rock or soil, mean block size of the rock or soil, interblock friction resistance, and the orientation of the rock or soil feature relative to the flowing water.

³⁰ Stream power is the rate of energy (power) dissipation, which is a function of flow depth, flow velocity, and the energy grade line.

³¹ Refer to chapter D-1, “Erosion of Rock and Soil,” of *Best Practices* [9], for suggested values.

³² Ibid.

³³ Ibid.

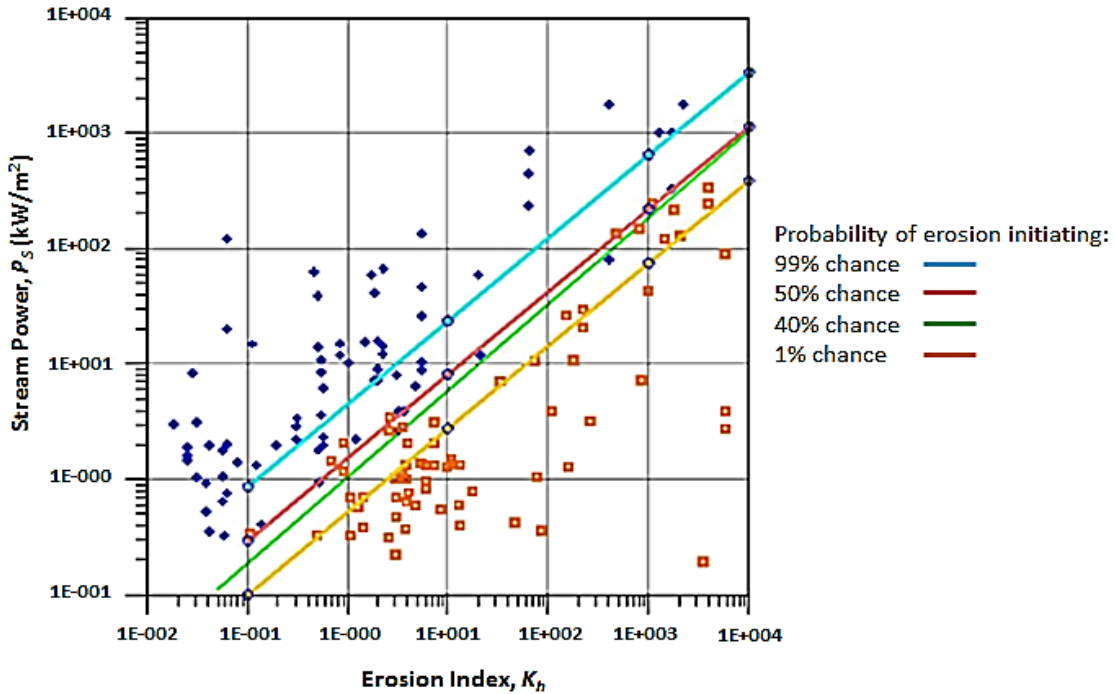

Figure 4.6.4.5-1. Erosion potential – erodibility index versus stream power [41].

$P_S = \gamma_w V d S$ (stream power equation for surface flows), and

$$P_S = \frac{\gamma_w Q Z}{A} \quad (\text{stream power equation for free fall jet})$$

Where:

- P_S is the rate of energy (power) dissipation (kilowatts per square meter [kW/m²]).
- γ_w is the unit weight of water (kilonewton per cubic meter [kN/m³]).
- V is the average velocity of flow (meters per second [m/s]).
- d is the depth of flow (m).
- S is the slope of the energy grade line.
- Q is the total discharge at the location being examined (cubic meters per second [m³/s]).
- Z is the head or height from which the free jet falls (m).
- A is the area of the jet as it impacts the rock or soil surface (square meters [m²]).

Once erodibility indices (K_h) and stream power values (P) have been estimated, they can be compared (plotted) on figure 4.6.4.5-1 to determine the likelihood of erosion initiation. It should be noted that likelihood of erosion initiating can be interpolated between lines noted on figure 4.6.4.5-1.

**Design Standards No. 14: Appurtenant Structures for Dams
(Spillways and Outlet Works) Design Standards**

- **Determining erosion protection requirements.** Erosion channel protection can include vegetative cover (grass), riprap, grouted riprap, gabions, RCC, soil cement, and precast concrete blocks. For more information about vegetative cover, gabions, RCC, soil cement, and precast concrete blocks, refer to the *Technical Manual: Overtopping Protection for Dams* [42].

Riprap is one of the most common erosion channel protection materials Reclamation uses. Design of riprap armorment includes determining the median rock size or D_{50} (i.e., 50 percent of rock is smaller than D_{50}), thickness of riprap layer, gradation of riprap and bedding layer (if needed), and edge treatment [43]. Additional information can be found in Chapter 5, “Hydraulic Considerations for Spillways and Outlet Works,” of this design standard.

For some types of outlet works terminal structures, erosion protection may be required for the concrete flow surfaces. This could be due to abrasion from high velocity flows or high levels of sediment being passed. The concrete may be protected by increasing the thickness of the concrete (increasing clear cover) to provide a sacrificial layer of concrete. For the regulating valves (fixed-cone valves) at Jordanelle Dam, a steel liner was used in the energy dissipation structure to protect the concrete from high velocity flow induced erosion.

4.7 General Foundation Considerations

This section provides general foundation considerations for determining the type, location, and size of a modified or new outlet works. Detailed foundation analysis and design can be found in Chapter 6, “Structural Considerations for Spillways and Outlet Works,” of Design Standards No. 4, “Water Conveyance Facilities, Fish Facilities, and Roads and Bridges.”

As previously noted, and unless specified otherwise, this chapter is applicable to the evaluation, analysis, and design of reinforced concrete, high velocity, and high-flow outlet works.

4.7.1 Elastic Foundation

The following discussion relates to cut-and-cover outlet works, which includes both surface and subsurface structures. Surface structures could include intake structures, chutes, and terminal structures, while subsurface structures could

Chapter 4: General Outlet Works Design Considerations

include conduits, gate chambers, and shafts which are embedded within an embankment dam. This section does not apply to tunnel outlet works features such as a tunnel conveyance feature and gate chamber control structure. For more information about tunnel foundation considerations, see Chapter 4, “Tunnels, Shafts, and Caverns,” of Design Standards No. 3 – Water Conveyance Facilities, Fish Facilities, and Roads and Bridges [23].

Although it is highly recommended that a competent rock foundation be located and prepared for an outlet works, a soil foundation can be acceptable if appropriate design and construction methods are employed. Due to the range of foundation types (rock and/or soil), designs for outlet works include a determination of the base pressure for an elastic foundation. General assumptions include:

- The foundation is elastic (i.e., settlement at any point is proportional to the pressure at that point).
- Analyses and designs are typically based on a two-dimensional beam on an elastic foundation.
- The foundation modulus³⁴ is the elastic deformation resulting from unit pressure, or elastic uplift that results from a unit tension.

Reclamation would not consider a foundation suitable for an outlet works if the foundation modulus was less than 200 pounds per square inch per inch ($\text{lb}/\text{in}^2/\text{in}$) (elastic deformable foundation, typically associated with soft compressible soils). Suitable foundation modulus ranges have been at least $200 \text{ lb}/\text{in}^2/\text{in}$ to $2,000 \text{ lb}/\text{in}^2/\text{in}$ or greater (very rigid foundation, typically associated with firm formation or rock). A reasonable range of foundation moduli is used in a typical design. This range can be based on field and laboratory test data, technical references using field data, or assumptions based on experience and/or observations. By using a range of foundation moduli, magnitudes, and locations of maximum and minimum foundation stresses (moments and shears) acting on an outlet works floor slab (such as an intake structure, chute, and/or terminal structure) foundation stresses can be determined. For those features that are embedded in an embankment dam (such as conduits and gate chambers or shafts), estimated foundation displacement, due to dam and foundation settlement over time, will typically be the key consideration for the subsurface features of an outlet works. For the surface features of an outlet works, the critical locations of maximum moments and shears include the slab-wall interfaces and the center of the slab.

³⁴ Foundation modulus is also referred to as the modulus (coefficient) of subgrade reaction.

Design Standards No. 14: Appurtenant Structures for Dams (Spillways and Outlet Works) Design Standards

While most rock foundations for an outlet works can be made acceptable with some preparation, more care is needed in evaluating whether a soil foundation for an outlet works can be made acceptable (see Chapter 6, “Structural Considerations for Spillways and Outlet Works,” of this design standard). The following guidelines are provided, based on the Unified Soil Classification System (USCS) [44],³⁵ and should be applied on a case-by-case basis:

- In terms of foundation compressibility, the following bullets list soils in decreasing order of acceptable foundations:
 - Soils are generally acceptable foundation materials for surface features for an outlet works if they are gravel and gravelly soils (GW, GC, GP, and GM) or sands and sandy soils (SW, SC, SP, and SM).
 - Soils that may be suitable foundation materials for surface features for an outlet works but may require some additional evaluation, design, and foundation preparation or treatment are fine-grained soils (silts and clays) having low to medium compressibility (ML and CL).
 - Soils that are unlikely to be suitable foundation materials for surface features for an outlet works and that would require additional evaluation, design, and foundation preparation or treatment (likely involving excavating the soil and replacing it with engineered fill, or requiring a new site location having better foundation materials) are fine-grained soils containing organic material and having low to medium compressibility (OL), as well as any fine-grained soils having high compressibility (MH, CH, OH, and PT).
- In terms of foundation permeability as it relates to internal erosion potential, the following should be considered [45]:
 - Seepage issues may exist for well to poorly graded gravels (GW, GP) and well to poorly graded sands (SW and SP), which are associated with high permeability.
 - Erodibility issues may exist for silty gravel (GM), silty sand (SM), and silts (ML), even at low gradients.

³⁵ The USCS is a soil classification system used in engineering and geology to describe the texture and grain size of a soil. The classification system can be applied to most unconsolidated material and is represented by a two-letter symbol, where the first letter is the soil type (such as G for gravel and C for clay), and the second letter is the gradation or plasticity (such as P for poorly graded and L for low plasticity). Therefore, SW would be a well-graded sand, and CH would be a clay of high plasticity.

It is important to evaluate these considerations and, if necessary, provide designed filters to reduce internal erosion potential. For filter design considerations, see Chapter 5, “Protective Filters,” of *Design Standards No. 13 – Embankment Dams* [46].

4.7.2 Foundation Design

4.7.2.1 Foundation Treatment

With the exception of including an outlet works as part of a concrete dam (i.e., the foundation is the dam, and there is a high level of control in terms of physical conditions and material properties), foundation treatment evaluation (of rock or soil foundations) is a very important aspect of the outlet works design and considerations and is described in the following sections. These considerations include:

- **Shaping.** See section 4.7.2.1.1 of this chapter.
- **Dental treatment.** See section 4.7.2.1.2 of this chapter.
- **Grouting.** See section 4.7.2.1.3 of this chapter.
- **Cleanup.** See section 4.7.2.1.4 of this chapter.
- **Anchors and cutoffs.** See section 4.7.2.1.5 of this chapter.

4.7.2.1.1 Shaping

The foundation should be shaped so that a uniformly varying profile is obtained that is free of sharp offsets or breaks [47].

- **For soil foundations,** all organic or other unsuitable materials, such as stumps, brush, sod, and large roots, should be stripped and wasted. Additionally, all pockets of soil significantly more compressible than the average foundation material should be removed and replaced with engineered fill. All irregularities, ruts, and washouts should be removed and replaced with engineered fill.
 - Unreinforced, undrained cut slopes should be flat enough to prevent sloughing. Cut slopes in soil should be determined for site-specific conditions. For reference, many of Reclamation’s excavated soil slopes have been in the range of 1½:1 to 2:1 (horizontal:vertical) or flatter. Note: Much flatter cut slopes (in the range of 4:1) are normally required when excavating through or adjacent to an embankment dam. The flatter cut slopes (referred to as transverse bonding slopes) are needed to ensure that the backfill around the outlet works can be effectively tied (compacted) into the existing embankment dam cut slopes.

**Design Standards No. 14: Appurtenant Structures for Dams
(Spillways and Outlet Works) Design Standards**

- Fine-grained (cohesive) soil foundations and engineered fill should be within 2-percent dry and 1-percent wet of the Proctor optimum moisture content and at least 95-percent Proctor density. Granular (cohesionless) soil should be compacted to at least 94-percent compaction using the vibratory hammer method³⁶ [48].
- Protection of a soil foundation may include leaving temporary cover of several feet of unexcavated material, or placing several feet of fill material, to address freezing concerns, as well as placing a 3- to 4-inch lean concrete pad or 2-inch shotcrete layer on the exposed foundation.
- **For rock foundations**, eliminate abrupt changes/breaks in the excavated profile. Also, faults or shear zones may be encountered during excavation, and the excavation of unsound rock produces depressions or shallow trenches that must be backfilled with concrete (see figure 4.7.2.1.1-1). General treatment guidelines for cavities, faults, shear zones, cracks, or seams [49] include:
 - For openings with widths (W) of 2 inches or less, clean to a depth (D) of three times the width of the opening and treat by filling with slush grout (for more details, see Section 4.7.2.1.2, “Dental Treatment,” of this chapter).
 - For openings with widths (W) greater than 2 inches and up to 5 feet, clean to a depth of three times the width of the opening or to a depth where the opening (O) is 0.5 inch wide or less, but usually not to a depth exceeding 5 feet, and treat by filling with dental concrete (for more details, see Section 4.7.2.1.2, “Dental Treatment,” of this chapter).
 - Openings with widths (W) greater than 5 feet constitute a special situation requiring the depth of cleaning and treatment to be determined in the field.

If shaping requires blasting, proper procedures are essential to ensure that the permeability and strength of the rock foundation are not adversely affected. See Chapter 6, “Structural Considerations for Spillways and Outlet Works,” of this design standard for blasting background and considerations.

³⁶ 94-percent compaction by the vibratory hammer testing replaces 70- to 80-percent density by relative density testing.

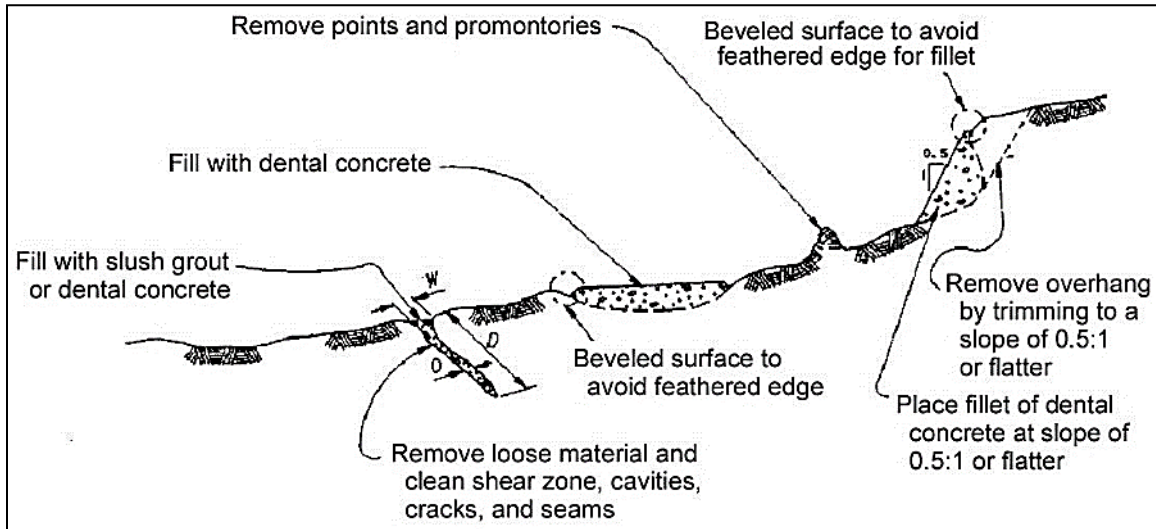

Figure 4.7.2.1.1-1. Cleaning and treatment of rock foundation [49].

Unreinforced, undrained cut slopes in rock may be determined on a case-by-case basis using local geologic conditions and/or reinforcement to design stable cut slopes (for reference, cut slopes typically range between $\frac{1}{4}$:1 and $\frac{1}{2}$:1).

Of note, rock foundations susceptible to air or water slaking (deterioration) and/or freezing should be protected until concrete placement for the outlet works begins. As with a soil foundation, protection of a rock foundation subject to slaking may include leaving temporary cover of several feet of unexcavated material or placing several feet of fill material to address freezing concerns, as well as placing a 3- to 4-inch, lean concrete pad or 2-inch shotcrete layer on the exposed foundation.

4.7.2.1.2 Dental Treatment

Exploratory drilling or final excavation associated with rock foundations may uncover faults, shear zones, seams, and shattered or inferior rock extending to depths that are not practical to remove [48]. These conditions require special treatment in the form of removing some of the material to depths as noted in Section 4.7.2.1.1, “Shaping,” of this chapter, and backfilling the excavation with cement grout or lean concrete. Two types of dental treatment are used:

- **Slush grout or joint mortar** is a neat cement grout (for cracks less than $\frac{1}{2}$ inch) or a sand-cement slurry (for cracks greater than $\frac{1}{2}$ inch) that is placed into foundation cracks. Cracks or joints are filled with grout, rather than spreading grout on the surface (see figure 4.7.2.1.2-1). Slush grout should be used to fill narrow surface cracks, not to cover areas of the foundation. To ensure adequate penetration of the crack, the maximum

Design Standards No. 14: Appurtenant Structures for Dams (Spillways and Outlet Works) Design Standards

particle size in the slush grout mixture should be not greater than one-third the crack width. The consistency of the slush grout mix may vary from a very thin mix to mortar as required to penetrate the crack. The water-cement ratio should be kept as low as possible to prevent shrinkage. Preferably, the grout should be mixed with a mechanical or centrifugal mixer, and the grout should be used within 30 minutes after mixing.

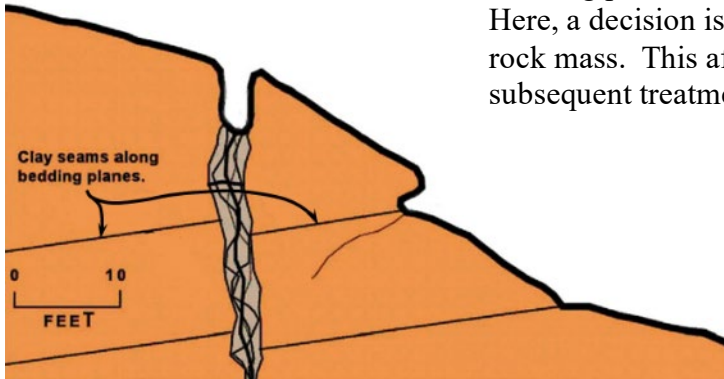

Figure 4.7.2.1.2-1. Slush grouting.

The type of cement required will depend on the concentration of sulfates in the foundation materials and ground water. Low-alkali cement is required for alkali-sensitive materials. Sand and water quality should be equal to that required for structural concrete. All cracks should be wetted before placing slush grout. Slush grout may be applied by brooming over surfaces containing closely spaced cracks or by troweling, pouring, rodding, or funneling into individual cracks [48].

- **Dental, leveling, shaping, or backfill concrete and concrete fillets** are used to fill or shape depressions, grooves, extensive areas of vertical or near vertical surfaces, and sawteeth (deep grooves) created by bedding planes, joints, and other irregularities such as previously cleaned out solution features, shear zones, large joints, or buried channels (see figure 4.7.2.1.2-2). Formed dental concrete can be used to fillet steep slopes and fill overhangs. It may be appropriate in local areas to place a concrete mat over a zone of closely spaced irregularities. Dental concrete shaping can be used, rather than removal by blasting, when excessive amounts of excavation would otherwise be required. Dental concrete slabs should have minimum thicknesses of 6 inches, depending on the quality of the foundation. Thin areas of dental concrete over rock projections on a jagged

Bedding planes may modify cleanup plans. Here, a decision is made to remove the rock mass. This affects the decision on the subsequent treatment.



Block is removed between fracture zone, bedding plane, and joints. Treatment to further shape the surface required dental concrete.

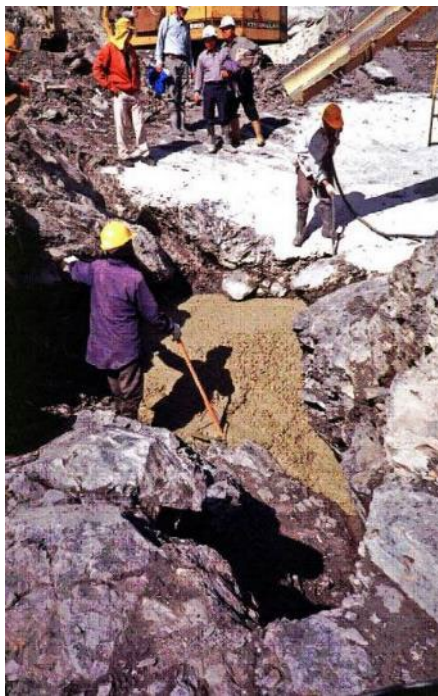
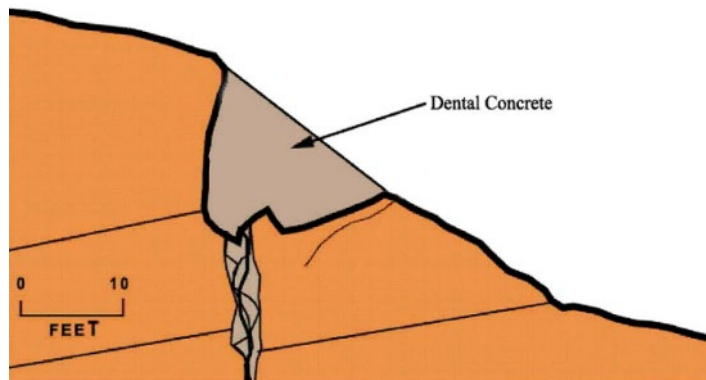

Treating foundation with dental concrete

Figure 4.7.2.1.2-2. Dental concrete.

**Design Standards No. 14: Appurtenant Structures for Dams
(Spillways and Outlet Works) Design Standards**

rock surface are likely to crack and should be avoided by using a sufficient thickness or limiting slab widths with joints. Feathering at the edges of concrete slabs shall not be permitted. To eliminate feathering, the edges of slabs shall be sloped no flatter than 45 degrees (see figure 4.7.2.1.2-3). When fillets of dental concrete are placed against vertical or near vertical surfaces, feathering on the edges shall not be permitted. Instead, a beveled surface with a minimum thickness of 6 inches will be required at the edges of the fillet (see figure 4.7.2.1.2-3).

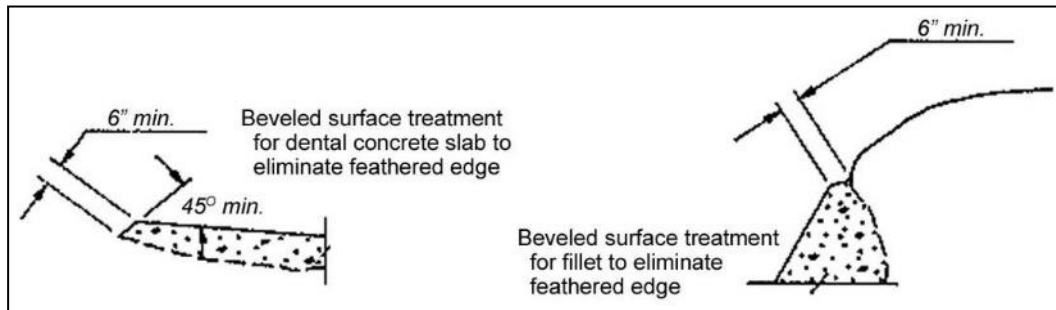

Figure 4.7.2.1.2-3. Beveled surfaces to eliminate feathered edges [49].

Concrete mix proportions should provide a minimum 28-day strength of 3,000 lb/in². The maximum size aggregate should be less than one-third of the minimum thickness of slabs or one-fifth of the narrowest dimension between the side of a form and the rock surfaces. The cement type will depend on the concentration of sulfates in the foundation materials and ground water. Low-alkali cement is required for alkali-reactive materials. Aggregate and water quality should be equal to that required in structural concrete.

The rock surface should be thoroughly cleaned and moistened before concrete is placed to enable a good bond between the concrete and rock foundation. When overhangs are filled with dental concrete, the concrete must be well bonded to the upper surface of the overhang. The overhang should be shaped to allow air to escape during concrete placement to prevent air pockets between the concrete and the upper surface of the overhang. The concrete must be formed and placed so that the top of the concrete is higher than the upper surface of the overhang, so that the pressure creates a tight contact. Grout pipes should be installed in the dental concrete to fill air voids where required. If grouting through dental concrete takes place, pressures should be closely controlled to prevent jacking the concrete or fracturing the overlying outlet works features. Dental concrete should have a roughened, broomed finish and be treated as a construction joint (CJ) for satisfactory bond with the overlying outlet works features. Dental concrete should be cured by water or an approved

curing compound for 7 days or be covered by the outlet works features. Placement of concrete features may not be permitted for a minimum of 72 hours to allow time to develop sufficient strength and limit cracking potential before loading the dental concrete [48].

4.7.2.1.3 Grouting

The principal objectives of grouting a rock foundation are to establish an effective seepage barrier and to consolidate the foundation [45]. With the exception of rock tunnel conveyance features, grouting is typically limited to the intake structure and portion of the conveyance feature that crosses grouting zones associated with the dam (such as a gate chamber or shaft). This section is only applicable to cement (not chemical) grout. Two types of grouting associated with outlet works surface features (control structures) are discussed below:

- **Consolidation or blanket grouting** is the low-pressure injection of cement grout into the foundation to fill voids, fracture zones, and cracks at and below the surface of the excavated foundation. The purpose of this grouting is to provide a firm foundation to support loads from the structure. It is done in rock foundations when rock jointing and/or fractures are such that significant foundation deformation could occur as a result of loads from the structure. The grout is intended to provide uniformity in the foundation. This is accomplished by drilling and grouting relatively shallow holes (for concrete dams, they are referred to as “B holes”). The extent of the area grouted and the depth of the holes should be dependent on local conditions; however, in general, the horizontal spacing of the grout holes is around 10 to 30-foot centers (spacing), and the depth of grout holes tends to be in the range of 10 to 20 feet. Site-specific conditions must be considered when establishing the grouting pressure; however, as a starting point, an approximate pressure is 1 pound per square inch per foot (lb/in²/ft) of depth, plus any water pressure. If the outlet works crosses grouting zones associated with the dam, grouting of this portion of the outlet works foundation may be a continuation of the grouting program for a dam [47].
- **Curtain grouting** is high-pressure injection of cement grout at depth into the foundation to control seepage. The intent of this grouting is to provide an impervious foundation barrier from abutment to abutment. The grout holes (for concrete dams, they are referred to as “A holes” when drilled from a foundation gallery, or referred to as “C holes” when drilled from the excavated or prepared surface) are typically located beneath portions of the conveyance features that cross grouting zones associated with a dam and are usually a single line of holes drilled on 10-foot centers (although multiple lines of grouting may be needed, and wider or closer spacing may be required due to site-specific conditions). The intent is to have spacing such that grout travel overlaps from adjacent holes. To minimize the potential for damaging the foundation, curtain grouting is

**Design Standards No. 14: Appurtenant Structures for Dams
(Spillways and Outlet Works) Design Standards**

normally undertaken after consolidation grouting. Although the depth of grout holes will be determined by site-specific conditions, general practice suggests hole depths of 30 to 40 percent of the maximum design hydrostatic head for a hard, dense foundation, and hole depths as much as 70 percent of the maximum design hydrostatic head for a poor foundation. Site-specific conditions must be considered when establishing the grouting pressure; however, as a starting point, an approximate pressure is 1 lb/in²/ft of depth, plus any water pressure. As with consolidation grouting, if the outlet works crosses grouting zones associated with the dam, grouting of this portion of the outlet works foundation may be a continuation of the grouting program for a dam [47].

Two grouting applications, mostly associated with excavated tunnels in rock, are discussed in the following paragraphs:

- **Backfill grouting** is used to fill any voids between a structural feature, such as the outside limit of a reinforced concrete placement, and the excavated limits of the surrounding rock foundation. Application of backfill grouting focuses on areas where gravity and concrete shrinkage tend to create voids, such as near the crown (top) of a tunnel liner. Backfill grouting should not occur until the concrete feature (such as a tunnel liner) has achieved its design (compressive) strength (such as 4,500 lb/in² at 28 days). Low pressures are used, which are in the range of 15 to 30 lb/in², plus any water pressure (see figure 4.7.2.1.3-1 for more details).
- **Ring or pressure grouting** is similar to consolidation grouting where the intent is to inject low-pressure cement into the surrounding tunnel foundation to fill voids, fracture zones, and cracks within at least 20 to 25 feet of the excavation limits of the tunnel. The ring grout line (i.e., multiple grout holes around the perimeter of the tunnel at a given location or station along the tunnel) along the tunnel is typically spaced at 20-foot centers. Location and number of grout holes in a ring grout line are site specific, but they tend to be spaced between 45 and 90 degrees around the perimeter of the tunnel. It is common for a ring grout line to be offset (rotated) 45 degrees from the previous and subsequent ring grout line. Also, drilling grout holes and pressure grouting will not be initiated until backfill grouting has been completed within approximately 100 feet upstream and downstream from the ring grout line location (see figure 4.7.2.1.3-2 for more details). It should be noted that, depending on foundation conditions, ring grouting may be replaced with backfill (crown) grouting combined with weep (drainage) holes (see Section 4.7.3.1, “Drainage,” for more details) for tunnel sections downstream from the dam foundation grouting.

Chapter 4: General Outlet Works Design Considerations

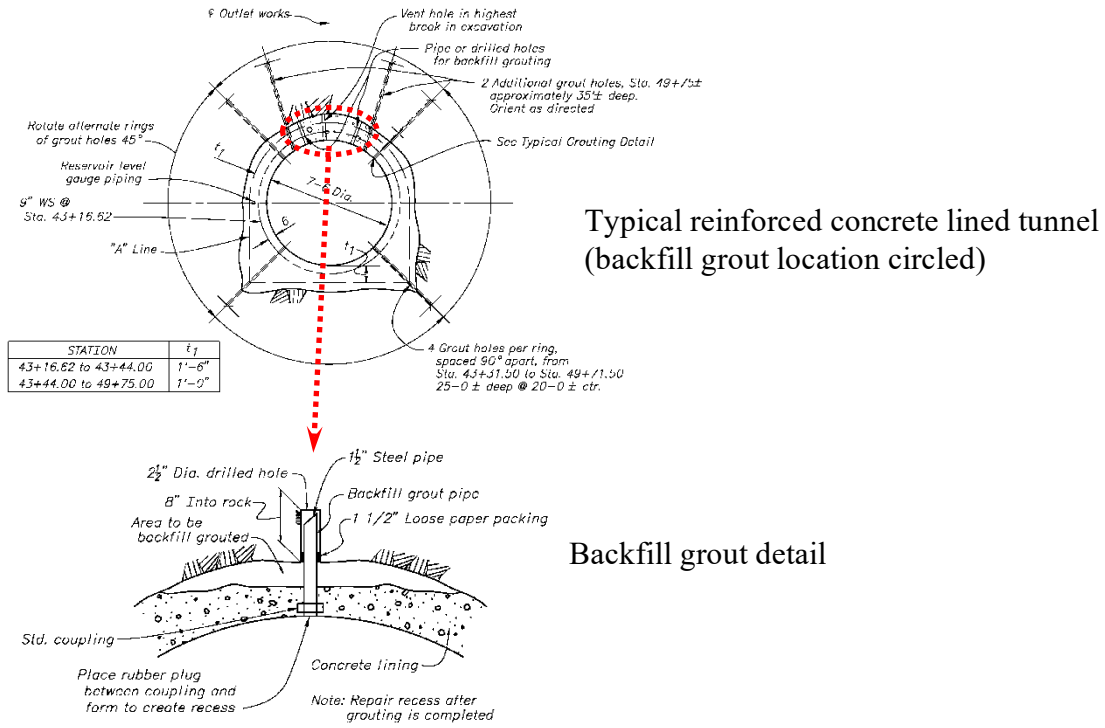

Figure 4.7.2.1.3-1. Backfill grouting.

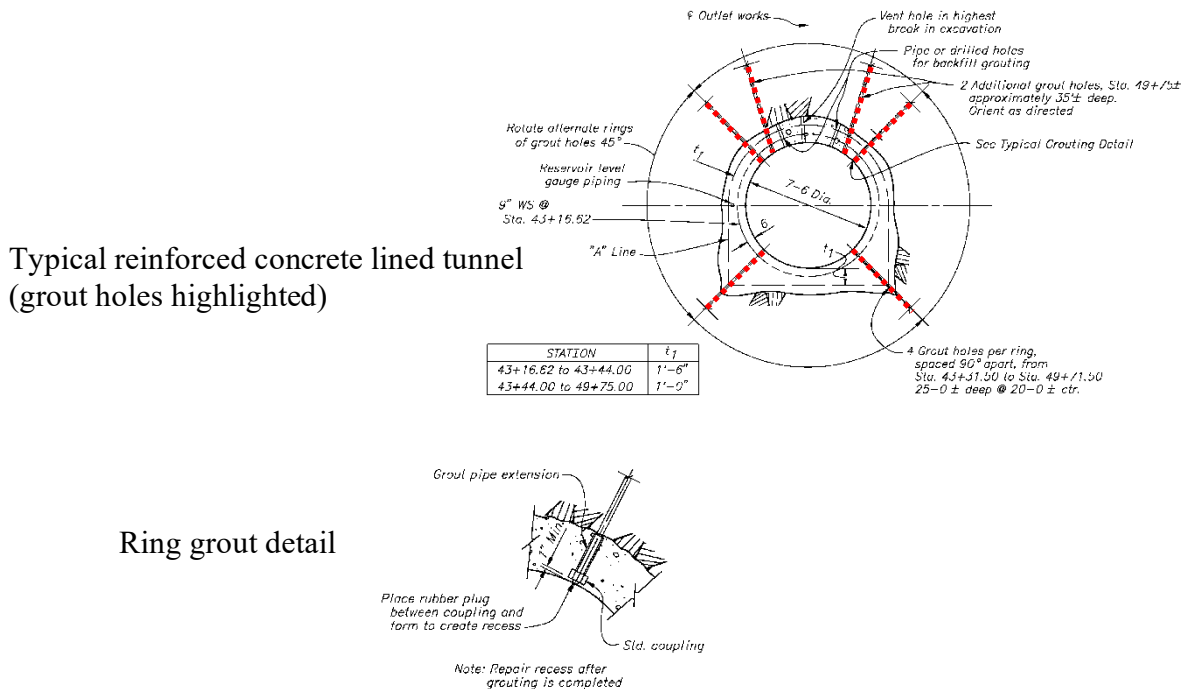

Figure 4.7.2.1.3-2. Ring or pressure grouting.

Design Standards No. 14: Appurtenant Structures for Dams (Spillways and Outlet Works) Design Standards

4.7.2.1.4 Cleanup

Foundation cleanup can be labor intensive and costly, but it must not be neglected. Proper cleanup of a foundation before concrete placement increases the likelihood that the contact area will meet design intent in terms of the compressive and shear strength, along with permeability. Poor foundation cleanup can result in reduced bonding, and compressive and shear strengths, leading to weak zones and providing a permeable path for seepage [48]. To ensure proper cleanup of a foundation, both cleaning and water removal need to be fully addressed.

- Cleaning rock foundations includes barring and prying loose any drummy³⁷ rock, using an air/water jet to remove as much loose material as possible, and removing (by hand) loose material that an air/water jet misses. Cleaning soil foundations should include removing loose or disturbed materials missed by machine excavation that will not be suitable foundation even after compaction (if needed) [48].
- Water in small quantities can be removed from a rock foundation by vacuuming (with a shop-vac or air-power venturi pipe) or other approved methods. Large water quantities from seeps can be isolated, and gravel sumps can be constructed, pumped, and subsequently grouted. Another approach for both rock and soil foundations is using well points, which can temporarily stop the seeps and/or lower the ground water several feet below the foundation contact, allowing placement of the concrete [48]. It should be noted that, in some cases, it may be necessary to install well points before beginning excavation. Finally, the rock foundation should be washed or wetted before placing concrete to achieve a saturated surface dry (SSD)³⁸ condition.

4.7.2.1.5 Anchors and Cutoffs

Anchors and cutoffs are important design considerations that should not be overlooked. These features are used to further stabilize the outlet works and foundation.

- **Anchors.** These features could include anchor bars, rock bolts, and post-tensioned anchors and are usually associated with a rock foundation (there are some limited applications using soil anchors or soil nails, but this is the exception, not the rule, for stabilizing the outlet works and soil foundation).

³⁷ Drummy rock is associated with a foundation that has delaminated or separated layers or blocks.

³⁸ SSD condition is achieved when the foundation surface pores are saturated, and free surface water and puddles have been removed from the surface of the foundation. This is the optimal time to place new concrete on the foundation surface.

Chapter 4: General Outlet Works Design Considerations

- **Anchor bars.** The most common anchor with the least tensile capacity is the anchor bar, which is primarily used to stabilize outlet works surface features, such as control structure, conveyance feature, and terminal structure floors and, in some cases, walls (most Reclamation outlet works surface features with rock foundations include anchor bars as a design detail). Anchor bars are a passive anchoring system designed to provide adequate factors of safety for stability. The anchor bars are typically spaced in a 5- to 10-foot grid pattern, which is governed by the floor or wall dimensions between joints. Anchor bar sizes typically range from No. 8 to No. 11 reinforcing bars. Anchor bars are placed in drilled foundation holes and cement grouted in place with a portion of the anchor bar equal to embedment length extending out of the foundation (standard hook length as noted by standard drawings 40-D-60003 and 40-D-60004 and/or the current American Concrete Institute [ACI] code if floor or wall thickness is not sufficient to contain embedment length without bending). This embedment length will be encased in the reinforced concrete floor or wall (see figure 4.7.2.1.5-1 for more details).
- **Rock bolts.** The grouted rock bolt is a less frequently used anchor with more tensile capacity than the anchor bar. Rock bolts are extensively used to stabilize outlet works excavated surfaces (such as Reclamation's Ridges Basin Dam outlet works). On occasion, grouted rock bolts are also used to stabilize steep rock excavation in outlet works intake structures, chutes, and terminal structures. Rock bolts provide active compressive forces within the rock mass, but they are generally treated as passive anchors within the concrete. Spacing and size of rock bolts are based on site-specific analysis/design results (see figure 4.7.2.1.5-2 for more details).
- **Post-tensioned anchors.** The least used anchor with the greatest tensile capacity (compared to the anchor bar and rock bolt) is the post-tensioned anchor. Reclamation's experience with post-tensioned anchors associated with outlet works is limited. Some nonoutlet works applications have addressed concrete dam stability issues (such as Reclamation's Stewart Mountain Dam and Minidoka Dam). These anchors generally provide active resistance to loads. This is accomplished by anchoring through concrete into the rock foundation. Tensioning provides compression across the foundation (concrete-rock) contact. Design procedures are based on the Post-Tensioning Institute's *Recommendation for Prestressed Rock and Soil Anchors* [50].

**Design Standards No. 14: Appurtenant Structures for Dams
(Spillways and Outlet Works) Design Standards**

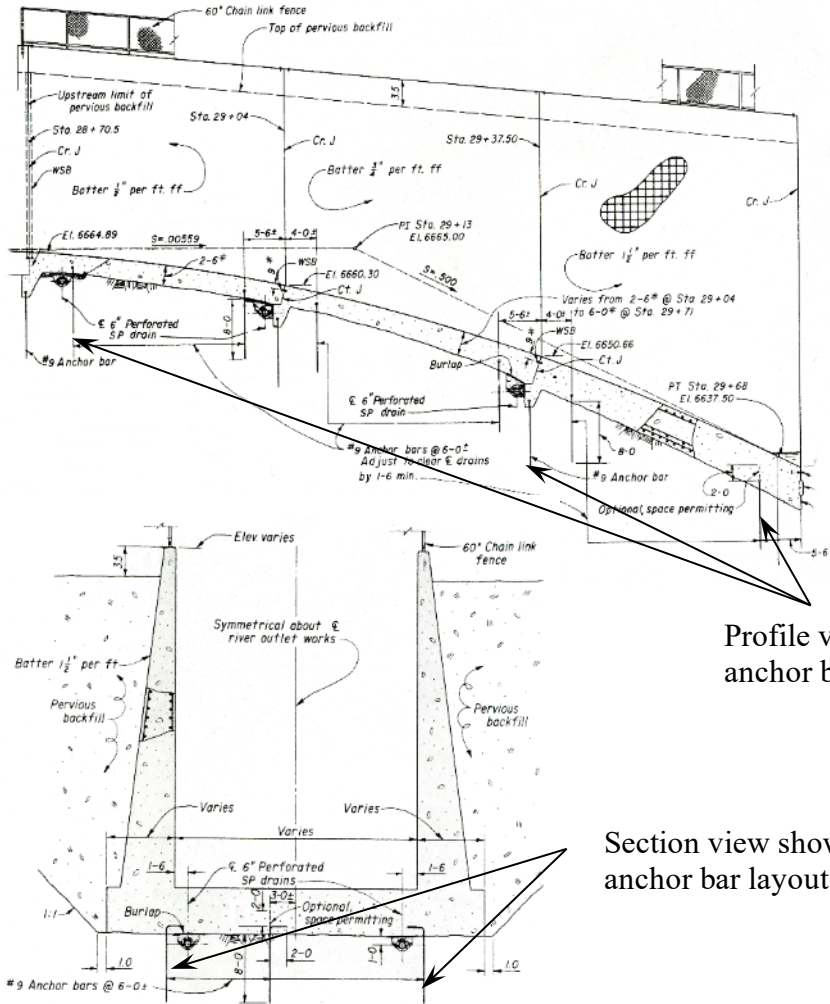

Profile view showing anchor bar layout.

Section view showing anchor bar layout.

Anchor bars



Constructing new outlet works. Note anchor bars installed through mud slab into foundation associated with outlet works chute.

Figure 4.7.2.1.5-1. Anchor bars.

Chapter 4: General Outlet Works Design Considerations

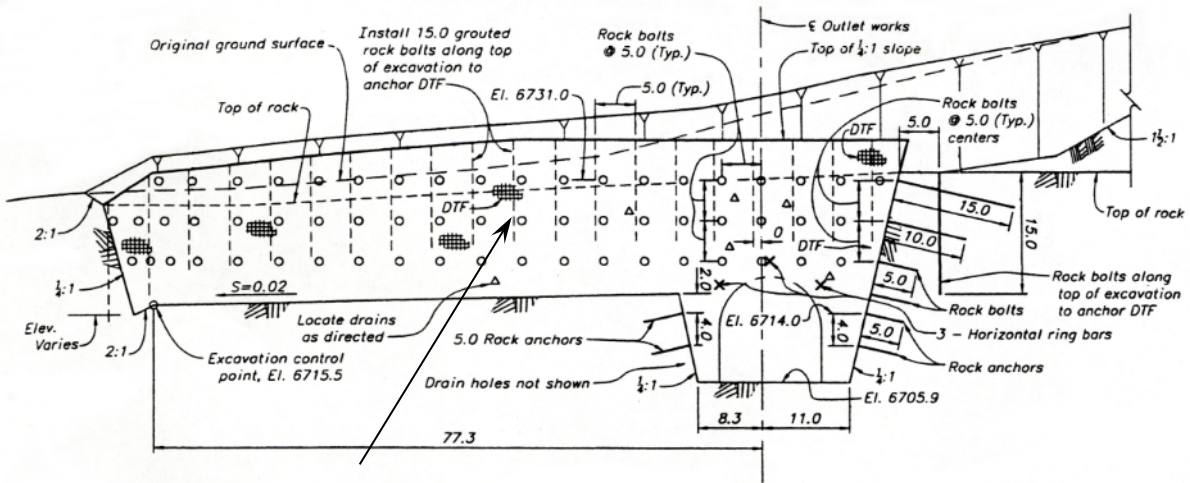

Profile view of rock slope excavation and rock bolts layout at the downstream outlet works portal.



Control house containing regulating gates.

Rock bolts securing wire mesh on outlet works downstream portal excavated slope.

Constructing new multipurpose river outlet works.



Figure 4.7.2.1.5-2. Rock bolts.

**Design Standards No. 14: Appurtenant Structures for Dams
(Spillways and Outlet Works) Design Standards**

Cutoffs. These features could include reinforced concrete keys, secant piles, and soil cement, or RCC diaphragm walls, and they are associated with both rock and soil foundations. Along with addressing stability needs, cutoffs could affect seepage potential. The most common cutoff is the reinforced concrete key, which is primarily used to reduce seepage and/or increase stability to the outlet works surface features such as chute and terminal structure floors. For more details, see Chapter 3, “General Spillway Design Considerations,” of this design standard.

4.7.2.2 Foundation Acceptance

During the design, it is very important to clearly define what is, and is not, an acceptable (adequate) foundation, which will help establish the foundation inspection and approval process aimed at ensuring that design intent is being met during construction, as described in the following sections. These sections include:

- **Foundation inspection and acceptance procedures.** See section 4.7.2.2.1 in this chapter.
- **Critical foundation areas.** See section 4.7.2.2.2 in this chapter.
- **Documentation.** See section 4.7.2.2.3 in this chapter.

4.7.2.2.1 Foundation Inspection and Acceptance Procedures

As part of the design for a modified or new outlet works, foundation inspection and acceptance procedures should be developed. This first requires a definition of what is an acceptable foundation, versus an unacceptable foundation, for the outlet works feature. Once this has been clarified, the following should be included in the development of the inspection and acceptance procedures:

- Consider treatment measures where an inadequate foundation is identified.
- Apply protective measures to ensure the integrity of an adequate foundation once it has been prepared and prior to placing the outlet works feature on the foundation.
- Develop procedures to be used when inspection and approval are made onsite by the designer of record, geologist, and field personnel.
- Develop procedures to be used when inspection is made by field personnel and approval is made via telephone by the designer of record.
- Identify appropriate field testing to be conducted prior to or during the foundation inspection and approval.
- Prepare a foundation inspection checklist, which should be completed during all foundation inspections and approvals.

Chapter 4: General Outlet Works Design Considerations

- Provide adequate documentation of foundation conditions, including geologic mapping and photographs of the foundation area being inspected. Sufficient detail should be provided so that future problems, should they develop, can be understood based on the documentation.

For more details, see Chapter 6, “Structural Considerations for Spillways and Outlet Works,” of this design standard.

4.7.2.2.2 Critical Foundation Areas

Identify critical and noncritical foundation areas and how they will be inspected and approved. There are several considerations used to identify critical and noncritical foundation areas including:

- Critical foundation areas are typically associated with significant loading and settlement/deformation potential, significant seepage potential, and/or tied to PFMs. Typical outlet works features associated with critical foundation areas include intake structures, conveyance features, and terminal structures. Noncritical foundation areas would be the remainder of the outlet works foundation areas not identified as critical.
- Critical foundation areas may also include areas that have not had an initial inspection or areas that previously have been inspected and approved but are now exhibiting differing foundation conditions than at the time of previous approval. Noncritical foundation areas are typically areas exhibiting similar conditions to those that have already been inspected and approved.

For critical areas, an onsite foundation inspection and approval should be planned and involve the designer of record and geologist. For noncritical areas, an onsite inspection and approval process will typically be carried out by the field personnel, who must be aware of, and able to identify, dissimilar, irregular, or unusual conditions that would require additional followup and evaluation (such as the same level of onsite inspection and approval required for critical foundation areas). For more details, see Chapter 6, “Structural Considerations for Spillways and Outlet Works,” of this design standard.

4.7.2.2.3 Documentation

A DM will be prepared for each foundation inspection. A draft DM should be prepared by the designer of record before the foundation inspection and approval, when the designer of record is directly involved (onsite). A draft DM should be prepared by field personnel before the foundation inspection and approval, when the designer of record is not directly involved (telephone approval). This draft DM should be provided to the designer of record prior to the telephone approval. With few exceptions, the DM for both cases should be finalized and signed within 7 working days following the foundation inspection. However, it is recognized that there will be circumstances when the DM cannot be finalized within this time period. When this occurs, the designer of record will coordinate with other

Design Standards No. 14: Appurtenant Structures for Dams (Spillways and Outlet Works) Design Standards

involved parties to identify a timely and mutually agreed to completion date. See Chapter 6, “Structural Considerations for Spillways and Outlet Works,” of this design standard for more details on the contents of a DM and an example of a DM.

4.7.3 Drainage and Insulation

Both drainage and insulation are important considerations that should be fully evaluated during the design of modified and new outlet works. Inadequate or inappropriate drainage and insulation designs can lead to significant damage and/or failure of outlet works features.

4.7.3.1 Drainage

Drains beneath and/or adjacent to appurtenant structures should be provided to control excessive water pressure, which might lead to instability, including failure of the outlet works feature or its foundation. Even a minor amount of ground water can result in structural damage if it is not drained freely and is allowed to build up pressure, or if it can cause frost heave during freezing temperatures. Historically, it has been Reclamation’s practice to design appurtenant structures to withstand part or all of the anticipated water pressure (i.e., assuming drains are not functioning or are only partially effective). It has been (and is considered prudent) engineering practice to provide drainage to critical appurtenant structures (i.e., an appurtenant structure is considered critical if increased risk to the dam and/or downstream consequences could result from an inability to operate and/or failure). As cited in detail in *Frost Action in Soil Foundations and Control of Surface Structure Heaving Report* [51] and *Drainage for Dams and Associated Structures* [52], the following considerations should be included:

- Locations of drainage features should be limited to downstream outlet works feature (i.e., drainage associated with the conveyance features and terminal structure) and isolated from the reservoir. For more information concerning these drainage features, see figures 4.7.3.1-1 and 4.7.3.1-2. Also, see Section 4.8.6.1.2, “Contraction Joints,” and Section 4.8.6.1.3, “Control Joints,” in this chapter.
- Minimize disturbance of the foundation, particularly for rock foundations. For more information concerning these drainage features, see Section 3.7.3.1, “Drainage,” in Chapter 3, “General Spillway Design Considerations,” of this design standard. Also, see Sections 4.8.6.1.2, “Contraction Joints” and 4.8.6.1.3, “Control Joints,” in this chapter.
- Drain access and cleanout capabilities should be included in drainage features. For more information concerning drain access and cleanout features, see Chapter 3, “General Spillway Design Considerations,” of this design standard.

Chapter 4: General Outlet Works Design Considerations

- For outlet works surface features (such as chute conveyance features and terminal structures), drainage systems are typically laid out in a grid pattern with spacing of the grid in both the longitudinal (upstream-downstream) and transverse (lateral or cross-canyon) direction, and they are influenced by expected flow and loss of drainage efficiency over time. Typically, transverse drain spacing is the same as the floor slab joint spacing. Longitudinal collector drains can be located at the outside edges when the outlet works feature (such as a chute) is less than 30 feet wide. When the outlet works feature is 30 feet wide or greater, intermediate longitudinal collector drains spaced between the edge longitudinal collector drains should be considered [52].
- For outlet works subsurface features (such as conduit and tunnel conveyance features), the following should be considered:
 - Filter requirements can influence type, size, and location of the drainage system. Detailed guidance can be found in Chapter 5, “Protective Filters,” of *Design Standards No. 13 - Embankment Dams* [46]. Of note, for outlet works through embankment dams, zoned filters are normally required to encase the downstream end of the conduit conveyance feature (see figure 4.7.3.1-1).
- For outlet works tunnel conveyance features, drainage and/or weep holes are often provided in nonpressurized (free flow) tunnels to relieve external pressure caused by seepage along the outside of the tunnel lining. Weep holes typically extend through the lining and just into the surrounding foundation. Their main purpose is to reduce the external hydrostatic pressure on the tunnel lining. Drainage holes extend further into the foundation to provide additional drainage of the foundation surrounding the tunnel. Drainage and weep holes should normally be located above the anticipated maximum water surface in the tunnel. For a nonpressurized tunnel conveying a pressurized pipe, drainage and weep holes can be located anywhere above the tunnel floor (see figure 4.7.3.1-2). The drainage holes are commonly spaced at about 20-foot centers in the upstream-downstream direction, at intermediate locations between the ring grout holes (for more details, see Section 4.7.2.1.3, “Grouting,” in this chapter). Drainage and weep holes are typically located using embedded pipe inserts through the concrete liner and are drilled after the concrete has set. To avoid cutting the reinforcing bars, drilling holes directly through the concrete should be prohibited. Also, holes should not be drilled until backfill and ring grouting have been completed at least 150 feet from the holes.
- For outlet works tunnel conveyance features, drainage holes may be needed around the downstream tunnel portal to relieve external pressure caused by ground water conditions.

**Design Standards No. 14: Appurtenant Structures for Dams
(Spillways and Outlet Works) Design Standards**

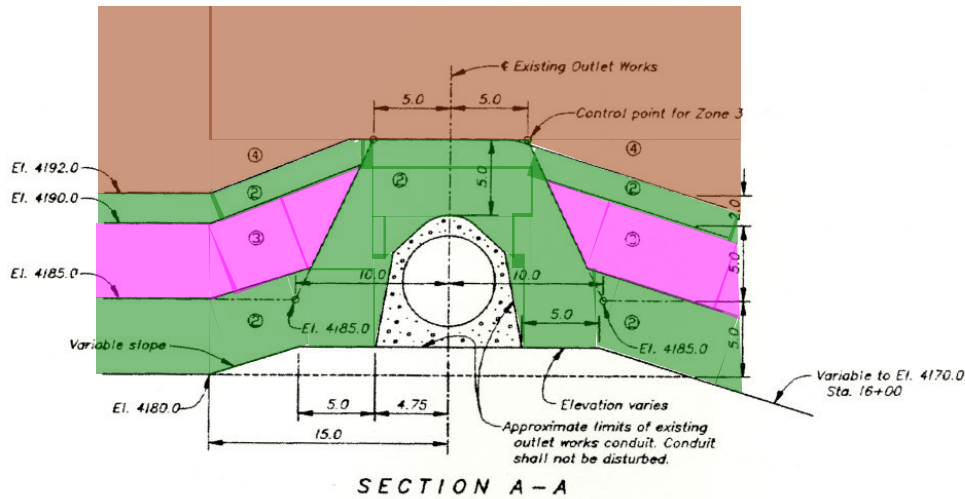

Outlet works: Drainage plan, sections and detail (downstream conduit extending through embankment dam)

Embankment Filter Encasing D/S Portion of Existing Outlet Works Conduit:

Zone 2 (sand)

Zone 3 (gravel)

Zone 4 (random fill)

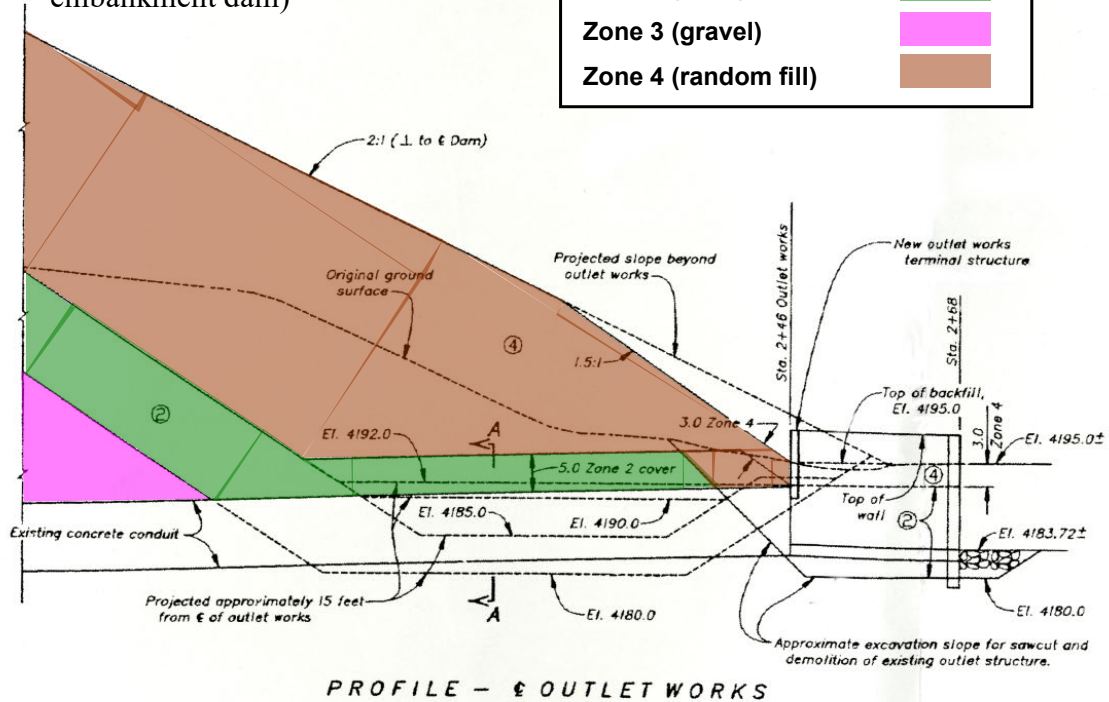
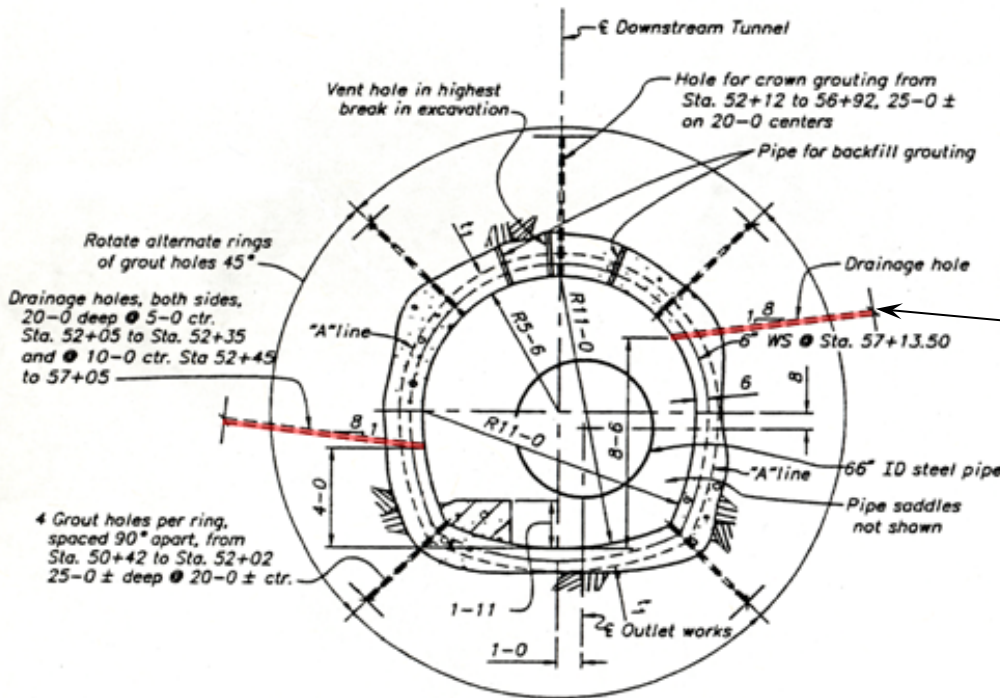

Figure 4.7.3.1-1. Drainage – zoned filter encasing downstream conduit section.

Chapter 4: General Outlet Works Design Considerations



Note: Right side drain hole is raised above the carrier pipe to facilitate access for cleaning and to make more visible from walkway.

Figure 4.7.3.1-2. Drainage – drainage holes in downstream tunnel.

- Consideration should be given to mitigating contamination potential from adjacent concrete placement during construction. Historically, this has been accomplished with insulation material, burlap, geotextiles, geomembranes, and/or steel wool (within weep holes) as a barrier between drains (including pervious material placed around a drain pipe) and fresh concrete.
- Particularly for appurtenant structures (such as spillways and outlet works) associated with high-velocity, high-volume releases, care must be taken so that the drainage system is not subjected to adverse hydraulics, which can damage or fail the appurtenant structure. Two conditions that should be evaluated include: (1) excessive back pressure, which could introduce hydrostatic (uplift) pressure beneath an outlet works chute and/or terminal structures; and (2) stagnation pressure that could be introduced through cracks and/or open joints, leading to pressurizing the drainage system [52]. In other words, there should generally be no direct path (such as drains, open joints, or cracks) through floor slabs and walls that are subject to high-velocity, high-volume flow conditions.
- Air demand must be considered, which could be associated with providing a “vacuum break” to allow air to eliminate lowered pressures induced by high-velocity flow across drain outlets (see figure 4.7.3.1-3). Inlets or intakes which provide the air should be located above the maximum tailwater level.

**Design Standards No. 14: Appurtenant Structures for Dams
(Spillways and Outlet Works) Design Standards**

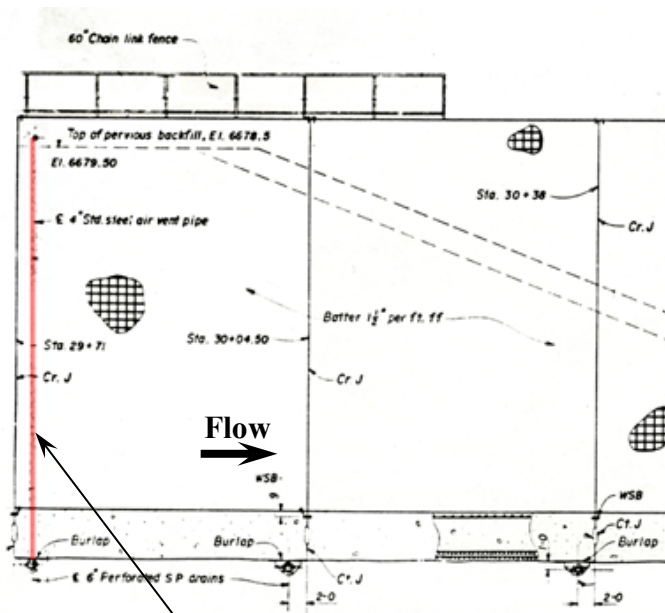

River outlet works stilling basin sections showing the (vacuum-break) vent pipes for the underdrain system

Outlet works chute and stilling basin section showing the (air demand) eductors or aspirators that may be needed when high-velocity flow moves across drain outlets. For more information, refer to *Drainage for Dams and Associated Structures* [52]

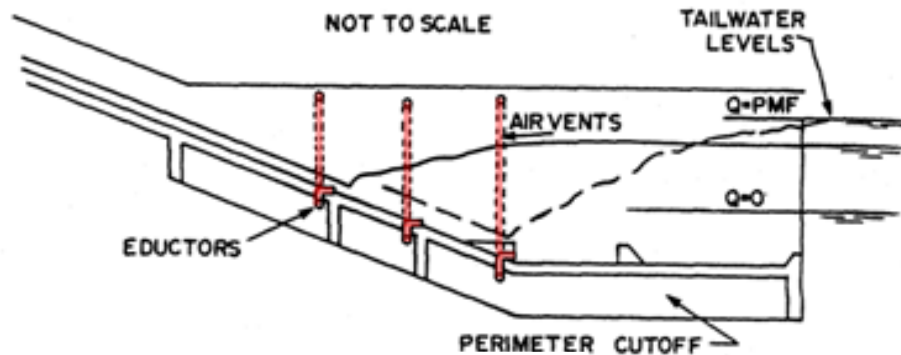
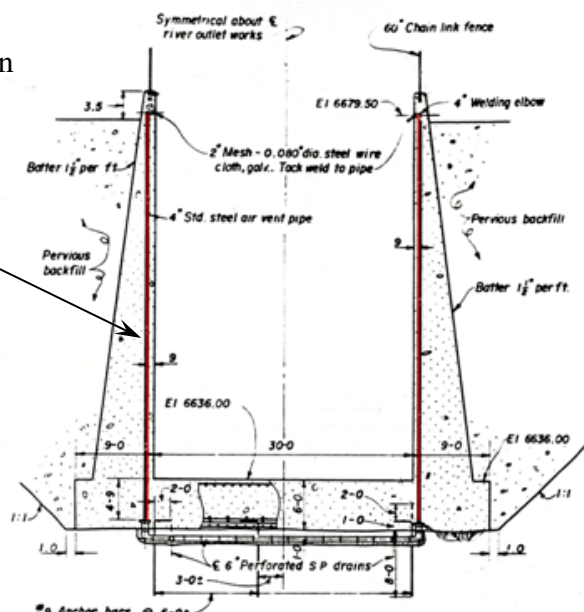

Figure 4.7.3.1-3. Air supply/demand.

4.7.3.2 Insulation

Considerable damage and/or failure can result from freezing foundations and adjacent materials. Unheated appurtenant structure surfaces in contact with frost-susceptible backfill or foundation exposed to water are subject to frost penetration, ice lenses, and subsequent loading (frost heave) that can be significant. For outlet works, insulation needs would typically be limited to exposed (surface) features, such as chute conveyance features and terminal structures. To address this concern, insulation requirements are employed to protect drainage systems associated with concrete slabs and walls.

Typical insulation materials include rigid polystyrene insulating materials. For more details, see Chapter 3, “General Spillway Design Considerations,” of this design standard. Also, refer to *Frost Action in Soil Foundations and Control of Surface Structure Heaving* [51] and *Drainage for Dams and Associated Structures* [52].

4.8 General Structural Considerations

This section provides general structural considerations for determining the type, location, and size of a modified or new outlet works. Detailed structural analysis and design can be found in Chapter 6, “Structural Considerations for Spillways and Outlet Works,” of this design standard.

As previously noted, unless specified otherwise, this chapter is applicable to the evaluation, analysis, and design of reinforced concrete for high-velocity and high-flow outlet works. Also, it should be noted that although national building codes are applicable and establish minimum structural design requirements, quantitative risk analysis methodology must be considered for design of hydraulic structures. As a result, design requirements for outlet works will generally equal or exceed national building code requirements. It should also be stressed that quantitative risk analysis methodology should never be used to reduce established codes, standards, and/or criteria. In addition, serviceability requirements, such as the need to limit cracking of structural concrete for hydraulic structures, are a key consideration for modification designs for existing outlet works and designs for new outlet works.

This section includes references to ACI Codes 318 and 350, along with Reclamation standard drawings based on the codes. As new versions of the design codes are issued, Reclamation reviews the codes and revises or replaces the applicable standard drawings (40-D-60003 and 40-D-60004). After the revisions to the standard drawings are approved, Reclamation issues a memorandum formally adopting the codes for use in future designs. Designers are responsible for using the current adopted versions of the design codes.

4.8.1 Loading Conditions

The following discussion summarizes typical loading conditions for designing a new outlet works or modifying an existing outlet works.

The more typical loading conditions discussed below will address most outlet works designs. However, there could be unique loading conditions associated with a given site and/or operations of an outlet works, which should be included with these more typical loading conditions:

- **Reservoir and tailwater loads.** The normal reservoir load is associated with the maximum normal RWS (either the top of active conservation or the top of joint use storage, whichever is higher). The maximum reservoir load is associated with the maximum flood-induced RWS. The tailwater load may be associated with either the minimum or maximum downstream water surface expected to occur with a given RWS. For usual, unusual, and extreme loading combinations associated with stability evaluation, see Section 4.8.3, “Stability Design,” in this chapter. For structural design methods, see Section 4.8.4, “Reinforced Concrete Design,” in this chapter.
- **Temperature loads.** Temperature-induced loads result from variations of concrete temperatures with the “stress free” temperature, which is typically associated with the initial set (hardening) of the concrete. To estimate temperature loads, the initial set is assumed to occur at the maximum heat of hydration temperature (occurring in the range of 2 to 6 days after concrete placement). The stress free temperature is the sum of the placement temperature and the maximum heat of hydration temperature. As an example, for a concrete placement temperature of 60 °F and a maximum heat of hydration temperature of 30 °F, the stress free temperature would be 90 °F. Without artificial cooling, the concrete could require several weeks to multiple months before it reaches a stable annual heating and cooling cycle. Concrete temperatures greater than the stress free temperature will result in expansion of the concrete, while temperatures less than the stress free temperature will result in contraction of the concrete. Particularly near the concrete surface, concrete temperature can vary greatly due to air temperatures and radiant heat. As an example, at some locations, it is common for temperatures to range from considerably below 0 °F to over 130 °F. Figure 4.8.1-1 illustrates a possible concrete temperature curve for the initial period after placement, temperature ranges the concrete may experience over time, and the potential impacts. This potentially large variation from the stress free temperature can lead to tensile stress cracking due to contraction (typically hair-line surface cracks some distance away from joints) and compression cracking due to expansion (typically spalling and/or delamination near joints). It should also be noted that adjacent concrete placements may not have the same stress free temperature.

Concrete Temperature History (Example) Evaluation of Joint Spacing and Cracking Potential for Concrete Slabs and Walls

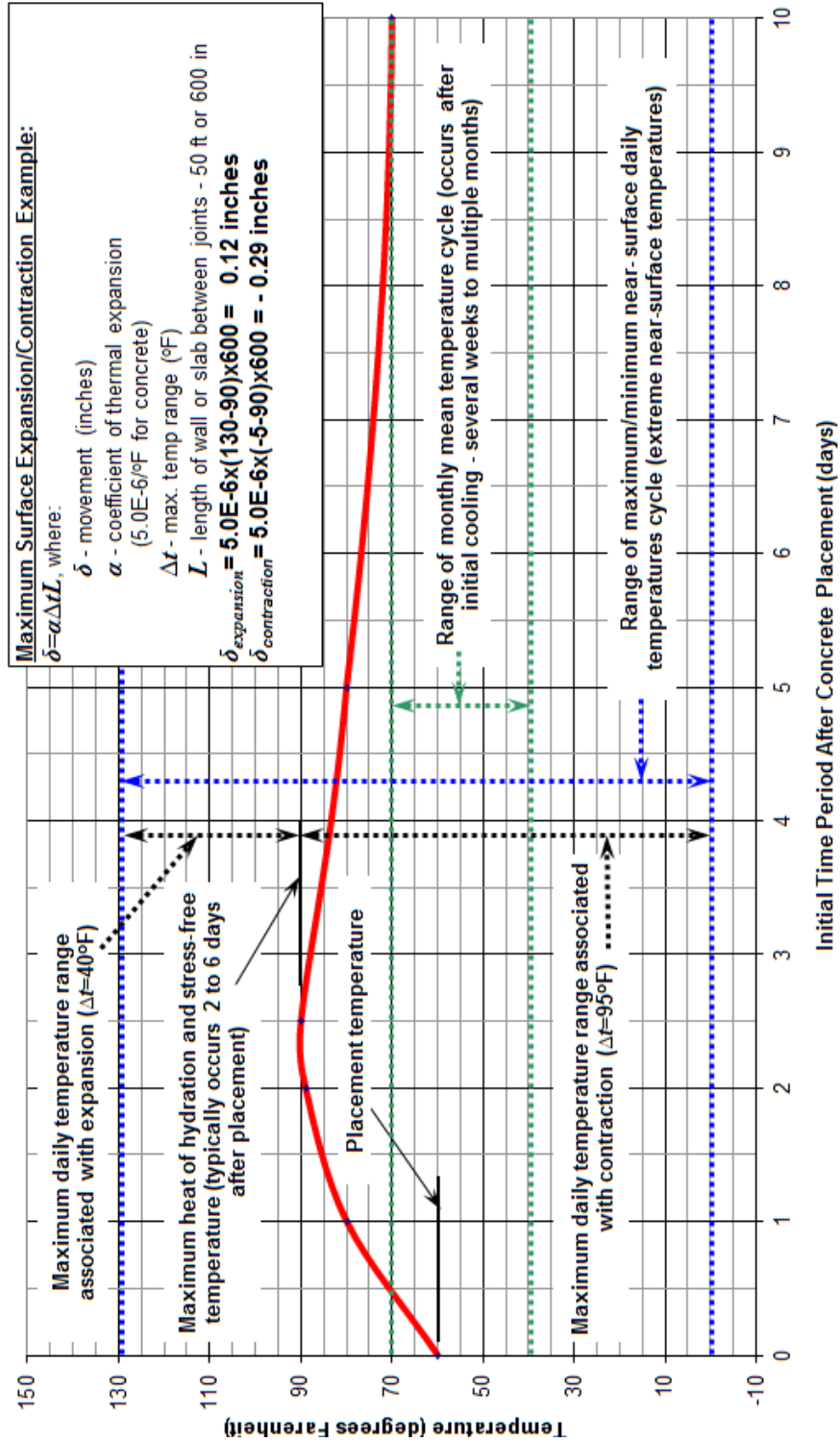

Figure 4.8.1-1. Concrete temperature history.

**Design Standards No. 14: Appurtenant Structures for Dams
(Spillways and Outlet Works) Design Standards**

Of note is the current industry practice of grinding cement much finer than in the past, which increases the potential for higher concrete temperatures, along with increased and/or more rapid strength gains during the curing process. Because of this practice, it is very important to fully evaluate and develop concrete mix designs that will meet the design intent, along with actions needed to accommodate high temperatures during the curing process and associated cracking potential. Finally, it should be noted that current (new) concrete materials are not necessarily compatible with older (existing) concrete, and care must be taken when designing modifications to existing concrete structures.

Unless a site-specific temperature study is undertaken, temperature loads are handled by requiring that temperature reinforcement be provided in hydraulic structures, where minimum temperature reinforcement should be based on requirements of ACI 350 [53] and a minimum of No. 6 bars at 1-foot spacing, each way, each face [47]. For other (above ground) structures, the requirements of section 7.12 of ACI 318 [54] may be appropriate. An area equivalent to No. 9 bars at 1-foot spacing, each way, each face, should be considered a maximum for temperature reinforcement unless supported by more detailed structural analysis. Also, details are incorporated into floor slab joint design to address large near-surface temperature variations (for more details, see Section 4.8.6, “Joints, Waterstops, and Tolerances,” in this chapter). For additional discussion of temperature reinforcement, see Chapter 6, “Structural Considerations for Spillways and Outlet Works,” of this design standard.

- **Uplift loads.** The normal uplift load (in the foundation) and/or external hydrostatic pressure are associated with the phreatic line,³⁹ which varies between the maximum normal RWS (either the top of active conservation or the top of joint use storage, whichever is higher) and the associated minimum tailwater surface expected to occur with the RWS. The maximum uplift load and/or external hydrostatic pressure are associated with the phreatic line, which varies between the maximum flood-induced RWS and the minimum tailwater surface [47]. An exception to assuming minimum tailwater conditions during a flood event would be using a hydraulic jump stilling basin that has the critical location at the upstream end of the stilling basin. This location is associated with minimum flow depth (d_1) before the hydraulic jump and the uplift equal to the full tailwater depth (equal to or greater than d_2) after the hydraulic jump. Flow-net analysis may be needed to estimate uplift loads. For usual, unusual, and extreme loading combinations associated with stability evaluation, see Section 4.8.3, “Stability Design,” in this chapter. For structural design methods, see Section 4.8.4, “Reinforced Concrete Design,” in this chapter.

³⁹ Phreatic line is the free surface of water seeping at atmospheric pressure through soil or rock.

- **Dead loads.** The dead load is equal to the weight of the outlet works concrete and any mechanical features. If no site-specific data are available, the unit weight of concrete (γ_c) can be assumed to equal 150 lb/ft³. Also, when applicable, the dead load will include earthfill (soil) and water loads. If no site-specific data are available, the unit weight of 120 lb/ft³ for pervious backfill, 130 lb/ft³ for embankment material (dry soil), and 135 lb/ft³ for saturated soil can be used as default values.
- **Ice loads.** The ice load (in the reservoir or tailwater) is based on site-specific data. If site-specific data are not available, procedures found in the *Report of the Task Committee on Design Criteria for Concrete Retaining Walls* [55] can be used to estimate ice loads. A default acceptable estimate of ice load is 10,000 pounds per linear foot (lb/lf) of contact between the ice and structure for an assumed depth of 2 feet or more when basic data are not available [47]. Ice loads due to the freezing of standing water are typically limited to outlet works features exposed to the reservoir or tailwater. Ice loads (in the form of dead weight) can also be caused by ice accumulation on a structure from operations or seepage during freezing conditions. Depending on site-specific conditions, several feet of ice can form on a structure. The potential for ice accumulation may affect the type of gate or valve and/or the type of energy dissipation structure selected. For example, a free discharging outlet works may produce a lot of spray that can freeze and accumulate on the structure, compared to a submerged discharge into a stilling well. In addition to designing the concrete structures for ice loads, ice loads can also affect the design and operation of outlet works gates or valves. An ice-prevention system may be used to keep the outlet works operational during winter conditions; however, these systems should not be relied on to eliminate ice loads.

In addition to ice loads, frost heave is another load that should be considered. Defensive design measures (such as free-draining fill⁴⁰ next to the walls and other drainage features) are used to mitigate loads associated with frost heave. Sections of an outlet works that may be susceptible to frost heave include portions of inlet structures above the reservoir level, conveyance features such as chutes, and portions of stilling basins above the tailwater level. For more information about mitigating frost heave, refer to *Frost Action in Soil Foundations and Control of Surface Structure Heaving* [51] and *Drainage for Dams and Associated Structures* [52]. For usual loading combinations associated with stability evaluation, see Section 4.8.3, “Stability Design,” in this chapter. For structural design methods, see Section 4.8.4, “Reinforced Concrete Design,” in this chapter.

⁴⁰ Free-draining fill will typically be pervious backfill, which is similar to embankment zones of sands and gravels. Pervious backfill consists of selected materials that are reasonably well graded to 3-inch minus when adjacent to structures and 5- to 6-inch maximum size (except with occasional fragments larger than 5 to 6 inches) when not adjacent to structures. Also, pervious backfill shall not contain more than 5 percent fines (material passing the standard No. 200 sieve).

**Design Standards No. 14: Appurtenant Structures for Dams
(Spillways and Outlet Works) Design Standards**

- **Wind loads.** If no site-specific or regional wind data (using American Society of Civil Engineers [ASCE] 7 [56]) are available, a uniform horizontal load of 30 pounds per square foot per foot ($\text{lb}/\text{ft}^2/\text{ft}$) (corresponding to an 86-mile-per-hour sustained wind) [47] on the exposed area of the outlet works surface feature can be used. For usual loading combinations associated with stability evaluation, see Section 4.8.3, “Stability Design,” in this chapter. In this combination, the wind load may apply if there are high-profile (exposed) outlet works features such as tower intake structures. Wind loads may also apply for unusual loading combinations associated with stability evaluation (see Section 4.8.3, “Stability Design,” in this chapter). For this combination, the wind load may apply during construction and prior to backfilling outlet works features. For structural design methods, see Section 4.8.4, “Reinforced Concrete Design,” in this chapter.

- **Silt loads.** Silt loads could be a factor for outlet works. Situations could occur where silt accumulates adjacent to a submerged intake structure. If no site-specific data are available, an equivalent fluid horizontal pressure of $85 \text{ lb}/\text{ft}^2/\text{ft}$ and a vertical pressure of $120 \text{ lb}/\text{ft}^2/\text{ft}$ can be used [47]. Note that the pressure magnitude varies with depth, and the values include the effects of water within the silt.

- **Earthfill loads.** For lateral loads, both active and at-rest conditions may apply, or, depending on direction of movement, passive conditions may apply. In general, for relatively thin walls, such as those associated with a chute conveyance feature where adjacent fill has not been compacted, there may be sufficient deflection that the active soil wedge will form. However, for more rigid walls or features, such as those associated with a control structure, conduit, and terminal structure, and/or where adjacent fill has been compacted, at-rest lateral loading should be considered. As a general guideline, minimum movement of the wall at the top of fill is related to various design pressures and summarized by the following bullets [55]:
 - **Active pressure.** For loose (uncompacted) fill, minimum movement is $0.002H$; for dense (compacted) fill, minimum movement is $0.0005H$ (where H is depth of fill adjacent to the wall).

 - **Passive pressure.** More movement than cited for active conditions. For loose (uncompacted) fill, minimum movement is $0.006H$; for dense (compacted) fill, minimum movement is $0.002H$.

 - **At-rest pressure.** Less movement than cited for active conditions and more movement than cited for passive conditions.

Chapter 4: General Outlet Works Design Considerations

Note that once walls are deflected, they will remain deflected unless the walls can overcome passive pressure.

Consult with involved geotechnical engineers to develop assumed values if site data are not available. If this is not possible, and there are no site-specific data, equivalent lateral pressures of 40 lb/ft²/ft for pervious backfill and 43 lb/ft²/ft for embankment materials (dry soil), and 85 lb/ft²/ft (saturated soil) can be used (if active pressure conditions apply) [47]. Additionally, unit weights of 120 lb/ft³ for pervious backfill and 130 lb/ft³ for embankment materials (dry soil), and 135 lb/ft³ (saturated soil) can be used as default values. Note that the pressure magnitude varies with depth. Where site-specific data are available, the total lateral soil pressure (based on Mohr-Coulomb considerations) can be estimated. For usual, unusual, and extreme loading combinations associated with stability evaluation, see Section 4.8.3, “Stability Design,” in this chapter. For seismic loading considerations and structural design methods, see Section 4.8.2, “Seismic (Earthquake) Loads,” and Section 4.8.4, “Reinforced Concrete Design,” in this chapter.

- **Construction loads.** A construction load is temporary and should be treated as a surcharge load. These loads may be caused by construction equipment moving adjacent to an outlet works chute wall or adjacent to or over a conduit, or by the storage of construction materials on fill adjacent to a wall. If no site-specific data are available, an approximate equivalent horizontal and vertical uniform surcharge load of 133 lb/ft²/ft and 400 lb/ft²/ft, respectively, can be used. Although this approximate construction load can be used for preliminary or planning-level designs, construction loads for final designs should be based on anticipated equipment moving or placed adjacent to the outlet works. For unusual loading combinations associated with stability evaluation, see Section 4.8.3, “Stability Design,” in this chapter. For structural design methods, see Section 4.8.4, “Reinforced Concrete Design,” in this chapter.
- **Earthquake loads.** See Section 4.8.2, “Seismic (Earthquake) Loads,” in this chapter for selecting the seismic design load(s). Both pseudo-static and dynamic analysis methods may be employed to estimate the response of the structure to the earthquake loads. For extreme loading combinations associated with stability evaluation, see Section 4.8.3, “Stability Design,” in this chapter. For structural design methods, see Section 4.8.4, “Reinforced Concrete Design,” in this chapter.

4.8.2 Seismic (Earthquake) Loads

As a guideline, the initial design earthquake loading conditions for outlet works include:

- **For noncritical⁴¹ features and/or components**, the DBE is assumed as the initial loading condition. The DBE is defined as a seismic event that has a 90-percent probability of nonexceedance in a 50-year timeframe or a return period of about 500 years.
- **For critical⁴² features and/or components**, the 10,000-year earthquake is generally assumed as the initial loading condition. This return period is based on Reclamation’s public protection guidelines of an annualized failure probability of less than $1E-4$ [29]. The final seismic loading generally will not exceed the 50,000-year earthquake and will be dependent on downstream consequences typically evaluated in a risk analysis.

These initial assumed seismic loading conditions may or may not be adequate to reduce or maintain total risks at acceptable levels. Using the process outlined in Table 4.3.2.2-1, “Procedure for Outlet Works Design Using Quantitative Risk Analysis Methodology,” in this chapter, more remote seismic return periods may be needed.

To determine the appropriate seismic loads for an outlet works, identification and evaluation of seismic-induced credible PFMs are undertaken. For more details, see appendix B, which contains a list of typical PFMs for outlet works. If there are seismic-induced credible PFMs, the design load is determined through the process outlined in table 4.3.2.2-1. This process begins with assuming initial design loading conditions.

Analytical tools used to estimate the response of the structure to the earthquake loads involve pseudo-static and dynamic methods. These include:

- **Pseudo-static methods.** These methods are typically used during appraisal and feasibility design. On occasion, these methods may be used during final design when dealing with common, simple structures without complex soil-structure interactions that are subject to small to moderate seismic loading. These pseudo-static methods include:

⁴¹ A noncritical feature is one that could become damaged or fail without leading to damage and/or failure of the dam and without inhibiting outlet works releases to protect the dam [57].

⁴² A critical feature is one in which damage or failure could lead to damage and/or failure of the dam and/or other appurtenant features. Failure may result in uncontrolled releases of the reservoir and/or generate unacceptable downstream hazards. Additionally, failure could also result in an inoperable structure that is unable to make releases to protect the dam against failure [57].

- **Westergaard method.** The Westergaard method estimates hydrodynamic loading. For more details about applying the Westergaard method, see Chapter 6, “Structural Design Considerations for Spillways and Outlet Works,” of this design standard.
- **Mononobe-Okabe method.** The Mononobe-Okabe (M-O) method estimates dynamic lateral soil loading. The M-O theory computes the net static and dynamic force acting on a flexible (yielding) structure. For positive horizontal accelerations (soil accelerates toward the wall), the net dynamic active force (P_{AE}) is greater than the net static active force (P_a), and the net dynamic passive force (P_{PE}) is less than the net static passive force (P_p). Thus, compared with static conditions, the seismic earth pressures increase from the driving side soil mass and decrease from the resisting side soil mass. A limitation of the M-O method in higher seismic regions is that the soil angle of internal friction (ϕ)⁴³ must be greater than the seismic inertial angle (ψ),⁴⁴ which is a function of the horizontal acceleration. The M-O equations yield negative radicals (complex numbers) under such large seismic accelerations. A summary of the fundamental M-O assumptions is presented below:
 - The wall yields sufficiently when subjected to active pressures.
 - The backfill is cohesionless.
 - The soil is assumed to satisfy the Mohr-Coulomb failure criterion.
 - When the minimum active pressure is attained, a soil wedge behind the wall is at the point of incipient failure, and the maximum shear strength is mobilized along the potential slip plane.
 - Failure in the backfill occurs along a slip plane surface that is inclined at some angle with respect to the horizontal backfill passing through the toe of the wall.
 - The soil wedge behaves as a rigid body, and accelerations are constant throughout the mass.

⁴³ Soil angle of internal friction for a given soil is the angle determined from a Mohr’s Circle of the shear stress and normal effective stresses at which shear failure occurs.

⁴⁴ Seismic inertial angle is a function of the horizontal and vertical acceleration coefficients typically expressed as the arc-tangent of the horizontal acceleration coefficient over one minus the vertical acceleration coefficient.

**Design Standards No. 14: Appurtenant Structures for Dams
(Spillways and Outlet Works) Design Standards**

- Equivalent static horizontal and vertical forces are applied at the center of gravity of the wedge and represent the earthquake forces.
- Equivalent liquefaction is not a consideration for the backfill.
- The backfill is completely above or completely below the water table, unless the ground surface is horizontal, in which case the backfill can be partially saturated.
- The ground surface is planar, not irregular or broken.
- Any surcharge is uniform and covers the entire soil surface.
- The soil angle of internal friction must be greater than the seismic inertial angle ($\phi \geq \psi$). The M-O method may not be applicable for large seismic accelerations. For example: a horizontal acceleration of 0.6 g, with a vertical acceleration of 0.0 g and a soil angle of internal friction value of 30 degrees, would result in $\phi < \psi$. The M-O method would not be applicable in this case.

For more details about applying the M-O method, see Chapter E-7, “Seismic Evaluation of Retaining Walls,” in *Best Practices* [9] and Chapter 6, “Structural Design Considerations for Spillways and Outlet Works,” of this design standard.

- **Woods method.** The Woods method estimates dynamic lateral soil loading (only applicable for nonyielding wall conditions). The Woods method is based on linear elastic theory and on idealized representations of the wall-soil structural system. Elastic methods were originally developed and applied for the design of basement walls that would be expected to experience very small displacements under seismic loading and, as such, can be considered as rigid, nonyielding walls. The fundamental assumption for the elastic methods is that the relative soil-structure displacement generates soil stresses in the elastic range of the material. Elastic methods are usually based on elastic wave solutions and are thought to represent upper-bound dynamic earth pressures and, as a result, produce seismic loads greater than those of the M-O method. The Woods method predicts a total dynamic thrust acting at a height equal to approximately 0.58H above the base of the wall. A summary of the fundamental Woods assumptions is presented below:

Chapter 4: General Outlet Works Design Considerations

- The wall is a rigid, nonyielding wall.
- Soil stresses are in the elastic range.
- Computed dynamic thrust loads must be added to static lateral earth loads.
- Computed dynamic thrust loads are a function of the soil Poisson's ratio.
- Computed dynamic thrust loads are a function of the ratio of the effective horizontal length of the backfill to the height of the backfill.
- Not limited for large seismic accelerations.
- The earthquake shaking frequency is much less than the fundamental frequency of the backfill.

For more details about applying the Woods method, see chapter E-7 in *Best Practices* [9] and chapter 6 of this design standard.

- **Self-weight inertia (added mass).** Any pseudo-static analysis will include the inertia forces associated with earthquake-induced acceleration of the spillway structure or feature, such as a wall. For more details, see chapter 6 of this design standard.
- **Dynamic methods.** Linear and nonlinear, two-dimensional and three-dimensional Finite Element Model (FEM) methods are typically employed for some feasibility designs and for some final design level efforts (not all high-level designs will require FEM methods). Also, these methods are used for very large seismic loadings and complex soil-structure interactions. For more details about applying linear and nonlinear, two-dimensional and three-dimensional FEM methods, see chapter E-7 in *Best Practices* [9] and chapter 6 of this design standard.

4.8.3 Stability Design

A number of foundation and structural stability conditions must be evaluated during the analysis and/or design of an outlet works. These conditions are grouped by loading combinations and are discussed in the following sections.

**Design Standards No. 14: Appurtenant Structures for Dams
(Spillways and Outlet Works) Design Standards**

4.8.3.1 Loading Combinations

Loading combinations for outlet works stability design typically are grouped into three categories, including:

- **Usual (normal or service) loading combination.** Loading conditions include the maximum normal RWS, with appropriate dead loads, uplift, silt, ice, and tailwater. Foundation and structural stability should be evaluated for this loading combination, which is further discussed in Section 4.8.3.2, “Stability Conditions,” in this chapter.
- **Unusual loading combination.** Loading conditions include the flood-induced maximum design RWS, with appropriate dead loads, uplift, silt, and tailwater. (Note: In some cases, these loading conditions have been evaluated as an extreme loading combination primarily when the maximum design flood is associated with an extremely remote event, such as the PMF). A variation of the loading combination is to assume that the drainage system is inoperable and evaluate this with full uplift. Foundation and structural stability should be evaluated for this loading combination, which is further discussed in Section 4.8.3.2, “Stability Conditions,” in this chapter.
- **Extreme loading combination.** Loading conditions include maximum normal RWS, with appropriate dead loads, uplift, silt, ice,⁴⁵ and tailwater, plus earthquake loadings. Foundation and structural stability should be evaluated for this loading combination, which is further discussed in Section 4.8.3.2, “Stability Conditions,” below.

4.8.3.2 Stability Conditions

As previously noted, stability conditions are evaluated, and the methods used are summarized below:

- **Overturning displacement** occurs when a structural feature (such as a wall) rotates about an axis point (such as the end base point of the wall), or the sum of the overturning (destabilizing) moments about the end base point of the wall exceeds the sum of the resisting (stabilizing) moments about the end base point of a wall [55]. Outlet works features typically evaluated for overturning displacement include: tower intake structures and/or counterforted walls; control structures including wet wells, along with any control structure with cantilever, gravity, and/or counterforted walls; conveyance features, specifically chutes with cantilever, gravity, and/or counterforted walls; and terminal structures with cantilever,

⁴⁵ Ice loads would be included if present for a significant part of the winter. Ice loads would not be included if limited to days to several weeks.

Chapter 4: General Outlet Works Design Considerations

gravity, and/or counterforted walls. Of note, if the resultant of all forces acting on the feature falls within the middle third of the base of the feature, adequate safety against overturning exists. The governing equation is:

$$SF_{OVERTURNING} = \frac{\sum M_{RESISTING}}{\sum M_{OVERTURNING}}$$

- Where:
- $SF_{OVERTURNING}$ is the safety factor (see Table 4.8.3.2-1, “Minimum Safety Factors,” which appears later in this document).
 - $\sum M_{RESISTING}$ is the sum of (total) resisting moments about designated tipping point (such as the toe of a retaining wall) and can include the effects of anchor bars and/or rock bolts (foot-pounds [ft-lb]).
 - $\sum M_{OVERTURNING}$ is the sum of (total) overturning moments about designated tipping point (such as the toe of a retaining wall) (ft-lb).

- **Sliding displacement** occurs when a structural feature (such as a chute conveyance feature) slides along the contact with the foundation, and the adjacent foundation slides along joints and/or zones of weakness within the foundation. Sliding occurs when the sum of the driving forces exceeds the sum of the resisting forces (shear strength of the foundation contact and/or foundation) [55]. Spillway features typically evaluated for sliding displacement include: inlet structures; control structures; conveyance features, specifically chutes; and terminal structures. The governing equation is:

$$SF_{SLIDING} = \frac{CA + (\sum N + \sum U) \tan \phi}{\sum V}$$

- Where:
- $SF_{SLIDING}$ is the safety factor (see Table 3.8.3-1, “Minimum Safety Factors”).
 - C is the cohesion at the interface between the structure and foundation (lb/ft²).
 - A is the contact area of the interface between the structure and foundation (ft²).
 - $\sum N$ is the sum of the normal forces acting on the interface between the structure and foundation (lb).
 - $\sum U$ is the sum of the uplift forces acting on the interface between the structure and foundation (designated as negative values) (lb).

**Design Standards No. 14: Appurtenant Structures for Dams
(Spillways and Outlet Works) Design Standards**

$\tan\phi$ is the coefficient of internal friction associated with the interface between the structure and foundation.

$\sum V$ is the sum of the shear forces acting on the interface between the structure and foundation (lb).

- **Bearing capacity displacement** occurs when the bearing pressure of the outlet works feature (such as a tower intake structure) exceeds the ultimate bearing capacity (shear strength) associated with its foundation (rock or soil). If site-specific data are not available, consultation with involved geotechnical engineers and/or geologists may be warranted. Also, an initial assumption can be made that the allowable bearing pressure is one-half (for soil foundation) to one-quarter (for rock foundation) of the ultimate bearing capacity [55]. Spillway features typically evaluated for bearing capacity displacement include: inlet structures; control structures; conveyance features, specifically chutes; and terminal structures. The governing equation is:

$$SF_{BEARING} = \frac{P_{ULTIMATE}}{P_{CALCULATED}}$$

Where: $SF_{BEARING}$ is the computed safety factor that must be greater than the required minimum safety factor (see Table 4.8.3.2-1, “Minimum Safety Factors”).

$P_{ALLOWABLE}$ is the maximum allowable pressure permitted for a given foundation (this will be a percentage of the ultimate bearing capacity of the foundation $P_{ULTIMATE}$) (lb/ft²).

$P_{CALCULATED}$ is the calculated pressure acting on a given foundation (lb/ft²).

$P_{ULTIMATE}$ is the maximum pressure that a foundation can sustain without exceeding the shear strength of the foundation (lb/ft²).

- **Floataion displacement** occurs when the vertical load (weight) of the outlet works feature (such as a stilling basin terminal structure which has been isolated from the tailwater by stoplogs and unwatered, or when a stilling basin sweepout occurs; i.e., the hydraulic jump is pushed downstream out of the stilling basin) is exceeded by buoyant forces (such as the uplift due to tailwater around the outlet works feature). Outlet works features typically evaluated for floataion displacement include: isolated and unwatered submerged intake structures; isolated and unwatered conveyance features, specifically conduits; isolated and unwatered terminal structures; and during operation with the minimum depth of flow (d_1) entering the stilling basin (upstream of the hydraulic jump), and the

Chapter 4: General Outlet Works Design Considerations

conjugate depth of flow (d_2) exiting the stilling basin (downstream of the hydraulic jump). Of note, safety factors for floatation are typically calculated assuming that drains are not functioning and anchor bars are not considered. The governing equation is:

$$SF_{FLOATATION} = \frac{\sum L}{\sum U}$$

Where: $SF_{FLOATATION}$ is the computed safety factor that must be greater than the required minimum safety factor (see Table 4.8.3.2-1, “Minimum Safety Factors”).

$\sum L$ is the sum of (total) vertical forces acting on the interface between the structure and foundation (lb).

$\sum U$ is the sum of the uplift forces acting on the interface between the structure and foundation (lb).

Minimum safety factors have been established and are associated with loading combinations (see Section 4.8.3.1, “Loading Combinations” in this chapter). Note that higher safety factors for both new and existing outlet works may be required to meet Reclamation’s quantitative risk analysis guidelines. The safety factors are summarized in table 4.8.3.2-1.

Table 4.8.3.2-1. Minimum Safety Factors

Stability Conditions	Load Combinations	Minimum Safety Factors
Overturning*	Usual (normal)	1.5**
	Unusual	1.15**
	Extreme	1.15**
Sliding	Usual (normal)	1.5**
	Unusual	1.15**
	Extreme	1.15**
Bearing capacity	Usual (normal) - soil	2.0**
	Usual (normal) - rock	4.0**
	Unusual - soil	1.5**
	Unusual - rock	3.0**
	Extreme - soil	1.5**
	Extreme - rock	3.0**
Floatation	Usual (normal)	1.2***
	Unusual	1.1***
	Extreme	1.1***

* Low overturning safety factors are likely to be an indicator that other types of instability can occur, such as bearing capacity or sliding due to shearing at the base of the structure. This is due to rotating a structure about a point which will result in high stress concentrations in the structure and/or foundation.

** Reference: *Design Criteria for Concrete Retaining Walls* [55]

*** Reference: Chapter 2, “Structural Design Data,” of Design Standards No. 9 [58].

Design Standards No. 14: Appurtenant Structures for Dams (Spillways and Outlet Works) Design Standards

Again, it is stressed that these are minimum (default) safety factors that may need to be increased to achieve acceptable risk levels associated with Table 4.3.2.2-1, “Procedures for Outlet Works Design Using Quantitative Risk Analysis Methodology.”

4.8.4 Reinforced Concrete Design

Reclamation has been designing concrete structures for over 100 years, and many changes and advancements have occurred. One of the more significant design changes has been the shift from the Alternate Design (Working Stress Design) Method⁴⁶ to the Strength Design Method.⁴⁷ Current Reclamation reinforced concrete design methodology employs the ACI building codes as a minimum. For most hydraulic structures, such as outlet works, ACI 350-06, *ACI Code Requirements for Environmental Engineering* [53], is used to establish minimum reinforced concrete design levels. For significant- and high-hazard storage and multipurpose dams and their appurtenant structures (such as outlet works), a risk-based evaluation, analysis, and/or design will typically be needed, resulting in designs equal to or exceeding the applicable ACI building codes. Applying risk methodology to evaluation, analysis, and/or design associated with modifying an existing outlet works or constructing a new outlet works is outlined in Table 4.3.2.2-1, “Procedure for Outlet Works Design Using Quantitative Risk Analysis Methodology,” in this chapter, and it is further discussed in various chapters of *Best Practices* [9].

A brief overview of reinforced concrete design is discussed in the following paragraphs.

4.8.4.1 Strength Design

This design approach is based on the fundamental concept that structures and structural members shall be designed to have design strengths at all sections at least equal to the required strengths calculated for the factored loads and forces in such combinations as stipulated in ASCE 7, *Minimum Design Loads for Buildings and Other Structures* [56] and ACI 318, *Building Code Requirement for Structural Concrete and Commentary* [54]. This basic requirement for strength design can be expressed as:

⁴⁶ For the Alternate Design Method, a structural element is designed so that stresses from service loads do not exceed allowable values. Stresses computed by this method will be within the elastic range, and straight-line variation between stress and strain is used. As of 2002, this method has been eliminated from the ACI building codes.

⁴⁷ For the Strength Design Method, the service loads are increased by load factors to obtain the ultimate design load. The structural element is then designed to provide the desired ultimate design strength. The method takes into account the nonlinear stress-strain behavior of concrete.

$$\text{Design Strength} \geq \text{Required Strength}$$

The design strength provided by a member in terms of flexure, axial load, shear, and torsion is taken as the nominal strength determined in accordance with the requirements and assumptions of ACI 318, multiplied by the appropriate strength reduction factors (ϕ) presented in the same code [54]. This is expressed as:

$$\text{Design Strength} = \phi (\text{Nominal Strength})$$

The required strength (U) is expressed in terms of combinations of factored loads, or related internal moments and forces. Factored loads are applicable loads specified in general building codes, such as ASCE 7 [56], multiplied by appropriate load factors (LF). This is expressed as:

$$\text{Required Strength } (U) = LF (\text{Load})$$

In strength design, the margin of safety is provided by the combined effects of multiplying the computed service loads by the appropriate load factor and multiplying the nominal (expected) strength by a strength reduction factor.

4.8.4.2 Loads

The loads that are generally considered for designing outlet works structures may include, but are not limited to:

- Permanent loads:
 - D = dead loads from structural and mechanical components
 - F = vertical load from weight of soil or water
 - H = static lateral earth pressure (including surcharge) and lateral water pressure loads

- Transient loads:
 - E = Earthquake loads
 - S = Snow/ice loads
 - L = Live loads
 - T = Temperature loads
 - W = Wind loads

For more information about loads, see Section 4.8.1, “Loading Conditions,” in this chapter.

4.8.4.3 Load Combinations

The load combinations associated with load factors for strength design are provided in chapter 2 of ASCE 7 [56]. Load factors are assigned by structural code based on the degree of accuracy to which the load effect can be calculated

Design Standards No. 14: Appurtenant Structures for Dams (Spillways and Outlet Works) Design Standards

and the variation that might be expected in the load during the lifetime of the structure. Load factors also account for the variability in the structural analysis used to compute moments and shears.

4.8.4.4 Load Factors

Typical load combinations used for the design of outlet works are presented below; however, the designer must refer to chapter 2 of ASCE 7 [56] to determine all appropriate load combinations and load factors:

$$U = 1.4 (D+F)$$

$$U = 1.2 (D+F+T) + 1.6 (L+H) + 0.5S$$

$$U = 1.2D + 1.6S + (L \text{ or } 0.8W)$$

$$U = 1.2D + 1.6W + L + 0.5S$$

$$U = 1.2D + 1.0E + L + 0.2S$$

$$U = 0.9D + 1.6W + 1.6H$$

$$U = 0.9D + 1.0E + 1.6H$$

Seismic load factors need special consideration for Reclamation designs. Specifically, earthquake loads are determined based on risk-based studies and, as such, seismic load factors should be determined relative to the level of seismic design established on a project-by-project basis.

4.8.4.5 Strength Reduction Factors (ϕ)

These factors for reinforced concrete strength design are provided in ACI 318 [54]. The purpose of strength reduction factors is to allow for the probability of under-strength members, due to variations in material strengths and dimensions, to allow for inaccuracies in design equations, to reflect the degree of ductility, to reflect the required reliability of the member under load effects being considered, and to reflect the importance of the member in the structure. Strength reduction factors provided in ACI 318 [54] include:

$$\phi_{tens} = 0.9 \text{ for tension controlled sections}$$

$$\phi_{comp} = 0.65 \text{ for compression controlled sections}$$

$$\phi_{spiral} = 0.75 \text{ for compression controlled sections with adequate spiral reinforcement}$$

$\phi_{shear} = 0.75$ for shear

$\phi_{torsion} = 0.75$ for torsion

4.8.4.6 Serviceability Considerations for Hydraulic Structures

Hydraulic structures, such as outlet works, have unique serviceability requirements that need to be considered as part of their design. Specifically, outlet works structures are expected to be durable structures with a design life in excess of 50 years. Their ability to perform as designed under unusual flood conditions is paramount to the overall safety of the dam. In addition, they are often subjected to harsh environments, including extreme temperature variations and severe wet and dry cycles.

ACI 350 [53] uses an environmental durability factor (S_d) to reduce the effective stress and limit the extent and width of concrete cracks to provide additional durability throughout the design life of the structure. The value of S_d varies with individual load factors and with the applicable strength reduction factors. The required strength U listed in section 4.8.4.4 is multiplied by S_d .

USACE Engineering Manual EM-1110-2-2104 [59] uses minimum load factors that have been increased to provide the same effect as the environmental durability factor in ACI 350. The load factors for serviceability are applied for usual and unusual loads, and the load factors for strength are applied for extreme loads. EM-1110-2-2104 uses USACE specific return periods for categorizing loads as usual, unusual, or extreme. For Reclamation designs, return periods for these load categories will be developed on a case-by-case basis if the factors in EM-1110-2-2104 are used.

An additional serviceability consideration is protecting the concrete flow surfaces from erosion due to abrasion from high velocity flows or high levels of sediment being passed. The concrete may be protected by increasing the thickness of the concrete (increasing clear cover) to provide a sacrificial layer of concrete. For the regulating valves (fixed-cone valves) at Jordanelle Dam, a steel liner was used in the energy dissipation structure to protect the concrete from high velocity flow induced erosion.

4.8.4.7 New Concrete and Reinforcement Properties

In the absence of laboratory testing data and site-specific design data, the following concrete material properties can be used for reinforced concrete design of a new outlet works or for modifications to an existing outlet works:

- Compressive strength at 28 days (f_c') = 4,500 lb/in² (f_c' is based on ACI 318 [54] or 350 [53] exposure category F1, F2, and F3, where concrete is exposed to moisture and cycles of freezing and thawing).

Design Standards No. 14: Appurtenant Structures for Dams (Spillways and Outlet Works) Design Standards

- Tensile strength (f_t) = 0.04 to 0.06 f_c'
- Shear strength:
 - Cohesion (c) = 0.1 f_c'
 - Coefficient of internal friction ($\tan\phi$) = 1.0
- Sustained (static) modulus of elasticity (E_s) = 4.1E6 lb/in²
- Coefficient of thermal expansion (α) = 5.0E-6 °F
- Poisson's ratio (μ) = 0.20
- Unit weight (γ_c) = 150 lb/ft³

Also, all reinforcing bars will have a yield strength (f_y) of 60,000 lb/in². Furthermore, with few exceptions, using corrosion protection,⁴⁸ such as epoxy-coated reinforcing bars, is not standard practice.

4.8.4.8 Existing Concrete and Reinforcement Properties

A consideration that should not be overlooked when dealing with modifying existing structures is determining the material properties and design methods used for an existing outlet works. Ideally, there are existing technical references that document the original material properties and design methods, or field testing will be done to determine the existing material properties. However, in some cases where technical information is not available, engineering judgment must be employed, which can be supported by a good understanding of the evolution of concrete and reinforcement during the last century. An approach used by Reclamation is based on the existing outlet works' time of construction, using information found in Chapter 6, "Structural Considerations for Spillways and Outlet Works," of this design standard, and other references [60] to identify likely concrete material properties and reinforcing bar yield strength and sizes for that period. As an example, reinforcement embedment and splice lengths in older concrete structures may not be adequate to develop the full strength of the reinforcing bars, thus limiting the effectiveness of the reinforcement in critical (high stress) areas of the structure. Note that reasonable ranges of concrete material properties and reinforcing bar data should be used in a parametric (sensitivity) evaluation, to reflect potential concrete strength gain (or loss) over

⁴⁸ Adequate corrosion protection can typically be achieved by encasing the reinforcing bars in concrete. Additional corrosion protection, such as cathodic protection or epoxy-coated reinforcing bars, seldom has been considered given any additional benefits versus cost.

time, and potential variation in reinforcing steel properties. The results of this parametric evaluation would be incorporated into the overall modification design of the outlet works.

4.8.5 Reinforcement

The sizing and layout of reinforcement is an important design activity, and the level of effort will be influenced by the approach used to portray reinforcement. One of two reinforced structural specifications drawing formats will apply [61]:

- **Typical sections and window drawings.** Applicable to simple structures (such as a grade control sill or a small chute or retaining wall) and may be included as part of the outline drawings. This type of reinforcement detailing must be sufficient to bid, inspect, and construct the structure without further information. Typical placement patterns of reinforcement are shown in “windows” with reinforcing bar size and spacing indicated (not all reinforcing bars are shown).
- **Detailed concrete reinforcement design drawings.** Applicable to most features (such as control structures, chutes, conduits, tunnel lining, and terminal structures) that are not considered simple structures. These are typically separate drawings from the outline drawings. These drawings show reinforcing bars in at least two views (plan, profile, section, and/or details) and define true length, shape, size, number, and location, along with sufficient detail for the contractor to determine the placement patterns of reinforcement. This also allows construction management staff to determine if the reinforcement placement patterns meet the design intent.

Guidelines concerning reinforcement layout can be found in *ACI Detailing Manual 2004* (SP-66) [62]. Also, see TM TSC-8100-Standards-2016-1 (Standard Drawings 40-D-60003 and 40-D-60004, Revision 0 – “Background and Development”) [63]. In addition to these references, other general design considerations are further discussed in the Working Document – GUI-8130-1, *Detailed Reinforcement Drawing Guidelines* [64], found in Chapter 6, “Structural Considerations for Spillways and Outlet Works,” of this design standard.

4.8.6 Joints, Waterstops, and Tolerances

Design considerations involve identifying and locating joints and waterstops, along with specifying surface tolerances for reinforced concrete outlet works, which are summarized in the following sections.

**Design Standards No. 14: Appurtenant Structures for Dams
(Spillways and Outlet Works) Design Standards**

4.8.6.1 Joints

Identifying and locating joints for modified and new reinforced concrete outlet works are important design considerations. Particularly for flow surfaces, proper detailing can mitigate the development of adverse hydraulic conditions such as stagnation pressure and/or cavitation. The majority of joints associated with an outlet works include construction joints (CJ), contraction joints (CrJ), and control joints (CtJ). Additionally, on a limited basis, expansion joints (EJ) are used on some outlet works features such as access bridges and limited to non-water bearing walls. With some exceptions, these joints are oriented perpendicular and parallel to the outlet works centerline (floor, conduit/tunnel joints) and vertical (wall, conduit/tunnel joints). Further details concerning these joints are provided below.

4.8.6.1.1 Construction Joints

The CJs are chemically bonded surfaces or planes produced by placing fresh concrete against surfaces of clean hardened concrete. Reinforcement is continuous across CJs, and waterstops and keys are seldom used (see figure 4.8.6.1.1-1). The expectation is that CJs will be as strong as the concrete matrix (i.e., not create a plane of weakness). To ensure bonding, the joint surface of the existing concrete to be covered with fresh concrete should be clean, roughened, and SSD. For definition of SSD, see Section 4.7.2.1.4, “Cleanup,” in this chapter. This would include removing all laitance, loose or defective concrete, coatings, sand, curing compound, and other foreign materials. Sandblast, steel shotblast, high-pressure water jet, or other methods approved by Reclamation may be used to create acceptable surfaces. The location and spacing of the CJs are governed by the anticipated concrete placement capacity, concrete forming requirements, and requirements for second-stage concrete construction (such as installation of metal work in a blockout that is later filled with concrete). The CJs are also intended to reduce initial shrinkage stresses and cracks. The CJ locations are usually planned (located) as part of the design and shown on the drawings. Optional construction joints (OCJs) may also be added by the designer and shown on the drawings. The OCJs are intended to facilitate construction but are not required. Use of the OCJs shown on the drawings is up to the contractor. Additional CJs requested by the contractor must be approved by the designer of record. Some CJs may be required because of inadvertent and/or unanticipated delays (due to weather, equipment breakdown, etc.) in concrete placement. The CJ orientation is typically horizontal (separating one concrete placement from the next concrete placement, such as placing an outlet works conduit arch section on the previously placed conduit base section). An exception is using CJs normal to the flow direction in tunnels. Vertical and/or diagonal orientation of a CJ can be satisfactorily achieved with appropriate levels of care and oversight during construction. Examples of horizontal and vertical CJs are shown in figure 4.8.6.1.1-1.

Chapter 4: General Outlet Works Design Considerations



Construction of new river outlet works - conduit sections and stilling basin wall of river outlet works, which employs horizontal CJs between concrete placements



CJs

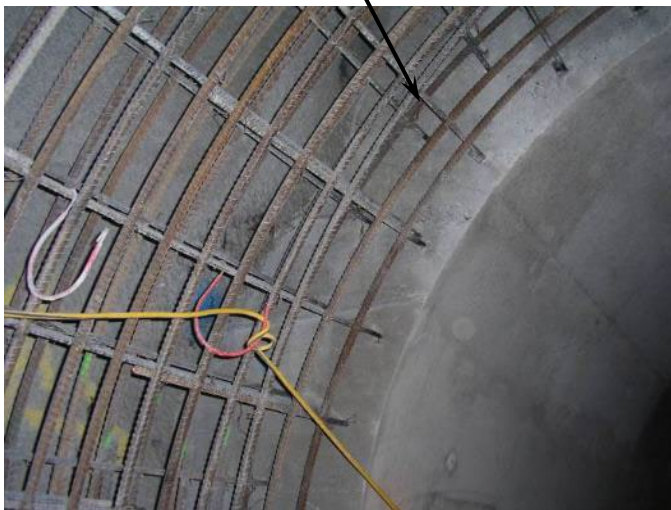

Construction of new river outlet works – tunnel section which employs vertical CJs

Figure 4.8.6.1.1-1. CJ orientation (horizontal and vertical).

**Design Standards No. 14: Appurtenant Structures for Dams
(Spillways and Outlet Works) Design Standards**

4.8.6.1.2 Contraction Joints

The CrJs are unbonded surfaces separating adjacent concrete placements. Sealing and/or curing compounds or other bond breakers are placed against the existing concrete on the initially cast portion of concrete to prevent bonding with the concrete placed against it. Separation of adjacent concrete placements and/or structures is used to relieve tensile stresses and cracking induced by shrinkage. For longitudinal floor joints, CrJs are vertical and extend from the foundation to the top of the concrete placement. Transverse floor CrJs are normal (90 degrees) to the centerline of the outlet works and normal to the slope of the flow surface.

Transverse wall CrJs are normal (90 degrees) to the centerline of the outlet works and vertical. For details of flow surface CrJs, see figures 4.8.6.1.2-1, 4.8.6.1.2-2, and 4.8.6.1.2-3. Reinforcement is not continuous across CrJs to prevent any moment transfer (floor CrJs are an exception, where plain reinforcing dowels extend across the CrJs). With few exceptions, waterstops (see Section 4.8.6.2, “Waterstops,” in this chapter for more information, and see standard drawing 40-D-6463) are used for flow surface CrJs, and formed concrete keys across the CrJs may be employed (see standard drawing 40-D-5249).⁴⁹ The location and spacing of CrJs should be governed by the physical features of the outlet works, temperature study results, concrete placement methods, and the potential concrete placing capacity. Also, foundation conditions (such as a transition from rock foundation to soil foundation) may be a factor in location of floor CrJs. Typical CrJ spacing ranges from 15 to 40 feet. It is highlighted that large spacing (typically greater than 20 feet) could be more susceptible to shrinkage cracking. When considering large spacing of joints, consideration should be given to undertaking concrete mix designs and temperature studies to evaluate cracking potential and joint spacing.

4.8.6.1.3 Control Joints

The CtJs are unbonded surfaces separating adjacent concrete placements. Sealing and/or curing compound or other bond breakers are placed against the concrete on the initially cast portion of concrete to prevent bond with the concrete placed against it. Separation of adjacent concrete placements and/or structures is used to relieve tensile stresses and cracking induced by shrinkage. For longitudinal floor joints, CtJs are vertical and extend from the foundation to the top of the concrete placement. Transverse floor, conduit, and tunnel CtJs are normal (90 degrees) to the centerline of the outlet works and normal to the slope of the flow surface. For details of flow surface CtJs, see figures 4.8.6.1.3-1, 4.8.6.1.3-2, and 4.8.6.1.3-3.

⁴⁹ Standard drawings are not included with this design standard due to the frequency of change (typically, standard drawings are reviewed and updated whenever the ACI building code is updated, which is more frequently than design standards are updated). Standard drawings may be accessed by Reclamation staff through the INTRANET, while non-Reclamation staff can request standard drawings.

Chapter 4: General Outlet Works Design Considerations

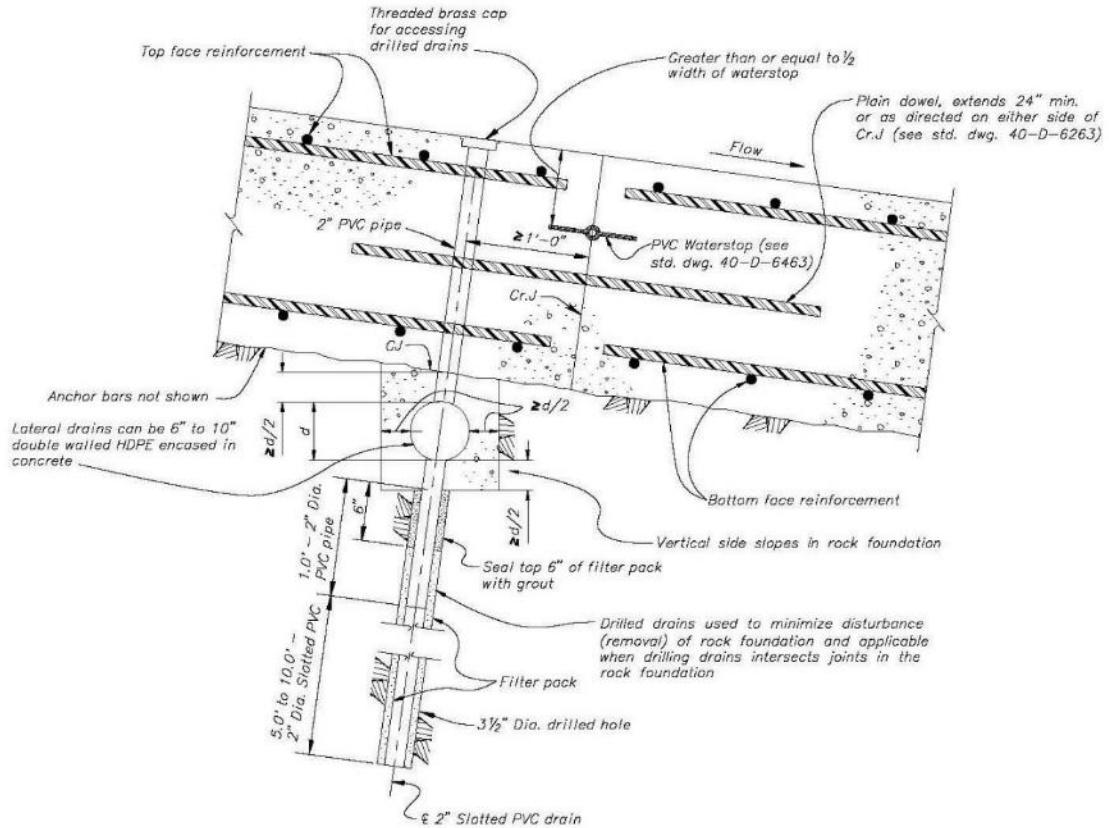

CASE 1A: ROCK FOUNDATION WITHOUT FOUNDATION KEY – FLAT TO GRADUAL SLOPE – APPLICABLE FEATURE IS TERMINAL STRUCTURE (STILLING BASIN)

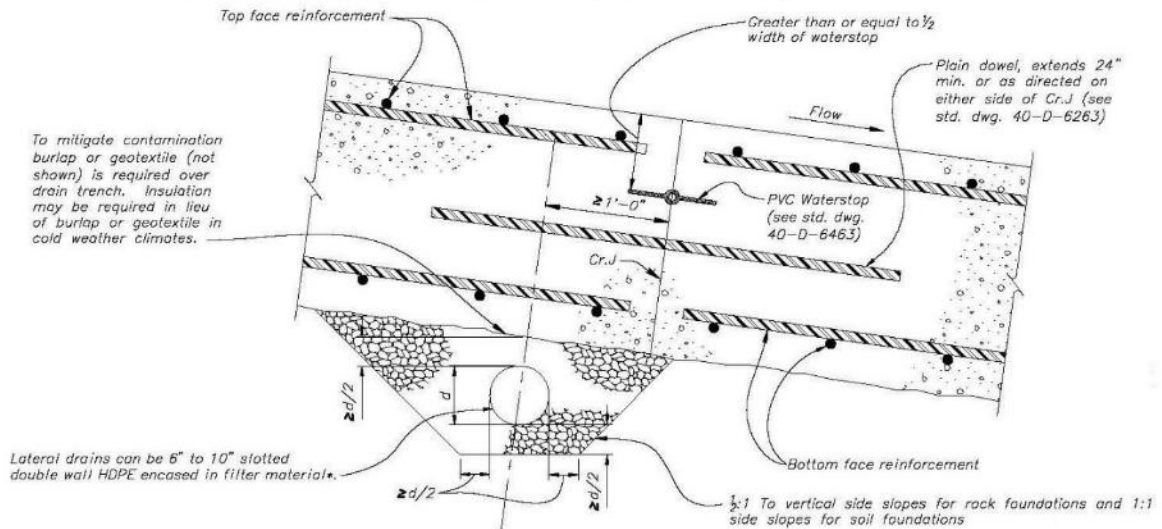

CASE 1B: ROCK OR SOIL FOUNDATION WITHOUT FOUNDATION KEY – FLAT TO GRADUAL SLOPES – APPLICABLE FEATURE IS TERMINAL STRUCTURE (STILLING BASIN)

Figure 4.8.6.1.2-1. Transverse CrJs without foundation keys for flow surface slabs.

**Design Standards No. 14: Appurtenant Structures for Dams
(Spillways and Outlet Works) Design Standards**

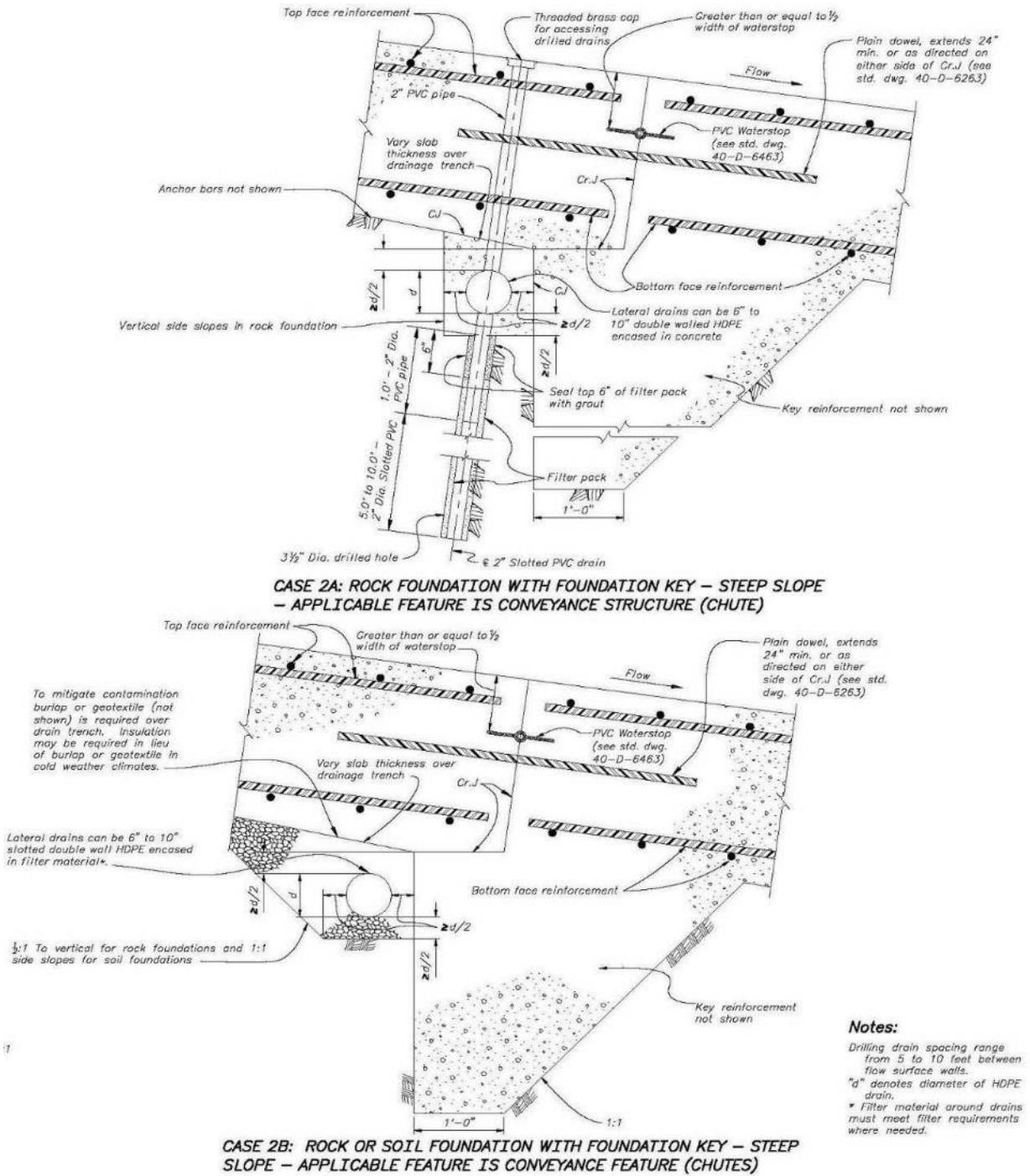
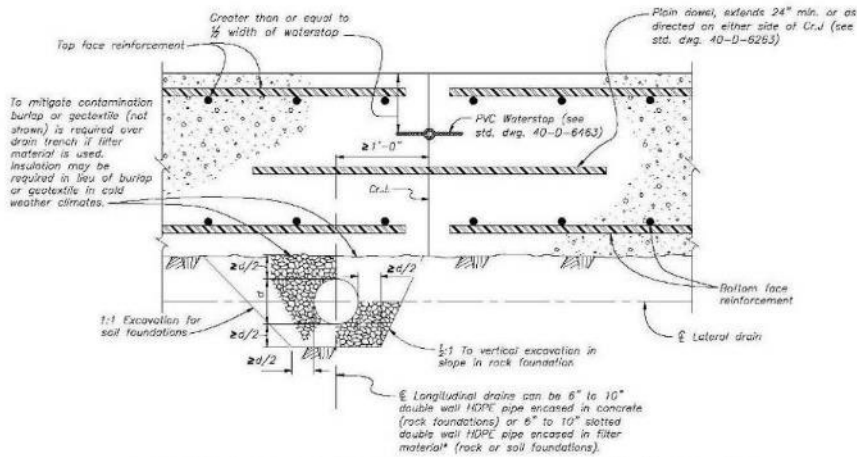

Figure 4.8.6.1.2-2. Transverse CrJs with foundation keys for flow surface slabs.

Chapter 4: General Outlet Works Design Considerations



FLOW SURFACE SLAB – LONGITUDINAL CONTRACTION JOINT (Cr.J) ON ROCK OR SOIL FOUNDATION WITHOUT FOUNDATION KEY – APPLICABLE FEATURES ARE CONVEYANCE FEATURES (CHUTES) AND TERMINAL STRUCTURES (STILLING BASIN)

Notes:

Drilling drain spacing range from 5 to 10 feet between flow surface walls.

"d" denotes diameter of HDPE drain.

* Filter material around drains must meet filter requirements where needed.

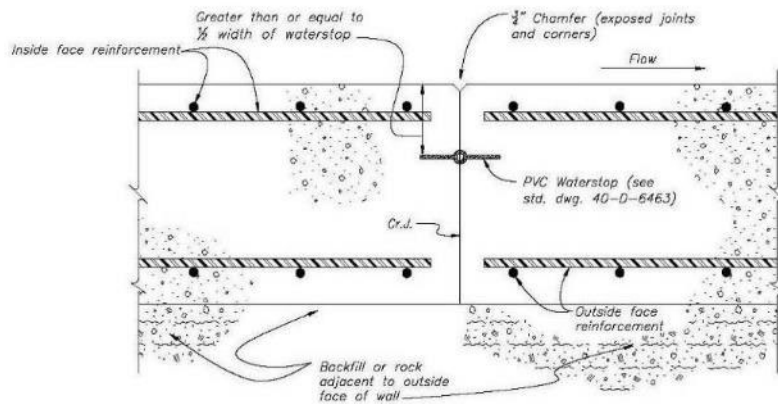

FLOW SURFACE WALL – LATERAL (TRANSVERSE) CONTRACTION JOINT (Cr.J) THRU WALL – APPLICABLE FEATURES ARE CONVEYANCE FEATURES (INLET STRUCTURE AND CHUTE), CONTROL STRUCTURE, AND TERMINAL STRUCTURE (STILLING BASIN)

Figure 4.8.6.1.2-3. Longitudinal CrJs for flow surface slabs and transverse CrJs for flow surface walls.

**Design Standards No. 14: Appurtenant Structures for Dams
(Spillways and Outlet Works) Design Standards**

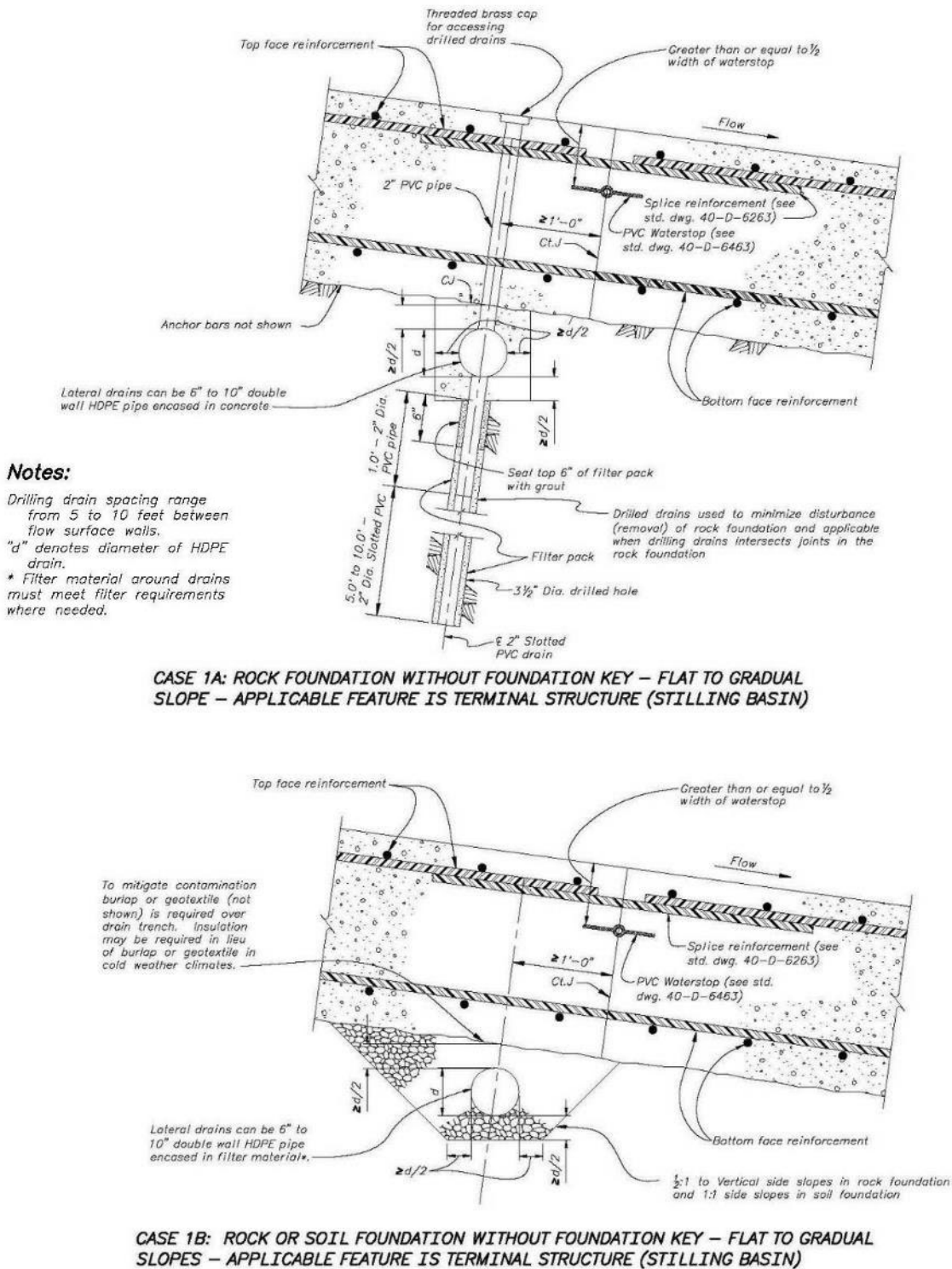

Figure 4.8.6.1.3-1. Transverse CtJs without foundation keys for flow surface slabs.

Chapter 4: General Outlet Works Design Considerations

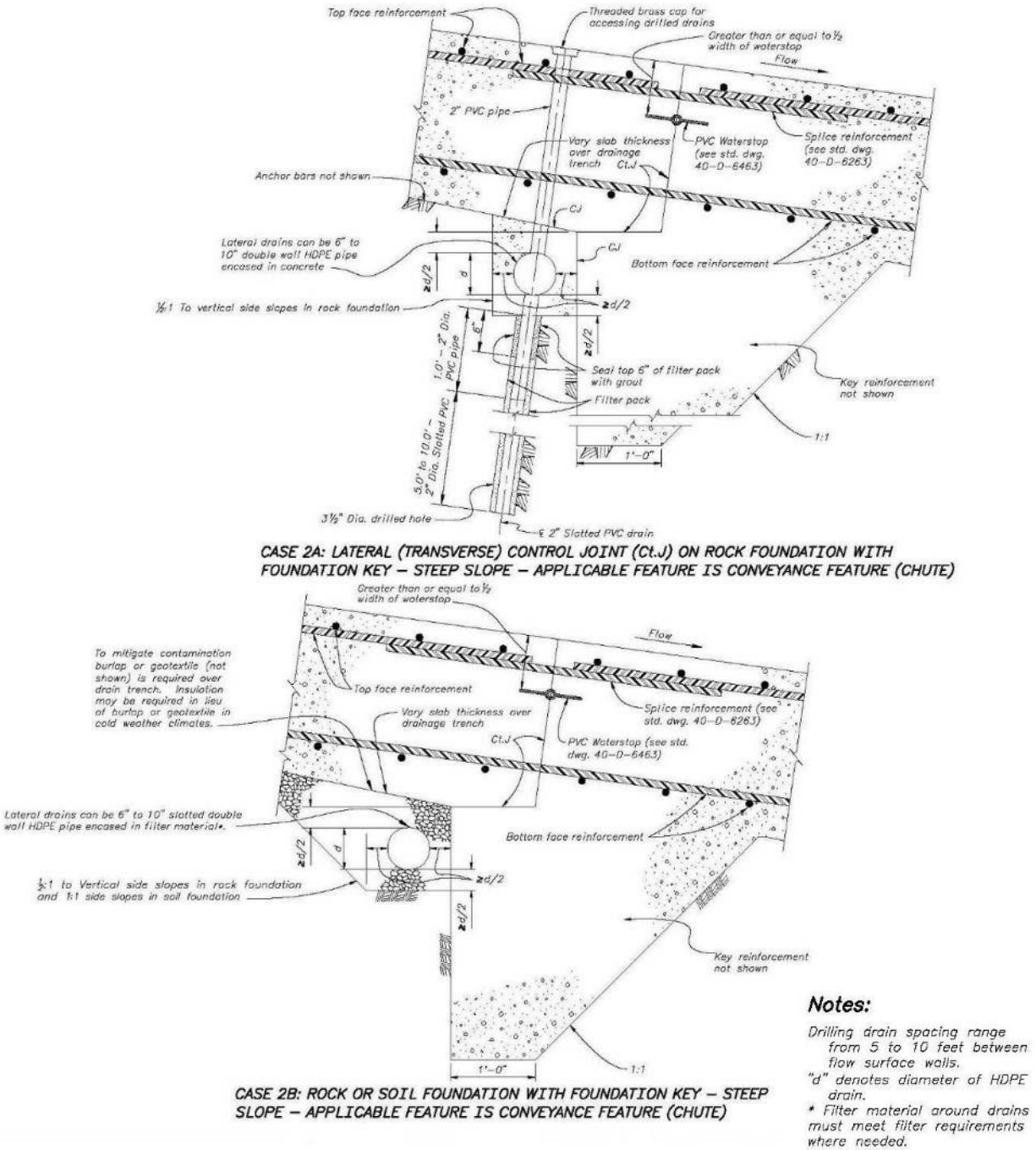
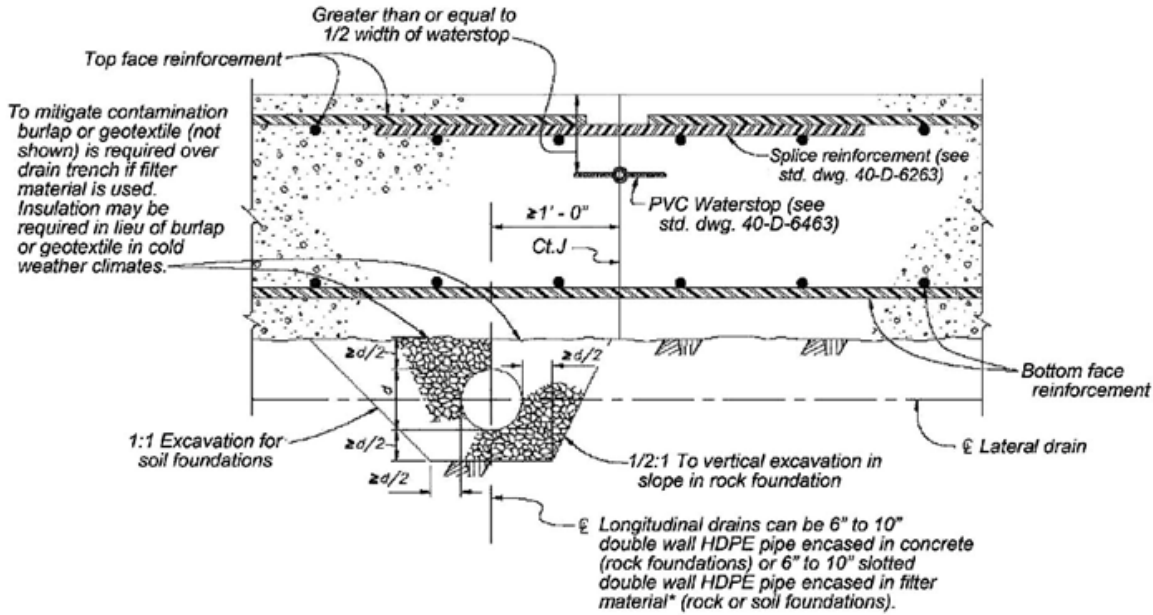

Figure 4.8.6.1.3-2. Transverse CtJs with foundation keys for flow surface slabs.

**Design Standards No. 14: Appurtenant Structures for Dams
(Spillways and Outlet Works) Design Standards**



FLOW SURFACE SLAB – LONGITUDINAL CONTROL JOINT (Ct.J) ON ROCK OR SOIL FOUNDATION WITHOUT FOUNDATION KEY – APPLICABLE FEATURES ARE CONVEYANCE FEATURES (CHUTE) AND TERMINAL STRUCTURES (STILLING BASIN)

Notes:

Drilling drain spacing range from 5 to 10 feet between flow surface walls.
 "d" denotes diameter of HDPE drain
 * Filter material around drains must meet filter requirements where needed.

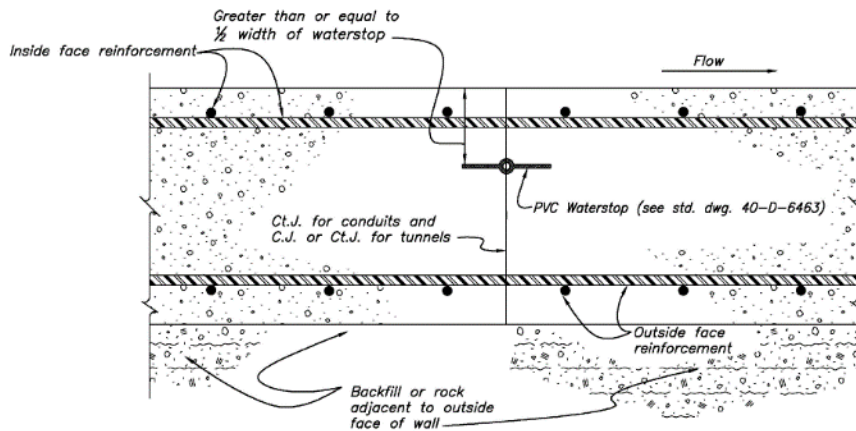

FLOW SURFACE CONDUIT OR TUNNEL – LATERAL (TRANSVERSE) CONTROL JOINT (Ct.J) THRU CONDUIT AND CONSTRUCTION JOINT (C.J.) OR Ct.J. THRU TUNNEL – APPLICABLE FEATURE IS CONVEYANCE FEATURE

Figure 4.8.6.1.3-3. Longitudinal CtJs for flow surface slabs and transverse CtJs and CJs for flow surface conduits and tunnels.

Reinforcement is continuous across CtJs to allow moment transfer and can facilitate the bridging of the concrete feature over localized differential movement (settlement) of the foundation. With few exceptions, waterstops (see Section 4.8.6.2, “Waterstops,” in this chapter for more information, and see standard drawing 40-D-6463) are used for flow surface joints, and formed concrete keys across the CtJs may be employed (see standard drawing 40-D-5249).

The location and spacing of CtJs should be governed by the physical features of the outlet works, temperature study results, concrete placement methods, and potential concrete placing capacity. Also, foundation conditions (such as a transition from rock foundation to soil foundation) may be a factor in location of floor CtJs. Typical CtJ spacing ranges from 15 to 40 feet. It should be noted that large spacing (typically greater than 20 feet) could be more susceptible to shrinkage cracking. When evaluating large spacing of joints, consideration should be given to undertaking concrete mix designs and temperature studies to evaluate cracking potential and joint spacing.

For closely spaced reinforcement, a different splice detail for the top face has been used to reduce the chance of delamination at the joint (see Section 4.8.6.1.4, “Surface Delaminations Near CrJs and CtJs,” in this chapter). Instead of locating the splice in the same plane as the reinforcement pattern (and potentially introducing a plane of weakness), the reinforcing bars are stopped on each side of the joint, and a single splice bar is placed below the reinforcement that splices to each bar on either side of the CtJ. This detail can be seen in figures 4.8.6.1.3-1, 4.8.6.1.3-2, and 4.8.6.1.3-3.

4.8.6.1.4 Surface Delamination near CrJs and CtJs

Delamination and/or spalling have been observed near exposed slab CrJs and CtJs and are associated with outlet works surface features such as chute conveyance features. It has been postulated that a leading contributor was expansion of concrete due to solar radiation (see figure 4.8.6.1.4-1). Additionally, corrosion of exposed reinforcing bars at open CtJs may occur where splicing of the reinforcing bars may create a plane of weakness. As a possible fix, a surface blockout may be considered to reduce the potential for temperature-induced (thermal) expansion. However, care needs to be applied when considering the use of these blockouts (see figure 4.8.6.1.4-1).

**Design Standards No. 14: Appurtenant Structures for Dams
(Spillways and Outlet Works) Design Standards**

Delamination near slab surface due to solar radiation induced expansion of concrete.

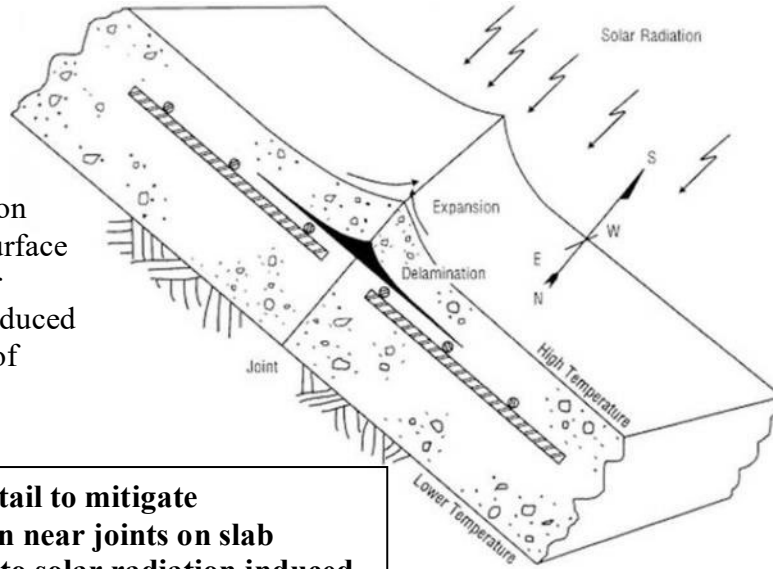

Alternative configuration would include square (rather than round) edges and sealant filled flush with flow surface.

Blockout detail to mitigate delamination near joints on slab surface due to solar radiation induced expansion of concrete. Limitations/considerations include:

- A temperature study should be used to identify significant surface expansion potential of the concrete.
- Adverse hydraulics, such as cavitation, could be exacerbated by the blockouts. For this reason, blockouts should only be considered when the average flow velocities are less than 50 ft/s (maximum flow velocity evaluated in laboratory testing).
- Filler material (sealant) should adhere to the sides of the blockout to limit potential accumulation of water and other material.
- Inspection and repair (if needed) should be undertaken on a periodic basis and after each significant operation of the outlet works (this effort could be significant in terms of time and cost to inspect and repair).

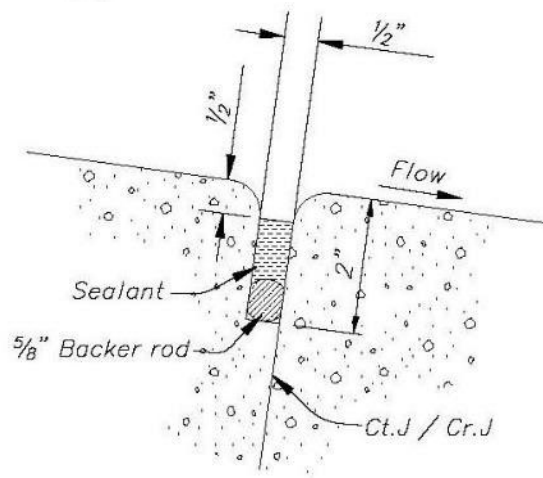

JOINT BLOCKOUT DETAIL

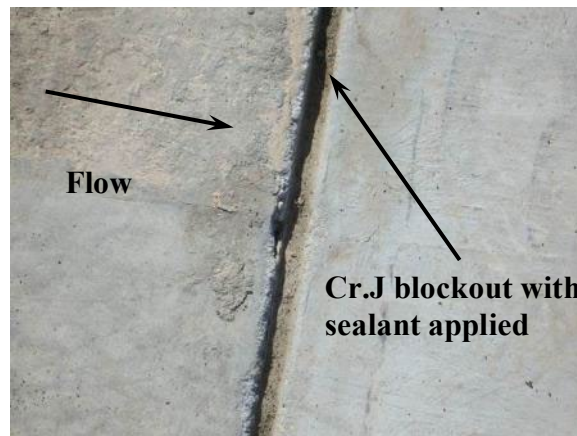

Cr.J blockout detail between existing inlet structure flow surface (floor) and new crest structure flow surface (floor), Echo Dam, UT.

Figure 4.8.6.1.4-1. Surface delamination near joints.

4.8.6.1.5 Expansion Joints

A fourth type of concrete joint used by Reclamation is the EJ, but it is seldom applicable to a reinforced concrete outlet works. Exceptions are EJs associated with outlet works access bridges, hoist decks, and non-water bearing walls. However, a brief discussion is provided for completeness. The EJs are separated, unbonded surfaces used to prevent stress or load transfer from one feature or structure to another adjacent feature or structure (see figure 4.8.6.1.5-1). Materials such as corkboard, mastic, sponge rubber, or other compressible-type fillers are used to fill the gap between the joint surfaces. The size of the gap and thickness of the compressible material will depend on the magnitude of the anticipated movement (deformation). Orientation of EJs is vertical. Also, the orientation of EJs tends to be either perpendicular or parallel to the centerline of the outlet works. An example is a bridge crossing over an outlet works terminal structure (hydraulic jump stilling basin) at a diagonal angle to the outlet works centerline. However, in this case, the EJs at both bridge abutments would be parallel to the centerline of the outlet works and diagonal to the orientation of the bridge. The location and spacing of EJs should be governed by the physical features of the outlet works, temperature study results, concrete placement methods, and the potential concrete placing capacity.

4.8.6.1.6 General Guidance for Selecting Joints

Table 4.8.6.1.6-1 summarizes the general guidance for identifying and locating joints.

As can be seen from table 4.8.6.1.6-1, both CrJs and CtJs have been, and can be, used for floor joints associated with a rock foundation. Some additional considerations (based on observations and experience) are summarized below, which relate to determining whether floor CrJs or CtJs should be used:

- Slabs with CrJs and CtJs are highly constrained (from movement) due to anchor bars and concrete-foundation cohesion. However, slabs with CtJs are more constrained given the continuous reinforcement that extends across the joint.

**Design Standards No. 14: Appurtenant Structures for Dams
(Spillways and Outlet Works) Design Standards**

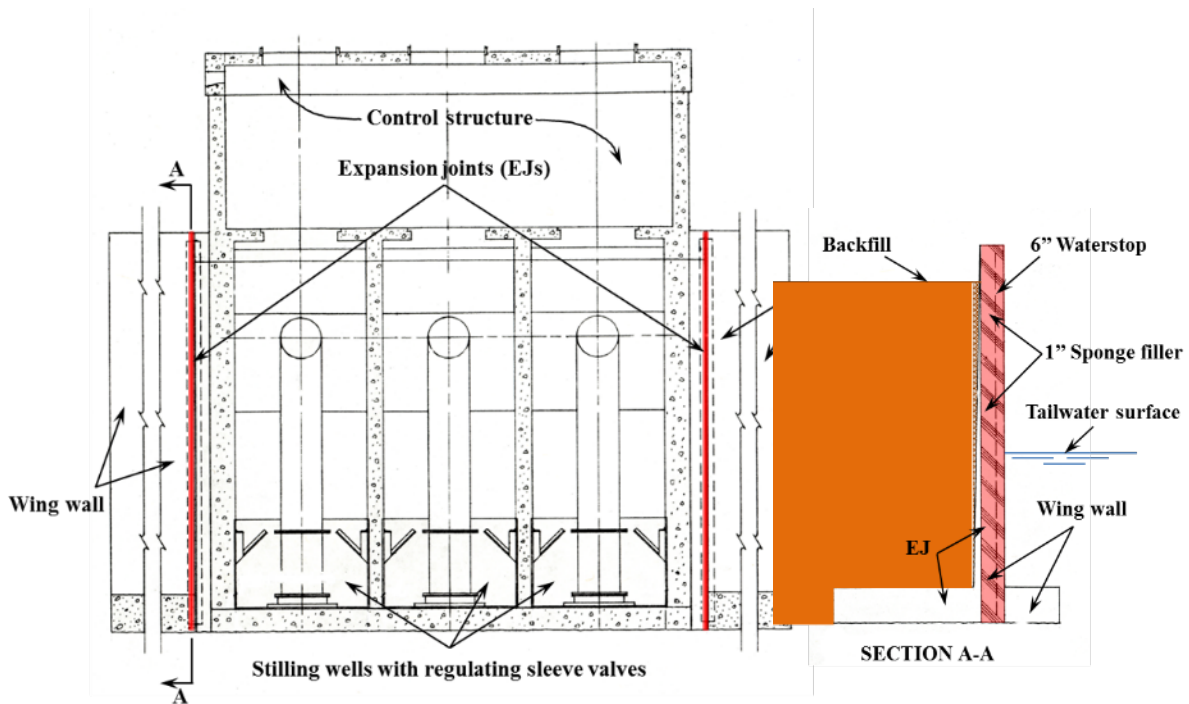

Sections of outlet works control structure and wing wall, which employ EJs at the interface between the control structure and the wing walls.

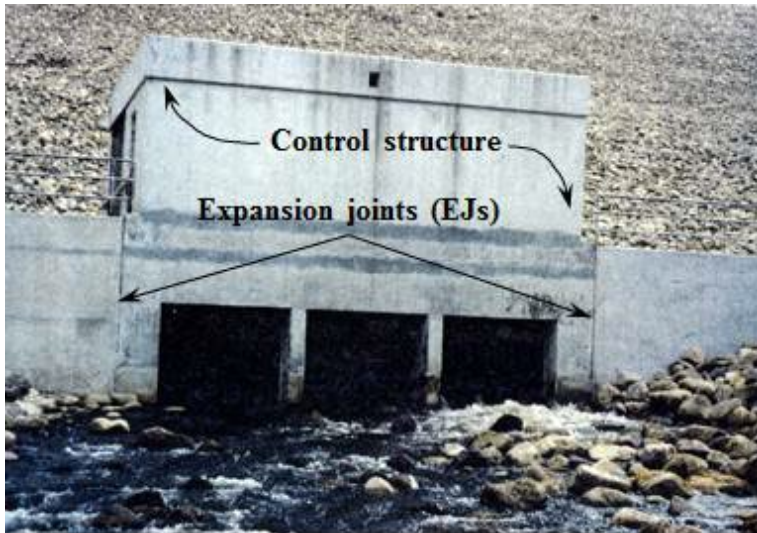

Figure 4.8.6.1.5-1. EJs.

Chapter 4: General Outlet Works Design Considerations

Table 4.8.6.1.6-1. Concrete Joints Associated with Outlet Works Features

Feature	Concrete joints			Comment
	CJ	CrJ	CtJ	
Intake structure:				
Walls	X	X		CJs horizontal, diagonal. CrJs vertical and include waterstops (exposed to water).
Floors (rock foundation)	X	X	X	CJs horizontal, vertical, diagonal. CrJs normal to flow surface, with plain dowels and waterstops (exposed to water). CtJs normal to flow surface and with waterstops (exposed to water).
Floors (soil foundation)	X		X	CJs horizontal, vertical, diagonal. CtJs normal to flow surface and with waterstops (exposed to water).
Control structure (gate chamber and shafts):				
Walls	X	X		CJs horizontal, diagonal. CrJs vertical and include waterstops (exposed to water).
Floors (rock foundation)	X	X	X	CJs horizontal, vertical, diagonal. CrJs normal to flow surface, with plain dowels and waterstops (exposed to water). CtJs normal to flow surface and with waterstops (exposed to water).
Floors (soil foundation)	X		X	CJs horizontal, vertical, diagonal. CtJs normal to flow surface and with waterstops (exposed to water).
Shafts	X			CJs horizontal, diagonal.
Grade control sill	X		X	CJs horizontal. CtJs normal to flow surface and with waterstops (exposed to water).
Chute:				
Walls	X	X		CJs horizontal, diagonal. CrJs vertical and include waterstops (exposed to water).
Retention walls	X		X	CJs horizontal, diagonal. CtJs vertical and with waterstops (exposed to water).

**Design Standards No. 14: Appurtenant Structures for Dams
(Spillways and Outlet Works) Design Standards**

Table 4.8.6.1.6-1. Concrete Joints Associated with Outlet Works Features

Feature	Concrete joints			Comment
	CJ	CrJ	CtJ	
Floors (rock foundation)	X	X	X	CJs horizontal, vertical, diagonal. CrJs normal to flow surface, with plain dowels and waterstops (exposed to water). CtJs normal to flow surface and with waterstops (exposed to water).
Floors (soil foundation)	X		X	CJs horizontal, vertical, diagonal. CtJs normal to flow surface and with waterstops (exposed to water).
Cutoffs (foundation)	X		X	CJs horizontal, vertical, diagonal. CtJs normal to flow surface and with waterstops (exposed to water).
Conduit:	X		X	CJs horizontal, diagonal. CtJs normal to flow surface and with waterstops (exposed to water).
Tunnel:	X		X	CJs horizontal, diagonal, and normal to flow surfaces, with or without waterstops. CtJs limited to tunnel interfaces with other components near the tunnel portals and control structures (such as gate chambers). Normal to flow surface and with waterstops (exposed to water).
Terminal Structure:				
Walls	X	X		CJs horizontal, diagonal. CrJs vertical and include waterstops (exposed to water).
Floors (rock foundation)	X	X	X	CJs horizontal, vertical, diagonal. CrJs normal to flow surface, with plain dowels and waterstops (exposed to water). CtJs normal to flow surface and with waterstops (exposed to water).
Floors (soil foundation)	X		X	CJs horizontal, vertical, diagonal. CtJs normal to flow surface and with waterstops (exposed to water).
Cutoffs (foundation)	X		X	CJs horizontal, vertical, diagonal. CtJs normal to flow surface and with waterstops (exposed to water).
Chute blocks, dentates, sills	X			CJs horizontal, diagonal.

- Although differential settlement potential associated with a rock foundation would be expected to be very small (compared to a soil foundation), consideration should be given to this possibility. A CtJ (with continuous reinforcement across the joint) tends to provide more capability to bridge localized foundation settlement than a CrJ (with or without plain dowels or formed concrete keys extending across the joint).
- Where there is the potential for large daily fluctuations in temperatures near the concrete surface (example: some southerly facing outlet works chute floor slabs can experience temperature changes of 70 °F or more), a CrJ may be a better choice than a CtJ. Also, as previously discussed in Section 4.8.6.1.4, “Surface Delamination near CrJs and CtJs,” in this chapter, expansion material may be considered if temperatures are expected to generate high compressive loads on the top surface of the concrete.

4.8.6.2 Waterstops

With very few exceptions, waterstops should be included with any flow surface CrJs and CtJs in slabs (floors), walls, and/or conduits/tunnels. This feature is an important defensive measure that helps mitigate adverse hydraulic conditions such as stagnation pressure potential (i.e., hydraulic jacking). Waterstops are seldom included with CJs or EJs; however, waterstops should be included in the rare case that an EJ is being used in an impoundment structure (i.e., structure retains the reservoir).

For new concrete (i.e., new concrete on either side of the joints), polyvinylchloride (PVC) ribbed with center bulb waterstops is included with flow surface CrJs and CtJs (see standard drawing 40-D-6463). General guidance for locating and sizing PVC waterstops includes:

- The overall width of the waterstop should not be greater than the thickness of the concrete slab, wall, or conduit/tunnel lining (i.e., if the slab is 1 foot thick, the waterstop width should be less than 12 inches, which would result in selection of one of the standard widths – either 6 or 9 inches).
- The size (overall width) of the waterstop is also based on the hydraulic head (hydrostatic and/or stagnation pressure). The design head for different waterstop sizes is specified by the manufacturer.
- The dimension from the concrete face or surface to the embedded waterstop must not be less than half the width of the waterstop (i.e., if the waterstop has a 9-inch width, the embedment dimension must be greater than or equal to 4.5 inches).

Design Standards No. 14: Appurtenant Structures for Dams (Spillways and Outlet Works) Design Standards

- The width of the waterstop must be at least six times the maximum sized aggregate (MSA) used in the concrete mix design (i.e., if the MSA is 1-½ inches, the waterstop must be at least 9 inches).

For the interface between existing and new concrete, “retrofit” (PVC) and/or “strip” (hydrophilic) waterstops are included with CrJs and CtJs (and some CJs) (i.e., for joints associated with most flow surfaces and where moisture could be an issue). Potential considerations associated with hydrophilic waterstops include: (1) installation temperature must be met; (2) ensure that there is sufficient concrete cover to mitigate the potential for waterstop expansion cracking the surrounding concrete; and (3) many wet-dry cycles over time could reduce expansion potential of the waterstop. Location and size of these retrofit and/or strip waterstops are specified by the designer of record (see figure 4.8.6.2-1, which illustrates applications of retrofit and strip waterstops).

4.8.6.3 Tolerances

Tolerances are the allowable concrete surface deviations of the constructed dimensions from the design dimensions [65, 66]. There are two types of tolerances, including structural deviations and surface tolerances or roughnesses. Structural deviations are associated with the line,⁵⁰ grade,⁵¹ length, width, and plumb⁵² requirements for a given structure (for additional information about structural deviations, refer to Reclamation’s standard guide specifications). The surface tolerances or roughnesses (T_s) define the limits of allowable surface irregularity such as bulges, depressions, and offsets (see figure 4.8.6.3-1 and table 4.8.6.3-1).

Furthermore, it should be pointed out that the surface tolerances or roughnesses are different than surface finishes⁵³ and must be specified separately (for additional information about finishes, refer to Reclamation’s standard guide specifications). The surface roughnesses that apply to outlet works are evaluated by identifying and measuring abrupt and gradual irregularities (see figure 4.8.6.3-2).

⁵⁰ Line deviation is the allowable structural variation in the horizontal placement (i.e., design alignment or station) of a structure.

⁵¹ Grade deviation is the allowable structural variation from the grade elevation (i.e., design elevation of slab, floor, etc.) of a structure.

⁵² Plumb deviation is the allowable structure variation from vertical and/or inclined surfaces (i.e., design vertical and/or battered surfaces such as walls, counterforts, etc.).

⁵³ Finishes result from surface texturing using specified methods to control surface blemishes. These finish methods could include steel troweling, sack rubbing, brooming, etc. Finishes are designated as either “F” for formed surfaces or “U” for unformed surfaces. For additional information, refer to Reclamation’s specifications guide paragraphs.

Chapter 4: General Outlet Works Design Considerations

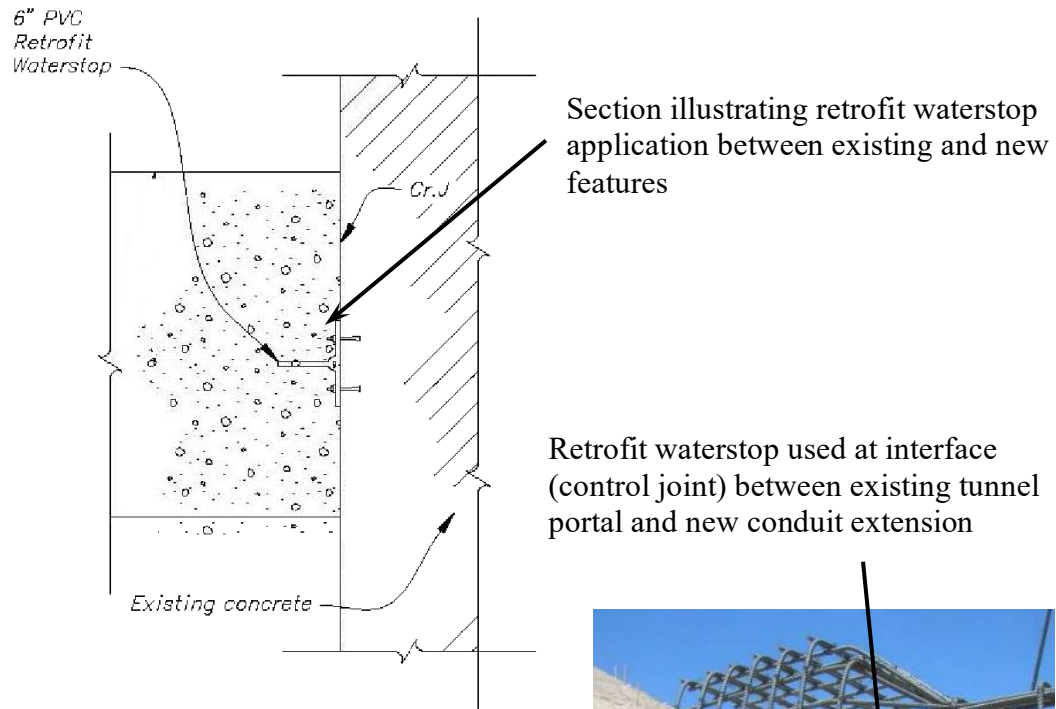

Figure 4.8.6.2-1. Retrofit and strip waterstops.

**Design Standards No. 14: Appurtenant Structures for Dams
(Spillways and Outlet Works) Design Standards**

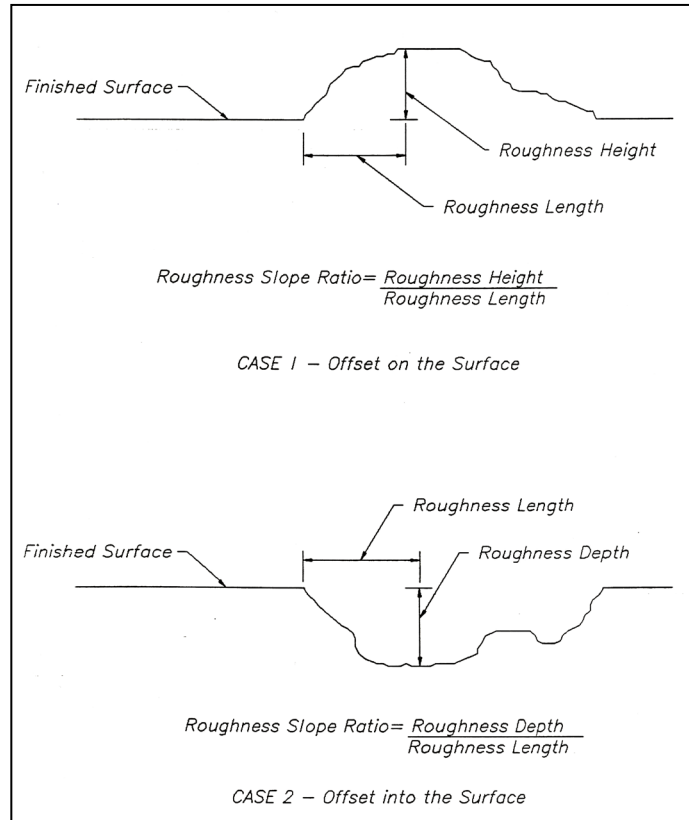

Figure 4.8.6.3-1. Surface roughnesses.

Table 4.8.6.3-1. Surface Tolerances (T_s)

Concrete Surface	Maximum Allowable Surface Irregularity Tolerance	
	Abrupt	Gradual
T1	1 inch	1/4 inch/inch
T2	1/2 inch	1/8 inch/inch
T3	1/4 inch	1/16 inch/inch
T4	1/8 inch	1/32 inch/inch
T5	1/32 inch	1/120 inch/inch

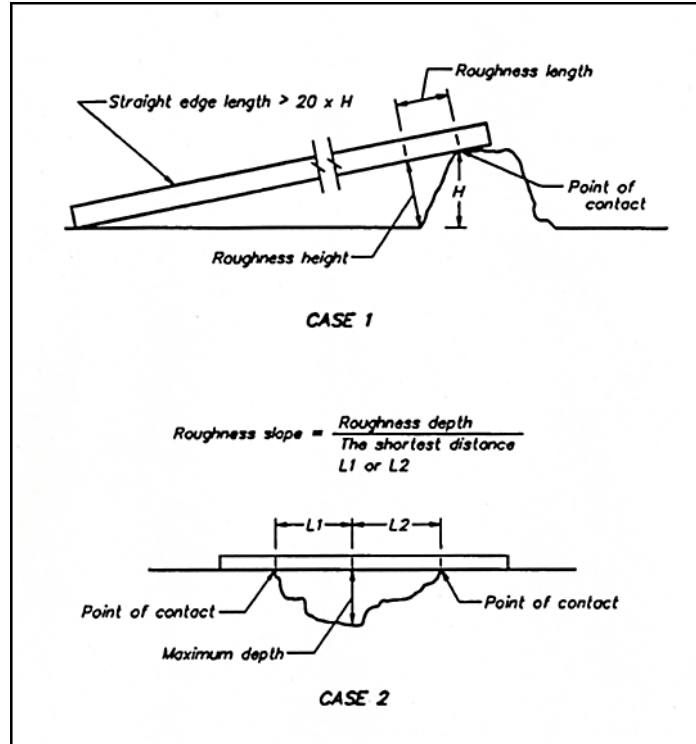

Figure 4.8.6.3-2. Measuring surface roughnesses.

4.8.6.3.1 Abrupt Irregularity

As a general rule, abrupt irregularity refers to isolated surface roughnesses in which the dimension of the irregularity perpendicular to the surface is greater than its dimension parallel to the surface. Although this definition still applies, it has been broadened to include all isolated surface deviations that exceed the gradual irregularity definition that follows in Section 4.8.6.3.2, “Gradual Irregularity,” in this chapter. Normally, these surface roughnesses are most critical on high velocity flow surfaces. A smooth flow surface that contains abrupt irregularities is more susceptible to cavitation damage. The abrupt irregularity guideline is the most restrictive guideline (compared to the gradual irregularity guideline) and should be evaluated first. The abrupt irregularity must be measured to determine if it exceeds the abrupt irregularity flow surface tolerance; if so, appropriate concrete repair in accordance with the *Guide to Concrete Repair* [66] may be warranted. Related to repair, it should be noted that contractors tend to prefer grinding concrete surfaces, rather than removing and replacing them, due to cost. However, grinding can result in greater potential for eventual aggregate pop-out, which will create abrupt irregularities.

4.8.6.3.2 Gradual Irregularity

This is commonly referred to when describing isolated undulations in the concrete surface. The dimension of the roughness normal to the concrete surface is small relative to its dimension parallel to the concrete surface. Gradual irregularities are

Design Standards No. 14: Appurtenant Structures for Dams (Spillways and Outlet Works) Design Standards

generally less critical than abrupt irregularities. Therefore, the maximum allowable depth (dimension perpendicular to the surface) of a gradual irregularity may be greater than the allowable abrupt surface tolerance. However, the maximum allowable gradual irregularity is limited by the controlling structural deviation (i.e., line or grade). As with the abrupt irregularity, the gradual irregularity must be measured to determine if it exceeds the gradual irregularity flow surface tolerance; if so, appropriate concrete repair in accordance with the *Guide to Concrete Repair* [66] may be warranted.

4.8.6.3.3 Surface Roughness and Cavitation Potential

As previously discussed in Section 4.6.4.2, “Conveyance Features Hydraulics,” in this chapter, surface tolerances or roughnesses (T_S) have been correlated to cavitation index of flow (σ). The following bullets summarize typical flow surface roughnesses applicable to cavitation index of flow values:

- If $\sigma \geq 0.5$, cavitation potential is diminished, but it is important that an appropriate flow surface roughness be achieved to minimize potential. This is done by specifying a $T3$ flow surface roughness (abrupt offset $\leq 1/4$ inch and gradual offset of 1 to 16 or flatter).
- If $0.5 > \sigma > 0.2$, provide a specified surface roughness, which is either a $T3$ flow surface roughness (abrupt offset $\leq 1/4$ inch and gradual offset of 1 to 16 or flatter) or $T4$ flow surface roughness (abrupt offset $\leq 1/8$ inch and gradual offset of 1 to 32 or flatter).
- If $\sigma \leq 0.2$, provide air entrainment (i.e., constructing an aeration ramp or slot) for existing and new outlet works or redesign (realign) for new outlet works. For more details, refer to Engineering Monograph No. 42, *Cavitation in Chutes and Spillways* [31].

4.8.6.3.4 Surface Roughness and Other Factors

In addition to considering the cavitation indices, other factors must be included in the final selection of the flow surface roughnesses or tolerances:

- Hydraulic head losses (due to excessive flow surface irregularities or tolerances) could be detrimental, resulting in power loss due to high friction losses in a pressurized conveyance feature (i.e., tunnel and/or conduit).
- Construction concerns (can a specified flow surface roughness be reasonably attained by the contractor?).

Chapter 4: General Outlet Works Design Considerations

- Operation and maintenance (O&M) concerns (potential for increased surface roughening over time). While surface damage caused by freeze-thaw cycles can be minimized by using air-entrained concrete, it may not be fully eliminated. Also, in conveyance features, such as tunnels and chutes, exposed to ground water, surface deposits can accumulate through cracks, due to seepage. It can be very difficult and expensive to maintain surface tolerances or roughnesses if they are too strict.

- Aesthetic concerns (public perception of visible portions of the structure).

4.8.6.3.5 Design Procedure for Selecting Surface Tolerances

The following design approach (table 4.8.6.3.5-1) summarizes the steps in selecting surface tolerances or roughnesses.

For additional guidance about selecting surface roughnesses associated with nonflow surfaces, refer to Reclamation’s guide specifications.

Table 4.8.6.3.5-1. Procedure for Selecting Surface Tolerances (TS)

Step 1 (Initial outlet works layout)	Lay out the preliminary design configuration of the outlet works, considering the alignment and profile. Hydraulically size the outlet works to pass the maximum design flows (typically includes flood routings, along with water surface profile and cavitation indices profile analyses).
Step 2 (Hydraulics – cavitation potential)	Evaluate the cavitation indices profile results, which should include a suite of cavitation indices profiles associated with a range of flows (up to the maximum design flow) anticipated to be passed by the outlet works. Note that the critical cavitation indices condition (smallest cavitation indices) may be associated with flows less than the maximum design flows.
Step 3 (Flow surface roughness)	Based on the correlation between cavitation indices and flow surface roughnesses, identify the flow surface tolerances. This should be based on the minimum value of the cavitation indices profiles.
Step 4 (If cavitation indices < 0.2, repeat steps 1-3)	If there are any cavitation indices less than 0.2, repeat steps 1 through 3 to evaluate what effects might result on the cavitation indices by changing the geometry (alignment and/or profile) of the outlet works and/or consider other types of outlet works components.
Step 5 (If cavitation indices < 0.2, aeration ramps/slots)	If the cavitation indices cannot be reasonably increased (greater than 0.2) by changing the geometry or type of outlet works or changing the components, consider including an aeration ramp or slot.
Step 6 (Nonhydraulic factors)	Evaluate other factors that could influence the selection of the flow surface tolerances for the outlet works. As an example, these factors could drive a T3 flow surface tolerance (based on cavitation indices) to a T4 flow surface tolerance (based on O&M concerns, can the surface roughness or tolerance be maintained over time at reasonable expenses?) or a T5 flow surface tolerance (based on aesthetic concerns). Also, T1 and T2 nonflow surfaces (based primarily on hidden or buried surface conditions) might be applicable.

4.9 General Electrical/Mechanical Considerations

This section provides general electrical/mechanical considerations for determining the type, location, and size of a modified or new outlet works. Detailed electrical/mechanical analysis and design can be found in Chapter 7, “Electrical/Mechanical Considerations for Spillways and Outlet Works,” of this design standard.

As previously noted, unless specified otherwise, this chapter is applicable to the evaluation, analysis, and design of reinforced concrete, high velocity, and high flow outlet works.

4.9.1 Mechanical Features

Existing and new outlet works will normally include mechanical features such as gates, valves, and bulkheads or stoplogs. These mechanical features are critical for safe and reliable operation and to facilitate maintenance of the outlet works.

4.9.1.1 Gates and Valves

In speaking or writing of devices for controlling or regulating the flow of water through an outlet in a dam, the words “gate” and “valve” are used. Some confusion exists as to whether the distinction between gate and valve should be based on function or design. The term “gate,” unless qualified as a regulating gate, shall be understood to mean a controlling device which is designed and used principally to allow the passage of the full capacity of an outlet or to shut it off completely; that is, it is only designed to be operated in the fully open or fully closed positions. No throttling or controlling of the flow is allowed.

The term “regulating gate” is used to designate a gate which performs the function of a valve. An example of a regulating gate is the “jet-flow gate.” A jet-flow gate functions similar to other “valves,” such as a sleeve valve or a fixed cone valve. These types of valves are used to vary the flow at the downstream end of a dam outlet. The requirements introduced by the necessity of operating a gate under emergency conditions (i.e., the “emergency closing gate” of a dam), which must be accommodated in a design, do not alter the primary function. A gate is predominantly in a fully closed or fully opened position.

The term “valve” will be used to designate a controlling device designed primarily for the purpose of regulating the amount of flow through an outlet from 0 ft³/s to its maximum designed discharge; therefore, it is a requirement that it be operated at partially opened positions, and this requirement is largely the

Chapter 4: General Outlet Works Design Considerations

controlling factor in its design. It is also common for a valve to be used as the isolation valve (sometimes referred to as the "guard valve") for various suboutlets that can be connected from the main outlet of a dam.

A wide range of gates and/or valve types and sizes have been used, and are being used, as controls in Reclamation outlet works. The regulating gate and/or valve selection depends on their location, the waterway configuration upstream and downstream, the function of the gate and/or valve, O&M considerations, replacement considerations, size (within ranges of sizes that are available or have been designed), head loss restrictions, design head, loading (balanced or unbalanced head), and requirements for the regulation of discharge (i.e., gate/valve open, closed, full range of operation).

Of note is the gate or valve size, where the required discharge may be associated with a nonstandard gate size. In this case, a larger standard gate size may be used, which could result in larger outlet works discharge capacities than required or in requiring a gate or valve to be operated with a restriction (i.e., limit gate or valve opening). In addition to selecting a type and size for the regulating gate and/or valve, the designer must consider the requirements for additional gates and/or valves for emergency or guard use.

It is Reclamation's practice to provide a means for regulating gate/valve maintenance, repair and, in some cases, replacement. Table 4.9.1.1-1 summarizes the gates and/or valves that have been used at Reclamation's outlet works [67, 68]. While the gates and valves listed in table 4.9.1.1-1 have been used in Reclamation outlet works, several types are no longer being used for new construction. For a detailed discussion of the gates and valves, see Chapter 5, "Gates," and Chapter 7, "Valves," of *Design Standards No. 6 - Hydraulic and Mechanical Equipment*. An additional reference is "Selection of Outlet Works Gates and Valves." [69]

Some of the gates and/or valves used to control Reclamation's outlet works are illustrated by figures 4.9.1.1-1 through 4.9.1.1-18.

**Design Standards No. 14: Appurtenant Structures for Dams
(Spillways and Outlet Works) Design Standards**

Table 4.9.1.1-1. Gates and Valves Used in Outlet Works

Gate/Valve Type	Use		Size	Maximum Head	Comment
	Regulate	Guard or Emergency			
Ball valve		X	1 to 60 inches	750 feet	
Butterfly valve	X	X	4 to 168 inches in diameter	750 feet	Mostly guard applications (not suggested to be used for regulating applications).
Clamshell gate	X		30 to 78 inches in diameter	300*	Very high discharge coefficient (0.98).
Cylinder gate	X	X		500*	
Ensign valve	X		58 to 60 inches in diameter	300	Located on upstream end of outlet works; submerged in reservoir.
Fixed-cone valve	X		8 to 132 inches in diameter	See comment	Sometimes referred to as Howell-Bunger valve. Up to 900 feet of head for smaller valves and up to 420 feet of head for larger valves.
Fixed-wheel gate		X	7.74 by 7.74 feet to 29 by 43.5 feet	700 feet	Sometimes referred to as wheel-mounted gate.
Gate valve	X	X	2 to 66 inches in diameter	300 feet	
Hollow-jet valve	X		24 to 96 inches in diameter	1,000 feet	
Jet-flow gate	X		6 to 96 inches in diameter	500 feet	Early versions of jet-flow gates, such as those used at Shasta Dam, were called outlet gates, which are not the same as the outlet gates that are presently used.

Chapter 4: General Outlet Works Design Considerations

Table 4.9.1.1-1. Gates and Valves Used in Outlet Works

Gate/Valve Type	Use		Size	Maximum Head	Comment
	Regulate	Guard or Emergency			
Needle valve	X	X	10 to 168 inches in diameter	700 feet	Water-operated valves have been replaced at Reclamation facilities (smaller mechanically operated needle valves are still in use and are generally about 24 inches in diameter).
Outlet/high pressure gate (similar to bonneted slide gate)	X	X	2.75 by 2.75 feet to 9 by 12 feet	See footnote	A high pressure gate is a cast iron gate with less than 250 feet of head. An outlet gate is a welded steel gate with less than 250 feet of head.
Paradox gate		X	86 to 102 inches in diameter	600 feet	Similar to ring-follower and ring-seal gates.
Ring-follower gate		X	30 to 102 inches in diameter	500 feet	Similar to paradox and ring-seal gates.
Ring-seal gate		X	30 to 102 inches in diameter	300 feet	Similar to paradox and ring-follower gates.
Roller-mounted gate		X	15 by 30 feet to 50 by 55 feet	700 feet	Variations of this gate are stoney, caterpillar, tractor, and coaster gates.
Sleeve valve	X		8 to 54 inches in diameter	1,310 feet	
Slide gate					
Bonneted	X	X	72 by 108 inches to 120 by 240 inches	500 feet	Virtually the same as an outlet gate.
Unbonneted	X	X	6 by 6 inches to 144 by 144 inches	150 feet	
Top-seal radial gate	X		50 by 64 feet	250 feet	
Tube valve		X	36 to 96 inches in diameter	300 feet	

* Maximum hydraulic head estimates are based on experience, but they do not represent a physically maximum number.

**Design Standards No. 14: Appurtenant Structures for Dams
(Spillways and Outlet Works) Design Standards**



Figure 4.9.1.1-1. Butterfly valve.



Figure 4.9.1.1-2. Clamshell gate.

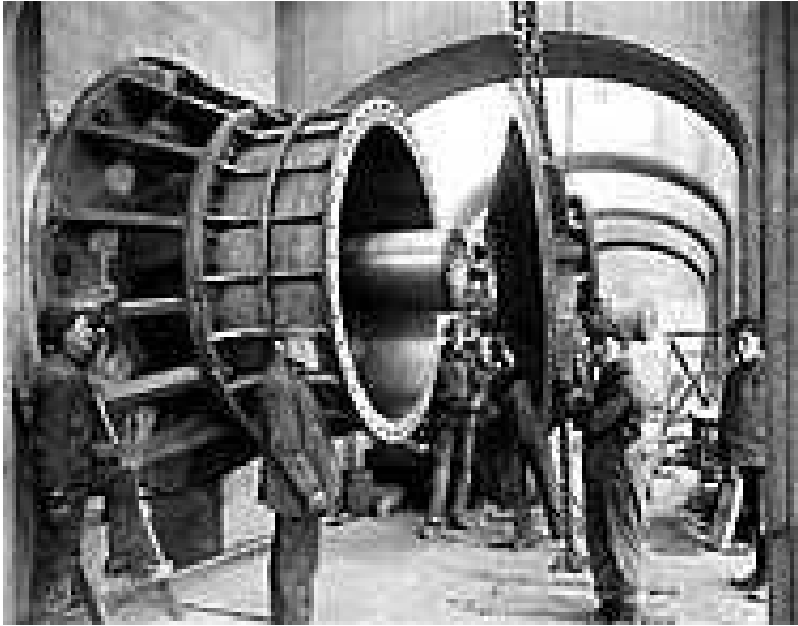

Figure 4.9.1.1-3. Ensign valves.

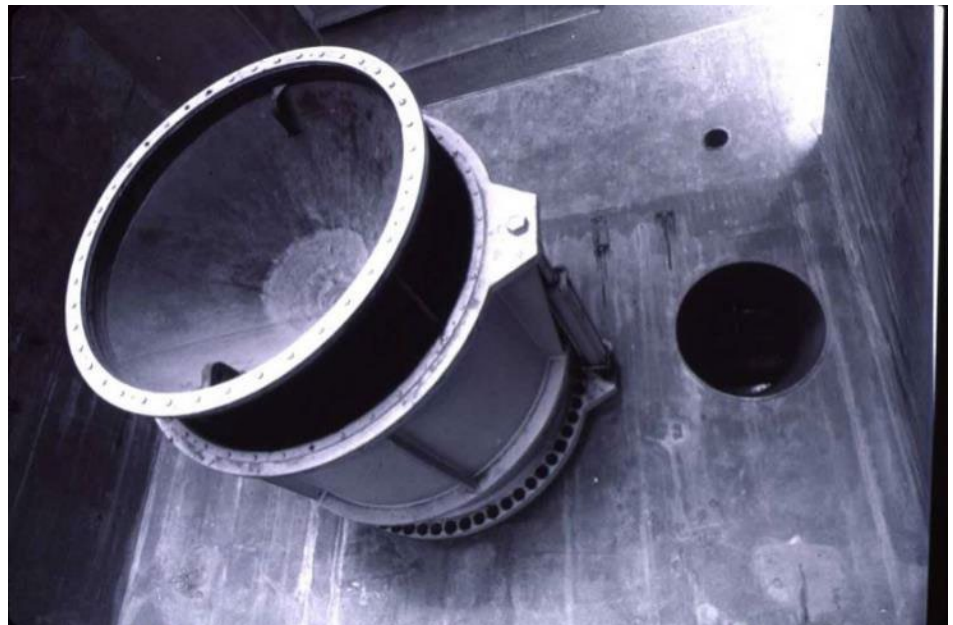

Figure 4.9.1.1-4. Fixed-cone valve or Howell-Bunger valve.

**Design Standards No. 14: Appurtenant Structures for Dams
(Spillways and Outlet Works) Design Standards**

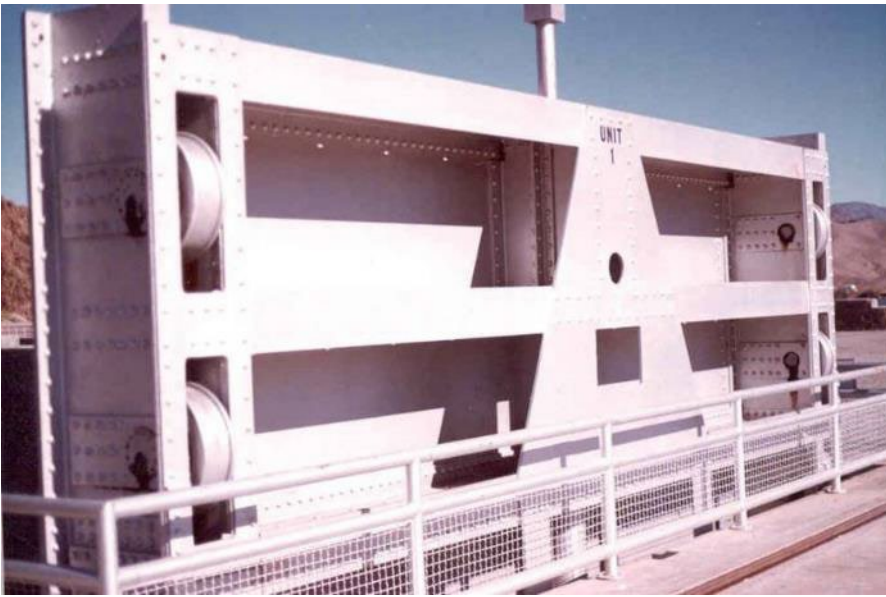

Figure 4.9.1.1-5. Fixed-wheel gate or wheel-mounted gate.



Figure 4.9.1.1-6. Gate valve.

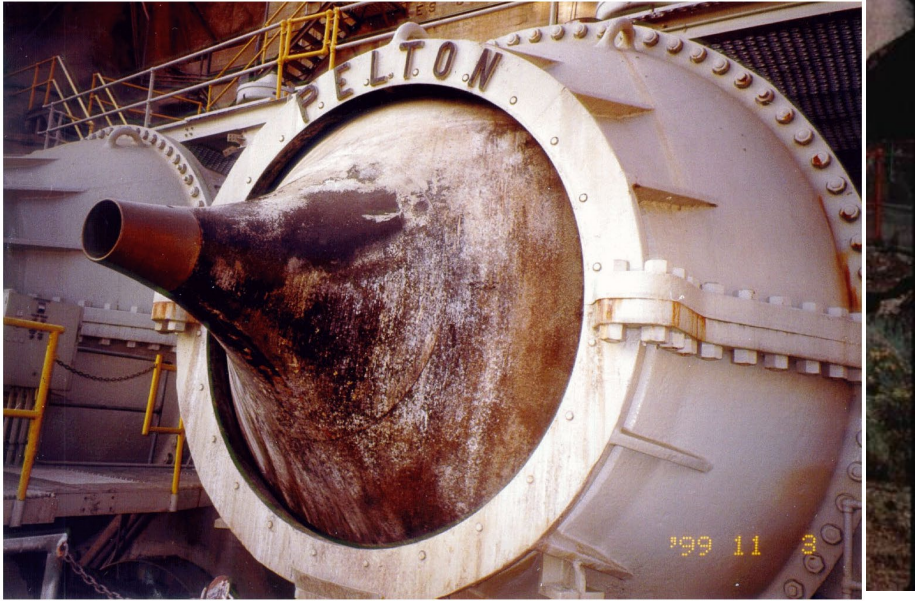

Figure 4.9.1.1-9. Needle valve.



Figure 4.9.1.1-10. Outlet gate.

**Design Standards No. 14: Appurtenant Structures for Dams
(Spillways and Outlet Works) Design Standards**

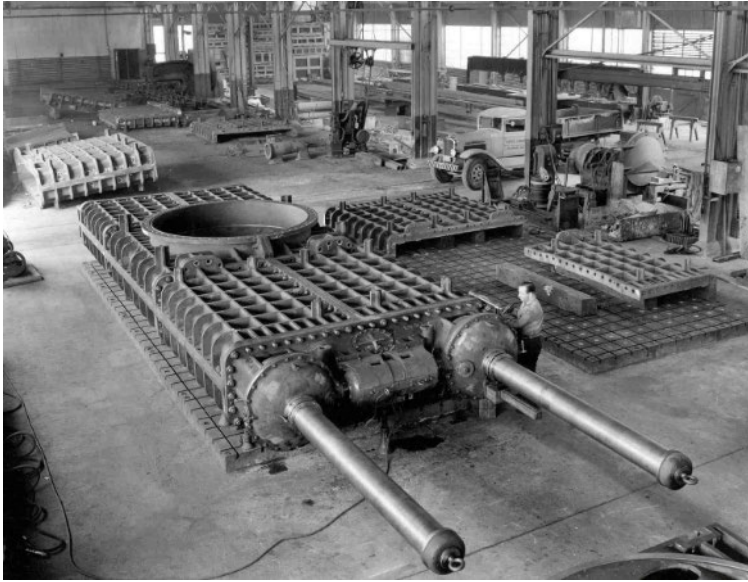

Figure 4.9.1.1-11. Paradox gate.



Figure 4.9.1.1-12. Ring-follower gate.

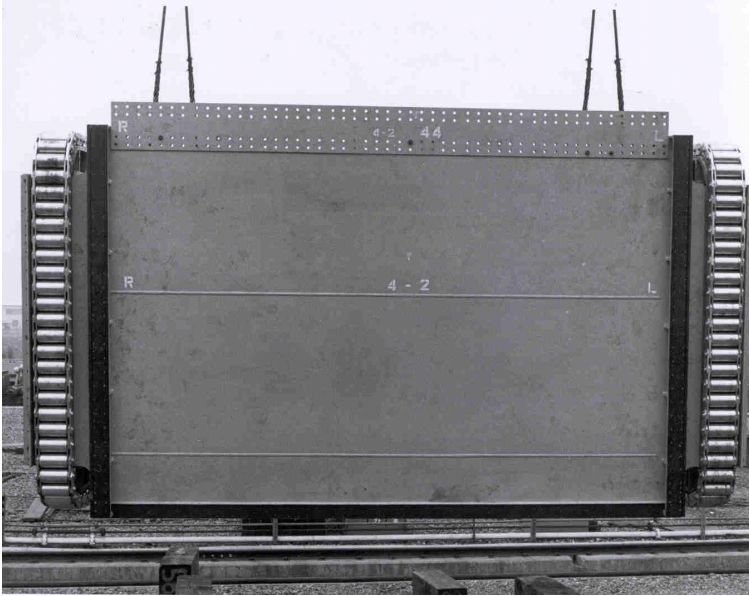

Figure 4.9.1.1-13. Roller-mounted gate, similar to caterpillar, tractor, and coaster gates.



Figure 4.9.1.1-14. Ring-seal gate.

**Design Standards No. 14: Appurtenant Structures for Dams
(Spillways and Outlet Works) Design Standards**



Figure 4.9.1.1-15. Sleeve valve.



Figure 4.9.1.1-16. Top-seal radial gate.



Figure 4.9.1.1-17. Unbonneted slide gate.

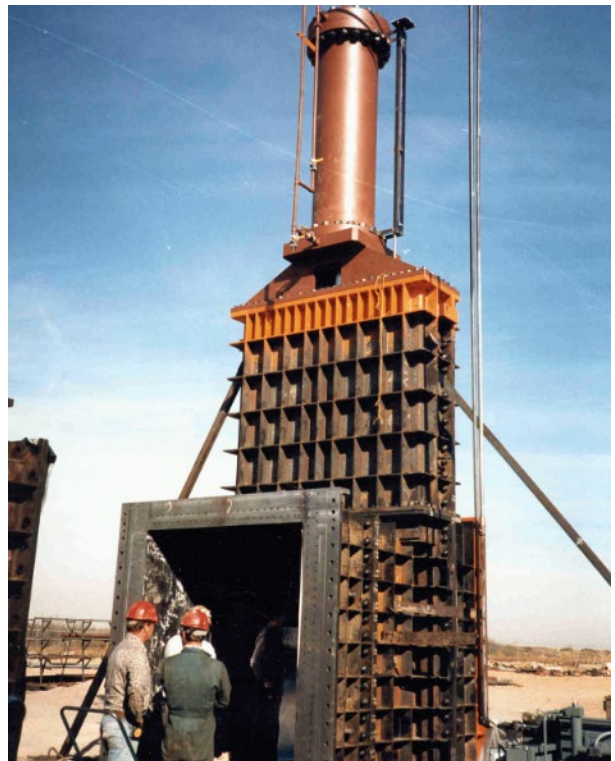

Figure 4.9.1.1-18. Bonneted slide gate.

**Design Standards No. 14: Appurtenant Structures for Dams
(Spillways and Outlet Works) Design Standards**

4.9.1.2 Air Venting for Gates and Valves

Air vents are connected to the downstream sides of guard/emergency and regulating gates and valves when they are discharging into a confined space (such as pipes, conduits, or tunnels) or partially submerged. Air vents provide the air necessary to prevent development of significant negative pressure, which could cause cavitation damage or water column separation, which could then result in destructive pressure waves, leading to damage or collapse of the pipe. Air vents are also used to vent air during filling of pressure pipes, conduits, or tunnels [68]. For additional information and/or guidance, see Chapter 5, “Hydraulic Design Considerations for Spillways and Outlet Works,” of this design standard.

4.9.1.3 Bulkheads

Bulkheads are mechanical features used to isolate the downstream outlet works (including regulating gates or valves) from the reservoir or from tailwater, which is done to facilitate maintenance operations and inspection of normally inundated portions of the outlet works [70]. The bulkhead is a flat, structurally reinforced gate leaf with rubber seals, which comes in various shapes and sizes to fit a particular control structure. The bulkhead normally fits into vertical gate slots or tracks and guides for horizontal flow entry type intake structures, such as a box intake structure (rectangular), or it is located on top of vertical entry type control structures, such as a drop inlet control structure (circular) (see figure 4.9.1.3-1). Bulkheads are single piece units used when the entrance is submerged, which is typically the case for outlet works. Installation and removal are usually accomplished by gantry or mobile crane, barge-mounted crane, and some very large bulkheads are designed to be floated into place (with diver assistance).

Note: For almost all bulkhead installations, balanced⁵⁴ head conditions must be maintained. Bulkheads are not intended for emergency closure. For submerged control structures, the bulkheads must be equipped with a filling line and, in some instances, with an air vent. The majority of outlet works in Reclamation’s inventory have slots and/or seals to accommodate bulkheads. The largest circular bulkhead is 20 feet in diameter. Maximum hydraulic heads range from 300 to 400 feet. The amount of leakage associated with a bulkhead is usually determined by the condition of the slots or the seals.

Design considerations include recognizing that the span or width of a bulkhead is limited by deflection, crane capacity, and site delivery limitations. Bulkheads, or at least gate slots, should be part of an outlet works design where it may not be possible to lower the reservoir to elevations approaching the outlet works intake structure sill on an as-needed basis. Structures to be unwatered must be designed for the loading condition.

⁵⁴ The term “balanced head conditions” refers to equal pressure on the upstream and downstream sides of the bulkhead during installation and removal.

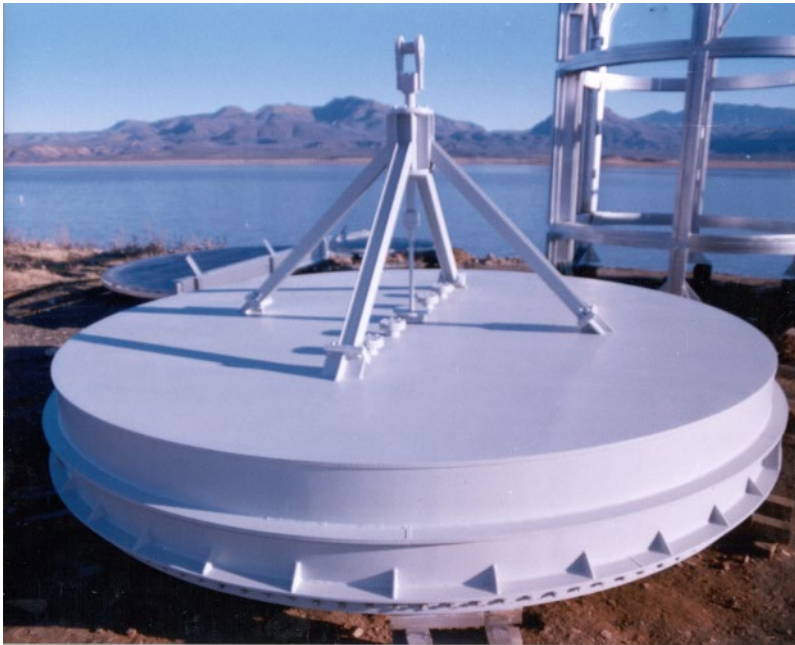

Metal circular bulkhead for drop inlet outlet works

Metal bulkhead for outlet works ring-seal gate



Figure 4.9.1.3-1. Bulkheads.

In some cases, consideration should be given to including bulkhead slots and bulkheads for the terminal structure (such as a hydraulic jump stilling basin) where periodic unwatering of the terminal structure may be required. Such an application would typically only be feasible and/or cost effective for a relatively narrow terminal structure in the range of 30 feet or less. As a reminder, if there will be a need to unwater the terminal structure, design considerations will

Design Standards No. 14: Appurtenant Structures for Dams (Spillways and Outlet Works) Design Standards

include ensuring floatation stability of the unwatered terminal structure subject to normal tailwater conditions (see Section 4.8.3, “Stability Design,” in this chapter for more details).

An additional design consideration is to share a single bulkhead between multiple outlets at a single dam or between multiple dams. One advantage of sharing a bulkhead is the lower fabrication and storage costs. It will be necessary to consider the design requirements for using an existing bulkhead in a new outlet works. A shared bulkhead will also require coordination for scheduling and transporting to a given outlet or dam.

4.9.1.4 Stoplogs

Stoplogs have a purpose similar to bulkheads. A stoplog is a mechanical feature used to unwater a portion of the outlet works to facilitate maintenance operations and inspect normally inundated portions of the outlet works [70]. Stoplogs consist of individual beams, girders, or multiple beams and plates welded together to make one stoplog. Stoplogs are set one upon the other to form a watertight barrier supported by gate slots for a horizontal flow entry type intake structure (see figure 4.9.1.3-1). Stoplogs are typically used when the entrance to the intake and/or control structure is not submerged or at the downstream end of a terminal structure (such as a hydraulic jump stilling basin). Because outlet works intake structures are typically submerged, use of stoplogs rather than bulkheads is limited (such as using stoplogs to support diversion during construction when the reservoir has not begun to fill or is at a very low stage).

As previously noted for bulkheads, installing and removing stoplogs at the downstream end of a terminal structure would typically only be feasible and/or cost effective for a relatively narrow terminal structure in the range of 30 feet or less. Also, stoplogs are not intended for emergency closure. Stoplog installation and removal usually take place by gantry or mobile crane and barge-mounted crane. Note: For all stoplog installations, balanced head conditions must be maintained.

If the terminal structure will need to be unwatered, design considerations will include ensuring (floatation) stability of the unwatered terminal structure subject to normal tailwater conditions (For more details, see Section 4.8.3, “Stability Design,” in this chapter).

As with bulkheads, stoplogs may be designed to be shared between multiple outlets at a single dam or between multiple dams.

4.9.2 Operating Systems

Operating systems for gates and/or valves are either manual or automatic. Details of the operating system will vary with the type of gates and/or valves and type of

hoisting and operating equipment. Outlet works gates and/or valves can be operated by gear screw lifts, stems, hydraulic hoists, electrically powered mechanical hoists with wire ropes or chains connected to the gates, or by hydraulically using floats and wire ropes. Additional considerations include:

- Geared screw lifts are used on many small- to large-sized gates and valves.
- Hydraulic hoists and operators are used for large, high-head gates and valves because of their hoisting and operating capacities, simple design, and ease of flexibility of control. Also, hydraulic hoists and operators are used when gates or valves are operated frequently.
- Electrical operating systems can be used with geared screw lifts or hydraulic hoists. Present practice favors electrically operated mechanical hoists and operators because of cost and reliability factors.

It is very important to have a backup or auxiliary power system (such as an engine-generator) to operate the outlet works gates and/or valves under unexpected or emergency conditions. Periodic inspection, maintenance, and testing requirements should be part of the design [67, 68]. Also, manual operators have been included on some gates as an additional backup. It can take a long time and exhaust operating personnel to open a gate unassisted using manual controls. A portable power tool can provide assistance.

4.10 Instrumentation and Monitoring

Reclamation's design approach for instrumentation and monitoring of dams does not focus on minimum instrumentation requirements. Instead, instrumentation and monitoring needs are determined for each dam and its appurtenant structures on a case-by-case basis. For the most part, instrumentation and monitoring needs are based on monitoring and detecting key parameters (such as cracking or movement of outlet works walls, floors, conduits/tunnels, and/or towers) that would indicate initiation or progression of PFMs. This effort can include both data collection via instrumentation and periodic visual inspection, which is based on a site-specific Ongoing Visual Inspection Checklist (OVIC). Common instrumentation for outlet works includes structural measurement points, crack meters, and seepage measurement weirs.

There are a few exceptions⁵⁵ in which instrumentation and monitoring may be based on the category of "general health monitoring," which is not associated

⁵⁵ Most common examples are structural measurement points placed on or embedded in outlet works walls and towers, which are initially surveyed; then, measurement points are put on standby status until a future event occurs (such as an earthquake) that may damage the structure, prompting another survey to determine any changes from the initial survey.

Design Standards No. 14: Appurtenant Structures for Dams (Spillways and Outlet Works) Design Standards

with any specific PFM. Such instrumentation and monitoring almost always is “high-value, low-cost.” Determining what does and does not represent appropriate “general health monitoring” is a continuing challenge when defining dam safety monitoring programs.

For Reclamation storage and multipurpose dams, the instrumentation and monitoring program is defined in the Schedule for Periodic Monitoring (L-23), which summarizes the routine dam safety monitoring program and presents required monitoring in the event of unusually high reservoir levels and/or significant seismic shaking.

For evaluating and/or developing an instrumentation and monitoring program for an existing or new outlet works, some coordination and consideration of the instrumentation and monitoring program for the existing or new dam must be included in the design. In this case, refer to *Design Standards No. 2, “Concrete Dams [3],”* and *Design Standards No. 13, “Embankment Dams [4].”*

4.11 Technical References

Reclamation's technical references associated with analyzing and designing outlet works include:

- *Reclamation Manual – Design Data Collection Guidelines [10].*
- *Design of Small Dams, third edition [5].*
- *Best Practices in Dam and Levee Safety Risk Analysis [9].*
- *Estimate Worksheet – Guide for Designers [11].*
- *Design of Small Canal Structures [18].*
- *Design of Spillways and Outlet Works for Dams – Design Manual, Part 1, General Considerations [19].*
- *EM No. 14 – Beggs Deformeter Stress Analysis of Single Barrel Conduits [20].*
- *ACER TM No. 9 – Guidelines for Seepage along Conduits through Embankment Dams [24].*
- *ACER TM No. 3 – Criteria and Guidelines for Evacuating Storage Reservoirs and Sizing Low-Level Outlet Works [28].*

Chapter 4: General Outlet Works Design Considerations

- *EM No. 42 – Cavitation in Chutes and Spillways* [31].
- *EM No. 41 – Air-Water Flow in Hydraulic Structures* [32]
- *DSO-07-07 – Uplift and Crack Flow Resulting from High Velocity Discharge Over Offset Joints* [34].
- *EM No. 25 – Hydraulic Design of Stilling Basins and Energy Dissipators* [35].
- *Research Report No. 24 – Hydraulic Design of Stilling Basin for Pipe or Channel Outlets* [36].
- *Computing Degradation and Local Scour* [38].
- *Engineering Geology Field Manual, Volume 1* [44]
- *Guideline for Performing Foundation Investigation for Miscellaneous Structures* [45].
- *Design of Spillways and Outlet Works for Dams – A Design Manual, Part II, Volume II* [47].
- *Engineering Geology Field Manual, Volume 2* [49].
- *REC-ERC-82-17, Frost Action in Soil Foundations and Control of Surface Structure Heaving* [51].
- *Drainage for Dams and Associated Structures Manual* [52].
- *Design Criteria for Concrete Retaining Walls* [55].
- *Interim Dam Safety Public Protection Guidelines* [29].
- *Position Paper – Detailed Concrete Reinforcement Design Drawings* [61].
- *TM No. TSC-8100-Standards-2016-1, Standard Drawings 40-D-60003 and 40-D-60004, Revision 0, Background and Development* [63].
- *Standard STD-8130-1, Working Document – Detailed Reinforcement Drawing Guidelines* [64].
- *Concrete Surface Tolerances, Finishes, and Curing Reference Material* [65].

Design Standards No. 14: Appurtenant Structures for Dams (Spillways and Outlet Works) Design Standards

- *Guide to Concrete Repair* [66].
- *Gates and Valves – Working Document* [67].
- *Guidelines for Safety Evaluation of Mechanical Equipment* [68].
- *ACER TM No. 4 – Criteria for Bulkheading Outlet Works Intakes for Storage Dams* [70].
- *Memorandum – Analysis of Additional Conduit Shapes* [21].

4.12 References

- [1] *Reclamation Manual, Directive and Standards*, “Design Activities,” Bureau of Reclamation, January 2008.
- [2] Chapter 3, “Diversion Dam and Headworks,” of *Design Standards No. 3 – Water Conveyance Facilities, Fish Facilities, and Roads and Bridges*, Bureau of Reclamation (in progress).
- [3] *Design Standards No. 2 – Concrete Dams*, Bureau of Reclamation, 1977.
- [4] *Design Standards No. 13 – Embankment Dams*, Bureau of Reclamation (one still in progress).
- [5] *Design of Small Dams*, third edition, Bureau of Reclamation, 1987.
- [6] *Quenching the Thirst: Sustainable Water Supply and Climate Change*, G.W. Annandale, CreateSpace, 2013.
- [7] *Final Design Process Guidelines*, Bureau of Reclamation, December 2017.
- [8] *Safety of Dams, Project Management Guidelines*, Bureau of Reclamation, January 2018.
- [9] *Best Practices in Dam and Levee Safety Risk Analysis*, Bureau of Reclamation and U.S. Army Corps of Engineers, 2018.
- [10] *Reclamation Manual, Directives and Standards*, “Design Data Collection Guidelines,” Bureau of Reclamation, September 2007.
- [11] “Estimate Work Sheet – Guide for Designers,” Bureau of Reclamation, April 2010.

Chapter 4: General Outlet Works Design Considerations

- [12] *Sedimentation Engineering*, Manual 110, Chapter 12, M.H. Garcia, ASCE, 2008.
- [13] *Managing Sediment in Utah's Reservoirs*, Utah Division of Water Resources, 2010.
- [14] Technical Memorandum: *Preliminary Evaluation of Sediment Mitigation Options*, Western Engineers, Inc. (WEI), 2006.
- [15] *The Passage of Turbid Water through Lake Mead*, N.C. Grover and C.S. Howard, ASCE, 1938.
- [16] Water Research Commission Report No. TT 91/97, *Dealing with Reservoir Sedimentation*, G.R. Basson and A. Rooseboom, 1997.
- [17] *Reservoir Sedimentation Handbook*, G.L. Morris and Fan Jiahua, McGraw-Hill, 1998.
- [18] *Design of Small Canal Structures*, Bureau of Reclamation, 1978.
- [19] *Design of Spillways and Outlet Works for Dams – A Design Manual*, Part I, “General Considerations,” Bureau of Reclamation, undated.
- [20] EM No. 14 – *Beggs Deformeter Stress Analysis of Single Barrel Conduits*, Bureau of Reclamation, 1968.
- [21] Memorandum - To: Head, Structural Behavior and Analysis Section, From: C.L. Mantei, Subject: Analysis of Additional Conduit Shapes, Bureau of Reclamation, 1971.
- [22] EM-1110-2-1602 – *Hydraulic Design of Reservoir Outlet Works*, U.S. Army Corps of Engineers, October 1980.
- [23] Chapter 4, “Tunnels, Shafts, and Caverns,” in *Design Standards No. 3: Water Conveyance Facilities, Fish Facilities, and Roads and Bridges*, Bureau of Reclamation, 2014.
- [24] ACER TM No. 9 – *Guidelines for Controlling Seepage along Conduits through Embankment Dams*, Bureau of Reclamation, 1987.
- [25] *Technical Manual: Conduits through Embankment Dams*, Federal Emergency Management Agency, September 2005.
- [26] *Open-Channel Hydraulics*, Ven Te Chow, Ph.D., McGraw-Hill Civil Engineering Series, 1959.
- [27] *Handbook of Hydraulics*, sixth edition, Ernest F. Brater and Horace William King, 1976.

**Design Standards No. 14: Appurtenant Structures for Dams
(Spillways and Outlet Works) Design Standards**

- [28] ACER TM No. 3 – *Criteria and Guidelines for Evacuating Storage Reservoirs and Sizing Low-Level Outlet Works*, Bureau of Reclamation, 1990.
- [29] *Interim Dam Safety Public Protection Guidelines*, Bureau of Reclamation, August 2011.
- [30] *Federal Guidelines for Dam Safety: Hazard Potential Classification System for Dams*, Federal Emergency Management Agency, April 2004.
- [31] EM No. 42 – *Cavitation in Chutes and Spillways*, Bureau of Reclamation, April 1990.
- [32] EM No. 41 – *Air-Water Flow in Hydraulic Structures*, Bureau of Reclamation, December 1980.
- [33] EM-1110-2-1601 – *Hydraulic Design of Flood Control Channels*, U.S. Army Corps of Engineers, June 1994.
- [34] DSO-07-07 – *Uplift and Crack Flow Resulting from High Velocity Discharge Over Offset Joints*, Bureau of Reclamation, December 2007.
- [35] EM No. 25 – *Hydraulic Design of Stilling Basins and Energy Dissipators*, Bureau of Reclamation, March 1984.
- [36] Research Report No. 24 – *Hydraulic Design of Stilling Basin for Pipe or Channel Outlets*, Bureau of Reclamation, 1978.
- [37] Technical Notes – “Computing the Trajectory of Free Jets,” by Tony L. Wahl, Kathleen H. Frizell, and Elizabeth A. Cohen, *ASCE Journal of Hydraulic Engineering*, February 2008.
- [38] *Computing Degradation and Local Scour – Technical Guideline for Bureau of Reclamation*, January 1984.
- [39] *Prediction of Scour Depth from Free Falling Flip Bucket Jets*, D. Yildiz and E. Uzupek, *International Water, Power, and Dam Construction*, November 1994.
- [40] “Free Jet Scour below Dams and Flip Buckets,” P.J. Mason and K. Arumugam, *ASCE Journal of Hydraulic Engineering*, Vol. 111, No. 2, 1985.
- [41] *Earth and Rock Surface Spillway Erosion Risk Assessment*, J.L. Wibowo, D.E. Yule, and E. Villanueva, *Proceedings, 40th U.S. Symposium on Rock Mechanics*, Anchorage, Alaska, 2005.

Chapter 4: General Outlet Works Design Considerations

- [42] “Technical Manual: Overtopping Protection for Dams,” Federal Emergency Management Agency, P-1015, May 2014.
- [43] HEC No. 11, Publication No. FHWA-IP-89-016 – *Design of Riprap Revetment*, Federal Highway Administration, March 1989.
- [44] *Engineering Geology Field Manual*, second edition, Volume 1, Bureau of Reclamation, 1998.
- [45] *Guideline for Performing Foundation Investigation for Miscellaneous Structures*, Bureau of Reclamation, December 2004.
- [46] Chapter 5, “Protective Filters,” of Design Standards No. 13 – Embankment Dams, Bureau of Reclamation, November 2012.
- [47] *Design of Spillways and Outlet Works for Dams – A Design Manual*, Part II, Volume II, Chapters 6 and 7, Bureau of Reclamation, February 1988.
- [48] *Design Standards No. 13 – Embankment Dams*, Chapter 3, “Foundation Surface Treatment,” Bureau of Reclamation, March 2013.
- [49] *Engineering Geology Field Manual*, second edition, Volume 2, Bureau of Reclamation, 2001.
- [50] *Recommendations for Prestressed Rock and Soil Anchors*, fourth edition, Post Tensioning Institute (PTI), January 2004.
- [51] REC-ERC-82-17 – *Frost Action in Soil Foundations and Control of Surface Structure Heaving*, Bureau of Reclamation, June 1982.
- [52] *Drainage for Dams and Associated Structures Manual*, Bureau of Reclamation, 2004.
- [53] ACI 350-06 – *ACI Code Requirements for Environmental Engineering Concrete Structures and Commentary*, ACI Committee 350, American Concrete Institute, 2006.
- [54] ACI 318-14 – *Building Code Requirements for Structural Concrete and Commentary*, ACI Committee 318, American Concrete Institute, September 2014.
- [55] *Design Criteria for Concrete Retaining Walls, Report of the Task Committee on Design Criteria for Retaining Walls*, Bureau of Reclamation, July 1977.
- [56] *Minimum Design Loads for Buildings and Other Structures*, ASCE Standard, ASCE/SEI 7-10, 2013.

**Design Standards No. 14: Appurtenant Structures for Dams
(Spillways and Outlet Works) Design Standards**

- [57] *Guidelines for Earthquake Design and Evaluation of Structures Appurtenant to Dams*, United States Committee On Large Dams (USCOLD), May 1995.
- [58] *Design Standards No. 9 - Buildings*, Bureau of Reclamation, 1972.
- [59] EM-1110-2-2104 – *Strength Design for Reinforced Concrete Hydraulic Structures*, U.S. Army Corps of Engineers, November 2016.
- [60] *Evaluation of Reinforcing Bars in Old Reinforced Concrete Structures*, Engineering Data Report No. 48, Concrete Reinforcing Steel Institute, 2001.
- [61] Position Paper: “Detailed Concrete Reinforcement Design Drawings,” Bureau of Reclamation, Technical Service Center, Civil Engineering Services, March 2000.
- [62] *ACI Detailing Manual-2004*, SP-66(04), ACI Committee 315, American Concrete Institute, 2004.
- [63] TM No. TSC-8100-Standards-2016-1, *Standard Drawings 40-D-60003 and 40-D-60004, Revision 0, Background and Development*, Bureau of Reclamation, Technical Service Center, September 2016.
- [64] Working Document: “Detailed Reinforcement Drawing Guidelines,” Standard STD-8130-1, Bureau of Reclamation, Technical Service Center, March 15, 2001.
- [65] *Concrete Surface Tolerances, Finishes, and Curing Reference Material*, Bureau of Reclamation, January 25, 1990.
- [66] *Guide to Concrete Repair*, Second Edition, Bureau of Reclamation, Technical Service Center, August 2015.
- [67] Working Document: “Gates and Valves,” Bureau of Reclamation, undated.
- [68] *Guidelines for Safety Evaluation of Mechanical Equipment*, Bureau of Reclamation, 1992.
- [69] *Selection of Outlet Works Gates and Valves*, W.H. Kohler, ASCE, 1969.
- [70] ACER TM No. 4 – *Criteria for Bulkheading Outlet Works Intakes for Storage Dams*, Bureau of Reclamation, 1982.

Appendix A

Examples: Outlet Works Location, Type, and Size

Example No. 1. – Dam T (New Embankment Dam): Construct New Multipurpose River Outlet Works

Example No. 2. – Dam R Modifications (Existing Concrete Dam): Construct New Multipurpose River Outlet Works

Example No. 3. – Dam Q (Existing Embankment Dam): Modify Existing River Outlet Works

Example No. 1 – Dam T (New Embankment Dam): Construct New Multipurpose River Outlet Works

Background

Based on planning studies, including exploration and materials testing, a preferred dam site has been selected on an offstream location in Montana. This dam site is in a rather wide valley with considerable alluvial overburden on the valley floor, but limited or no overburden on the valley side slopes. The topography and appraisal-level cost estimates were key factors in determining that Dam T will be an embankment (earthfill) dam. The design requirements include:

- **Total storage capacity** associated with maximum normal reservoir water surface (RWS) (top of active conservation) will be at least 121,100 acre-feet, which is associated with RWS elevation 6882. Other authorized reservoir capacity allocations (RCAs) include:
 - Active storage pool of 90,750 acre-feet between RWS elevations 6801 and 6882.
 - Inactive storage pool of 23,800 acre-feet between RWS elevations 6760 and 6801.
 - Dead storage pool of 6,500 acre-feet below RWS elevation 6760.

There will be no joint use capacity or exclusive flood storage. The reservoir will provide recreation, fishery, water quality, and municipal and industrial (M&I) water.

- **The zoned earthfill dam** has a height of at least 260 feet, a crest width of 40 feet, and a crest length of at least 1,600 feet (at the top of active conservation, elevation 6882). The final height and crest length will be based on flood surcharge and freeboard above elevation 6882. It is anticipated that the inflow design flood (IDF) will be temporarily stored and released after the event has occurred. With this in mind, the flood surcharge will be equal to the total volume of the IDF. Freeboard requirements will be established through a robustness study following procedures outlined in Chapter 2, “Hydrologic Considerations,” of this design standard.
- **The IDF** was based on the process for selecting the IDF, detailed in Chapter 2, “Hydrologic Considerations,” of this design standard. The current critical probable maximum flood (PMF) was selected as the IDF.

**Design Standards No. 14: Appurtenant Structures for Dams
(Spillways and Outlet Works) Design Standards**

To temporarily store the IDF, the flood surcharge pool would be 12,200 acre-feet between RWS elevations 6882 and 6890. Additionally, freeboard requirement of 3 feet above the maximum RWS (top of flood surcharge) was determined from a robustness study. These establish the dam crest elevation of 6893 feet. This resulted in the estimated baseline total risks being at acceptable levels, which is in an area of the f-N Chart associated with decreasing justification to take action to reduce risks. For additional discussion of the IDF selection process and of the f-N Chart, see Chapter 2 “Hydrologic Considerations,” of this design standard.

- Appurtenant structures are anticipated to include a pump-storage feature (pumping plant and conduit) that will convey water from a nearby major river to the offstream dam reservoir and a multipurpose river outlet works. The river outlet works will be required to pass diversion flows during construction, evacuate the flood surcharge after a flood event, provide low-level discharge capacity to meet emergency evacuation requirements, and meet normal reservoir operation requirements.

It should be highlighted that a spillway will not be part of the Dam T facility, due to considerations including:

- Dam T will be an offstream facility with a very small drainage basin.
- The flood surcharge space will be able to safely accommodate the IDF, which has been equated to the current critical PMF. There will also be freeboard requirements associated with the maximum RWS and the dam crest.
- The outlet works will have sufficient discharge capacity to evacuate the flood surcharge in a timely manner.
- Misoperation (without intervention) of the pump-storage facilities, in terms of inadvertently filling the reservoir to the point of overtopping the dam, is very unlikely given that the pumping capacity is small compared to the flood surcharge capacity (i.e., assuming no releases, it would take approximately 30 days to fill the reservoir space between the top of active conservation [6882 feet] and the dam crest [6893 feet]).

As noted in Chapter 3, “General Spillway Design Considerations,” of this design standard, storage and multipurpose dams without a spillway should be the exception, not the rule.

- Existing downstream conditions include an undeveloped 2-mile reach, which would convey any releases to the major river downstream. A controlling

consideration is to limit maximum releases to the safe channel capacity associated with this major river system or no more than 2,000 cubic feet per second (ft³/s).

Design Requirements

It is vital when locating, sizing, and typing an outlet works that the design requirements be clearly defined which, in the case of Dam T facilities, included:

- **Diversion during construction**, which would involve having the outlet works sufficiently constructed to pass flows prior to closing off the initial diversion system that would pass flows through an embankment dam notch (i.e., an embankment dam section not placed). Based on procedures outlined in Chapter 2, “Hydrologic Considerations,” of this design standard, it was determined that the diversion discharge capacity and cofferdam system should be able to safely accommodate at least a 25-year flood event. This flood event would require a discharge capacity of 200 ft³/s at a RWS of 6745 feet.
- **Normal release requirements** are associated with fishery and water quality needs and would require a discharge capacity range of 10 to 250 ft³/s with the reservoir in the active conservation pool, between RWS elevations 6801 and 6882.
- **Flood evacuation requirements** are associated with releasing floodwaters temporarily stored within the flood surcharge pool between RWS elevations 6882 and 6890. Discharge capacity would be in the range of 100 to 200 ft³/s, which is associated with timely drawdown of the flood surcharge space, along with minimizing the potential adverse effects on the reservoir rim (i.e., limiting the potential for landslides).
- **Reservoir evacuation requirements** are typically associated with an emergency drawdown of the reservoir from the maximum normal RWS or top of active conservation (elevation 6882). The discharge capacity will be sized to meet this dam’s classification as a low risk, high hazard facility. The discharge capacity of 1,250 ft³/s at the top of active conservation (elevation 6882) will meet these requirements.
- **M&I requirements** are associated with downstream stakeholder needs, including satisfying water rights claims and a settlement with an Indian reservation. A future pressurized water distribution system will convey releases of 100 ft³/s with the reservoir in the active conservation pool between RWS elevations 6801 and 6882.

For more information, see the data table, which is part of the “Checklist – Outlet Works Design Considerations” found in section 4.3.2 in this chapter. With the

Design Standards No. 14: Appurtenant Structures for Dams (Spillways and Outlet Works) Design Standards

design requirements defined, the outlet works location, type, and size are determined. These features are discussed in the following sections.

Hydraulic Structure Location

Based on preliminary flood routings and evacuation studies, it was determined that the reservoir evacuation requirements would set the maximum size of the outlet works. Additionally, the M&I requirements would set the minimum release requirements. This is further discussed in the next section (“Hydraulic Structure Size and Type”). These preliminary studies also confirmed a combination of the discharge capacity and the flood surcharge storage, which set the maximum RWS of 6890 feet and the dam crest of 6893 feet. The dam size and other site-specific conditions and considerations influenced the location of the outlet works. These conditions and considerations include:

- **Selection of a tunnel conveyance feature**, rather than a conduit conveyance feature, will have a notable bearing on the location of the outlet works. Considerations included:
 - The dam site is characterized by a wide valley covered with a thick layer of poorly consolidated alluvium flanked by steep abutments. The alluvium was considered unsuitable as a foundation for an outlet works conduit conveyance feature. For a rock foundation, the site-specific conditions would require a conduit to be placed along the abutments fairly high in the reservoir.
 - The embankment dam geometry makes it difficult to develop an alignment suitable for hydraulic considerations (minimum bends) that would result in an economical and accessible foundation for an outlet works conduit conveyance feature.
 - Depth of embankment above an outlet works conduit conveyance feature would be substantially greater than normally considered for the conduit shapes typically used by Reclamation for embankment dams (less than or equal to 250 feet). A special shaped conduit could be considered, but it would complicate design and construction, resulting in increased cost.
 - Both dam abutments are considered acceptable for tunnel design and construction.
 - There were no suitable reservoir rim locations that could provide economical and technically feasible sites for either a conduit or tunnel conveyance feature.

- **Selection of the left abutment over the right abutment for the tunnel conveyance feature** was based on the following considerations:
 - For the right abutment, there would be challenges associated with the upstream and downstream portal excavations and difficulties in locating suitable foundation for both the (upstream) intake structure and the (downstream) terminal structure (located adjacent to the downstream toe of the embankment dam).
 - The tunnel conveyance feature would be considerably shorter through the left abutment than through the right abutment. However, for the left abutment, there would be a very long (upstream) approach channel required for diversion during construction and some challenges in locating suitable foundation for the (upstream) intake structure and the (downstream) terminal structure (located a safe distance from the downstream toe of the embankment dam).
- **Selection of vertical and horizontal alignments** was influenced by the need to locate the outlet works on/in competent rock foundation and minimize the amount of excavation needed to locate the intake structure on competent rock foundation. Additionally, an important consideration involved minimizing the tunnel length and associated cost. Finally, at least a 40-foot buffer (distance) between the tunnel and the dam foundation contact would be required to ensure that the dam foundation contact is not damaged during the tunneling operations. This will require a bend (curve) in the horizontal alignment. These considerations led to a horizontal alignment consisting of a 370-foot length of tunnel between the upstream portal and 41-degree bend, as well as a 1,025-foot length of tunnel between the 41-degree bend and the downstream portal. Based on the previous considerations, the vertical alignment of the tunnel is anchored by the location of the upstream portal, which invert is at elevation 6727 (approximate elevation of competent rock for the intake structure foundation and sufficient competent rock for tunneling above the portal invert elevation). The downstream portal invert is at elevation 6707 (approximate elevation of competent rock for any downstream components of the outlet works and sufficient competent rock above the tunneling invert at downstream portal).

For more information, see the location table, which is part of the “Checklist – Outlet Works Design Considerations” found in section 4.3.2 in this chapter. Given the previously noted site-specific conditions and considerations, the outlet works will be located through the left abutment of the new embankment dam (see figure A-1).

**Design Standards No. 14: Appurtenant Structures for Dams
(Spillways and Outlet Works) Design Standards**

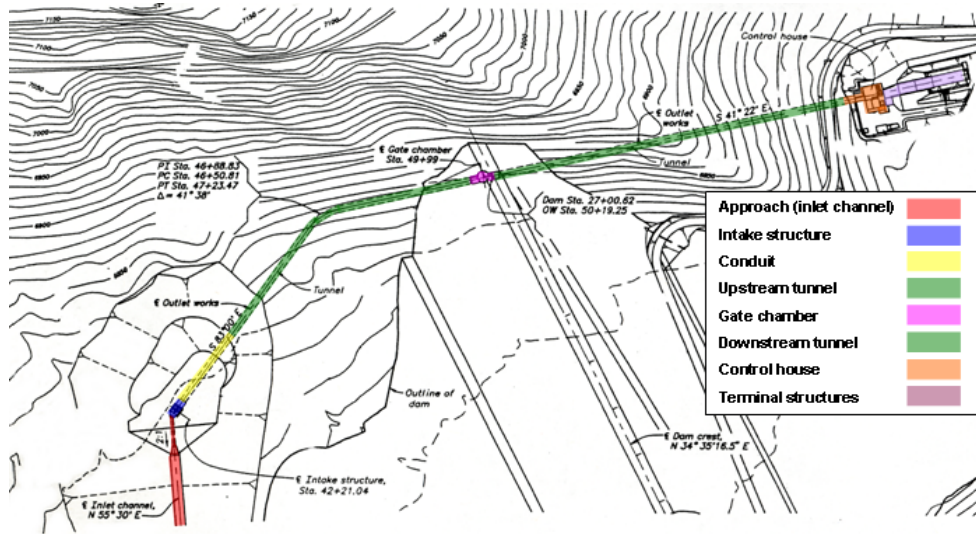

Figure A-1. Plan: horizontal alignment of outlet works.

Hydraulic Structure Type and Size

Due to the numerous design requirements, the outlet works will be a multipurpose river outlet works. To provide the flexibility to meet these design requirements, arrangement 1 hydraulic control would be employed. This arrangement would include a guard gate located near the projected dam crest centerline, a pressurized steel pipe contained in a reinforced concrete lined tunnel between the guard gate and downstream tunnel portal, and a regulating gate located in a control house immediately downstream of the downstream tunnel portal. Hydraulic sizing was based on:

- Assume maximum friction losses when sizing all components, except for the terminal structure.
- Assume minimum friction losses when sizing the terminal structure.

The configuration will consist of the following components (features):

- Approach (inlet) channel will be needed to address diversion during construction. Since significant excavation of a thick layer of alluvium will be needed to place the intake structure on a rock foundation, an excavated approach channel will be required to convey water from the reservoir to the intake structure. Also, the approach channel invert elevation, side slopes, and alignment are based on passing diversion flows (up to 200 ft³/s at no more than RWS 6745 feet, and an average maximum velocity of 5 feet per second [ft/s]) associated with the 25-year flood, along with avoiding the dam footprint and borrow areas.

Chapter 4: General Outlet Works Design Considerations

- The intake structure will be a drop inlet type that will minimize the size of both temporary and permanent excavation and allow backfilling of some of the excavation around the intake structure. This is particularly important given the potential for slope instability of the excavated alluvium, which could lead to plugging of the intake structure. Additionally, a drop inlet structure facilitates diversion requirements by providing a temporary low-level opening at the downstream limits of the approach channel. The permanent horizontal bellmouth entrance (top of dead storage, RWS elevation 6760) will be set 30 feet above the base of the intake structure, which will be 5 feet above the backfill. Also, by setting the bellmouth entrance elevation at 6760 feet, the intake structure can be located about 40 feet away from the permanent excavated alluvium slopes surrounding the structure (see figure A-2).

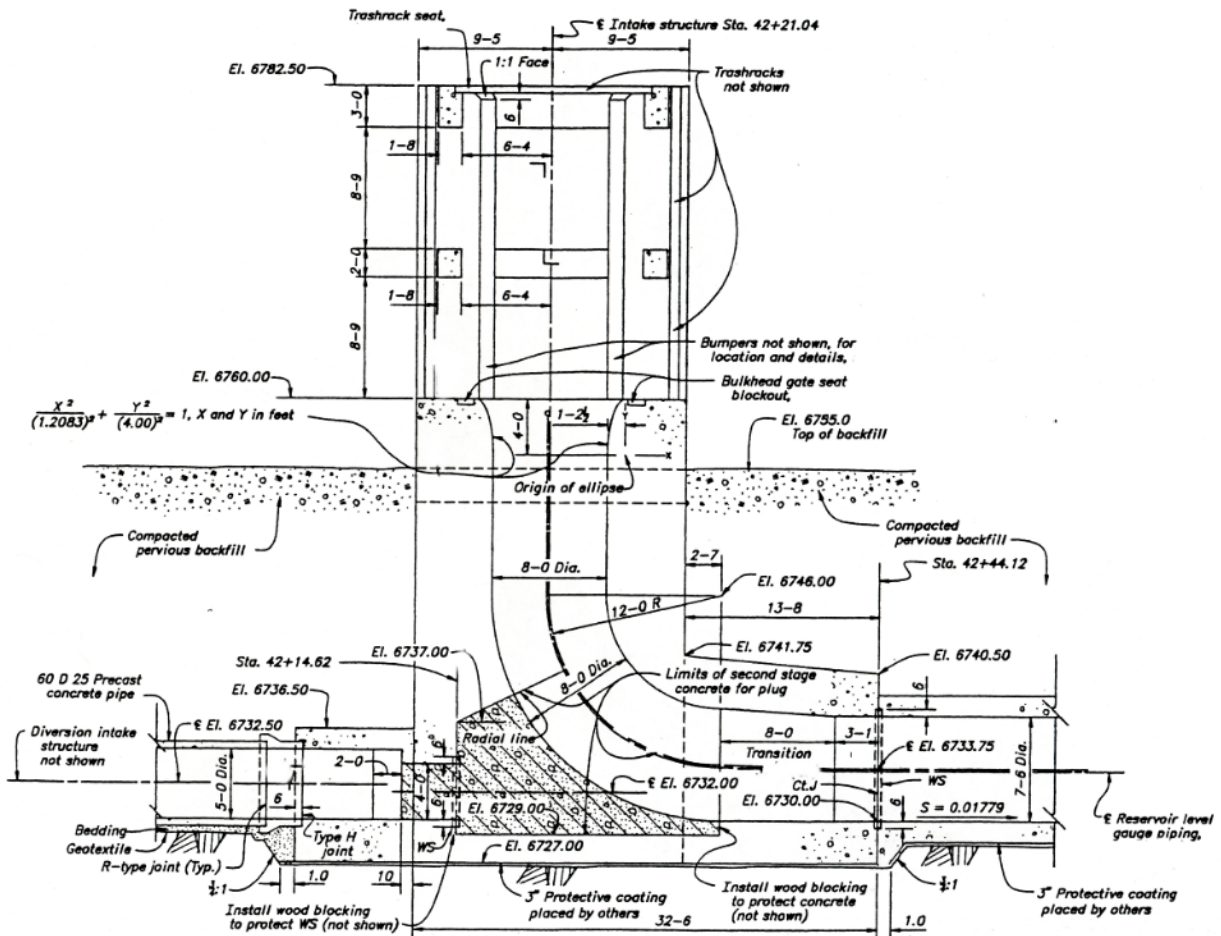

Figure A-2. Profile: drop inlet intake structure.

**Design Standards No. 14: Appurtenant Structures for Dams
(Spillways and Outlet Works) Design Standards**

The conveyance features included reinforced concrete lined tunnels and a short section of reinforced concrete conduit connecting the intake structure to the upstream tunnel portal. These conveyance features are further discussed in the following bullets:

- Because of the location of the intake structure, a short length (72.5 feet long) of a Shape B (cross section defined by circular shape inside and modified horseshoe shape outside) conduit connects the intake structure to the upstream tunnel portal. This pressure conduit will be buried (backfilled). The size (cross section) of the conduit (7-foot 6-inch inside diameter) was governed by the size of the tunnels (see figure A-3).

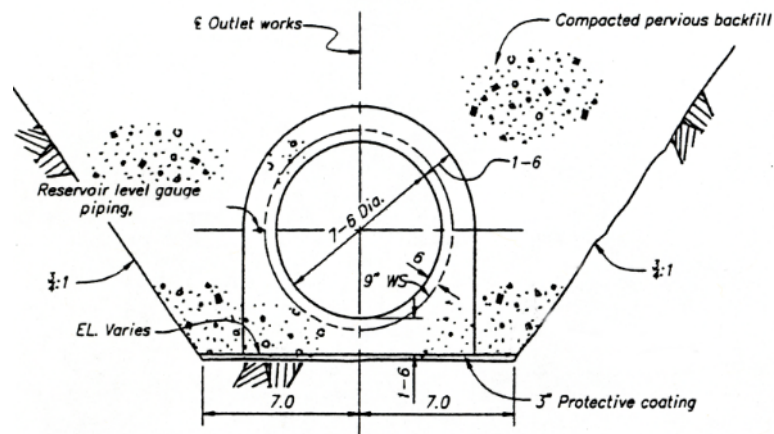

Figure A-3. Section: shape B pressurized conduit.

- Because there will be a guard gate located near the projected centerline of the dam, there will be an upstream and downstream tunnel section. Given the geology of the left abutment, it was anticipated that the tunnels would be constructed using either a roadheader or by drilling and blasting. Also, for a lined tunnel, the finished dimension should be at least 7 feet¹ (for more details, see Chapter 4, “Tunnels, Shafts, and Caverns,” of *Design Standards No. 3, Water Conveyance Facilities, Fish Facilities, and Roads and Bridges*).

¹ While Reclamation has constructed tunnels less than 7 feet in diameter or width/height, with decreasing size, underground construction operations become increasingly congested and less efficient; depending on the length of the tunnel, there would be a higher probability of increased costs and a lengthier construction period.

Chapter 4: General Outlet Works Design Considerations

- For the 658-foot-long upstream tunnel, Shape B cross section will be used and will have a slightly larger inside diameter (7 feet 6 inches) than the minimum dimension of 7 feet. The size will facilitate access to the control structure containing the guard gate during construction (see figure A-4). Also, as previously noted, there will be a horizontal bend in the upstream tunnel to maintain at least 40 feet of clear distance between the tunnel and the dam-foundation contact.

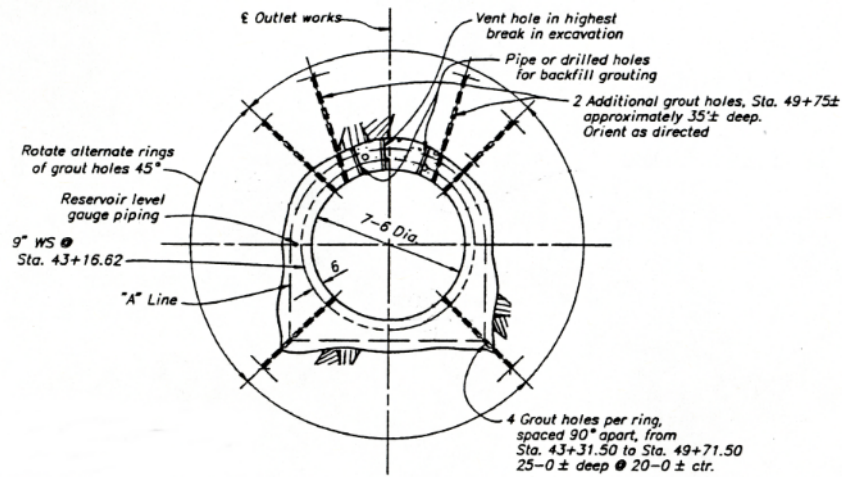

Figure A-4. Section: shape B upstream pressurized tunnel.

- For the 682-foot-long downstream tunnel, Shape F cross section (cross section defined by inside and outside horseshoe shapes) will be used and have a much larger inside dimension (11 feet). This larger tunnel will be needed to accommodate the steel pressure pipe that will convey flows between the gate chamber and downstream tunnel portal, and to provide access between the downstream tunnel portal and the gate chamber. Of note, there should be sufficient access space to remove and replace the largest component associated with the guard gate, which is the hydraulic cylinder and gate stem² (see figure A-5).

² It was determined that access through the downstream tunnel would be more economical than providing an access shaft through the left abutment of the dam connecting the projected dam crest to the gate chamber.

**Design Standards No. 14: Appurtenant Structures for Dams
(Spillways and Outlet Works) Design Standards**

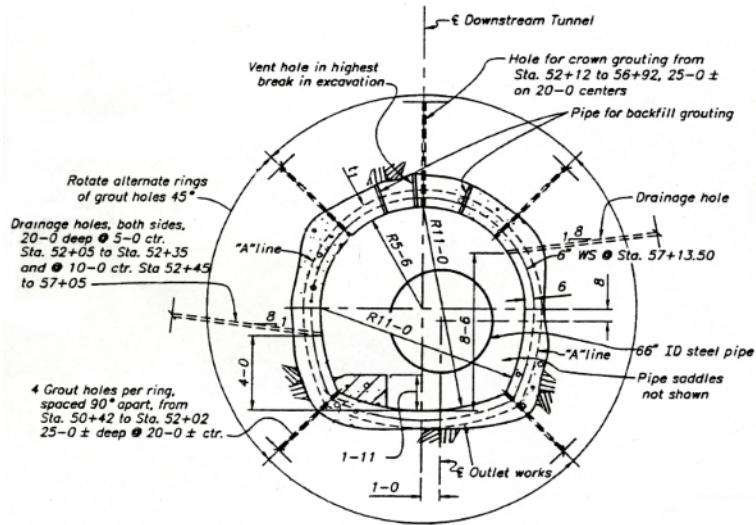

Figure A-5. Section: shape F downstream tunnel (access tunnel carries a 66-inch pressurized steel pipe).

- The control structures included a gate chamber housing the guard gate near the projected dam centerline and a control house containing the regulating gates and isolating valves downstream of the downstream tunnel portal.
 - The gate chamber must be sufficiently large to not only accommodate the guard gate, but also to provide sufficient space to service the gate, which could include removing and replacing the gate leaf and hydraulic cylinder and gate stem. The selected guard gate was a 4-foot-wide by 6-foot-high outlet gate (virtually the same as a bonneted slide gate), which can handle hydraulic heads in excess of 250 feet and accommodate the maximum design discharge of 1,250 ft³/s (see figure A-6). The guard gate will only be operated in a fully closed or open position. Finally, to ensure hydraulic control at or downstream of the guard gate (i.e., at the downstream regulating gate), the upstream conveyance feature cross-sectional area should be at least 1.1 times the wetted area of the gate. In this case, the upstream inside tunnel area is 44.2 square feet (ft²), which is greater than 1.8 times the wetted area of the guard gate (24 ft²).
 - The control house must be sufficiently large to accommodate the regulating gate and any needed operating and maintenance activities (see figure A-7). Additionally, because of the multipurpose release requirements, which can range from about 10 ft³/s to 1,250 ft³/s, a bypass system will be required. The system (trifurcation) will include:

Chapter 4: General Outlet Works Design Considerations

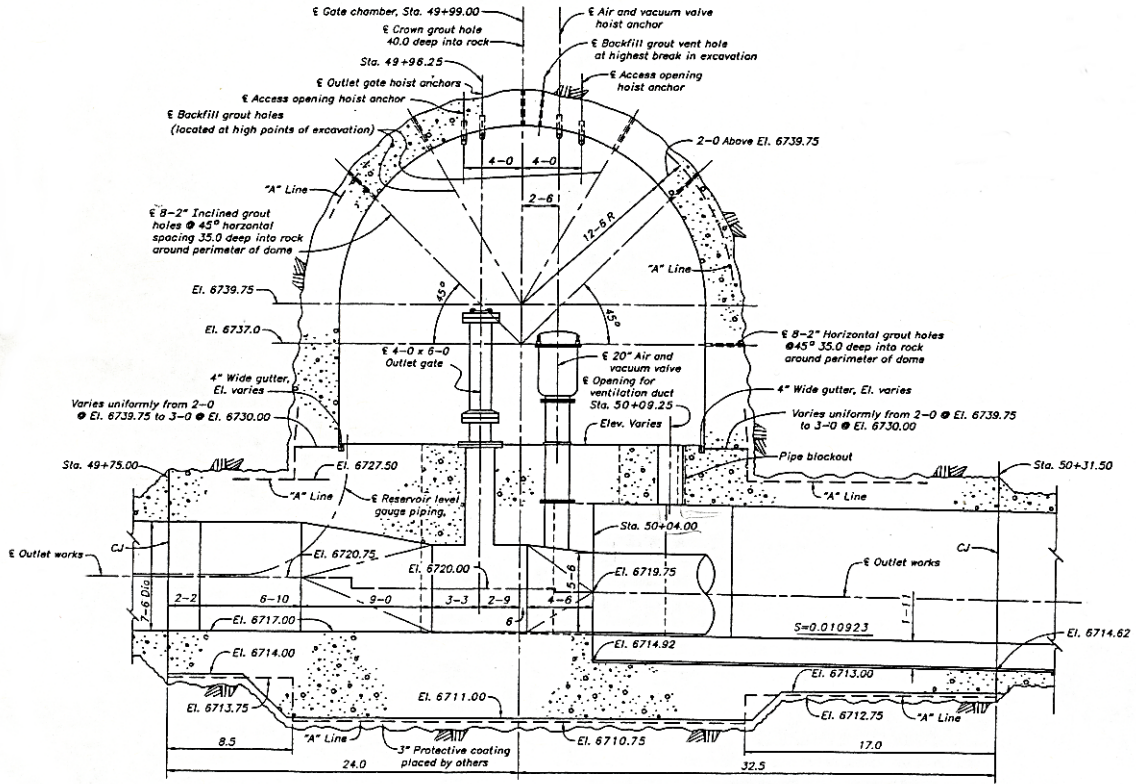

Figure A-6. Profile: gate chamber control structure.

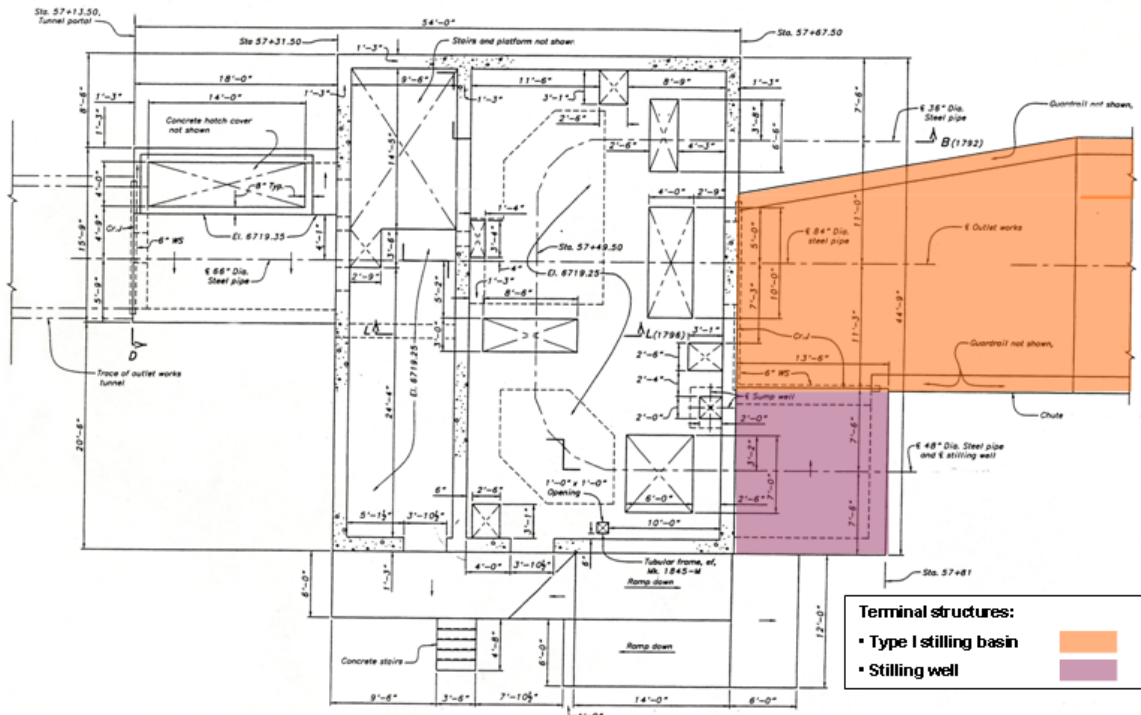

Figure A-7. Plan: control house control structure.

**Design Standards No. 14: Appurtenant Structures for Dams
(Spillways and Outlet Works) Design Standards**

- A 66-inch-diameter steel pipe regulated by a 60-inch jet-flow gate sized (diameter) to ensure hydraulic control at the gate (i.e., upstream pipe area of 23.8 ft² is greater than 1.2 times the gate area of 19.6 ft²). Also, the maximum design discharge of 1,250 ft³/s must be achieved when the RWS is at the top of active conservation (elevation 6882). Operation of this portion of the system will be limited to emergency evacuation of the reservoir.
- A 48-inch-diameter steel bypass pipe regulated by a 38-inch-diameter sleeve valve. Additionally, a 48-inch-diameter isolation butterfly valve will be installed upstream of the sleeve valve and used to close this portion of the bypass for maintenance when other parts are being operated. The 48-inch-diameter steel pipe area of 12.6 ft² is more than 3.8 times the sleeve valve wetted area (the sum of the multiple port openings is 3.3 ft²). The design discharge of 10 to 250 ft³/s can be achieved when the RWS is at or above the top of inactive storage (elevation 6801). Operation of this portion of the bypass system will address all normal releases and evacuation of the flood storage.
- A 36-inch-diameter steel pipe will provide municipal and industrial (M&I) future releases. A 36-inch isolation butterfly valve installed downstream of the trifurcation is used to close this portion of the system when needed, while the other parts are in operation. In addition to the butterfly valve, a blind flange will be installed at the end of the pipe until completion of the water distribution system in the future. The design discharge of 100 ft³/s can be achieved when the RWS is at the top of inactive storage (elevation 6801). Operation of this portion of the bypass system will address future Indian water right requirements and necessary M&I.
- Terminal structures will be needed for operating the 60-inch jet-flow gate and the 38-inch sleeve valve.
 - For the operation of the 60-inch jet-flow gate, a Type I stilling basin (horizontal apron) was selected, which will contain the hydraulic jump associated with maximum design discharge of 1,250 ft³/s before releasing flows into the exit channel (see figure A-7).

Chapter 4: General Outlet Works Design Considerations

- For the operation of the 38-inch-diameter sleeve valve, a stilling well was selected, which will dissipate the kinetic energy associated with normal releases and evacuation of the flood surcharge of up to 250 ft³/s before releasing flows into the Type I stilling basin located adjacent to the stilling well (see figure A-7).
- Exit channel will initially convey flows through culverts located at the end of the Type I stilling basin and beneath a service access road. The releases will then be further stilled by a Type VI impact terminal structure before entering a grouted riprap exit channel. Grouted riprap was selected due to the lack of larger rock (requires a median diameter, D_{50} , of 18 inches if not grouted³). The exit channel has been sized to safely accommodate up to the maximum design discharge of 1,250 ft³/s.

For more information, refer to the type and size table, which is part of the “Checklist – Outlet Works Design Considerations” in section 4.3.2 in this chapter. Given the previously noted considerations used to select components, the new outlet works will be a pressurized system employing arrangement 1 hydraulic controls, which is a preferred configuration.

Finalize Design

Once the outlet works is located, typed, and sized, the next step is to undertake the hydraulic, foundation, and structural design refinements in a risk framework. For more information, refer to the analysis and design table, which is part of the “Checklist – Outlet Works Design Considerations” in section 4.3.2 in this chapter.

The downstream control house provides access to the tunnel and gate chamber and contains the controls for the gates and valves. The house is designed to keep the tunnel access separate from the control room. In case of a failure in the downstream conduit, resulting in flooding of the tunnel access to the gate chamber, access to the control room would allow the emergency gate in the gate chamber to be closed.

³ D_{50} is the designation for the median size rock of a well-graded riprap.

Example No. 2 – Dam R Modifications (Existing Concrete Dam): Construct New Multipurpose River Outlet Works

Background

Dam R is located approximately 25 miles upstream from the nearest town in New Mexico. The dam was completed in 1911 and provides a total storage capacity of 1,381,600 acre-feet at the design maximum normal RWS (top of active conservation) of 2136 feet. The reservoir provides flood control, recreation, irrigation water, hydroelectric power, and M&I water. Other authorized reservoir capacity allocations include:

- Flood surcharge pool of 178,300 acre-feet between RWS elevations 2136 and 2146.
- Active storage pool of 1,364,200 acre-feet between RWS elevations 1989 and 2136.
- Inactive storage pool is not provided.
- Dead storage pool of 17,400 acre-feet below RWS elevation 1989.
- Streambed elevation is 1902 feet and was used to define the hydraulic height (difference between the top of active conservation [2136 feet] and streambed [1902 feet] = 234 feet).

The existing major features are summarized below:

- **The cyclopean masonry¹ thick-arch dam** has a structural height of 280 feet, crest width of 16 feet, crest length of 723 feet, and crest elevation of 2142. Also, a 4-foot-high parapet wall is located on the upstream dam face, which effectively increased the top of flood surcharge to elevation 2146.
- **Reinforced concrete spillways** located on each abutment are controlled by a total of nineteen 20- by 15.9-foot radial gates. The combined discharge capacity is 150,000 ft³/s at RWS elevation 2146.

¹ Cyclopean masonry is mass concrete that includes very large rocks (sometimes referred to as “plum stones”) within the interior of a concrete placement (away from the surface). The concept of using plum stones was to reduce the cement and sand matrix associated with the mass concrete placements. Reclamation’s inventory of cyclopean masonry dams includes Elephant Butte, Pathfinder, and the original Theodore Roosevelt Dams.

**Design Standards No. 14: Appurtenant Structures for Dams
(Spillways and Outlet Works) Design Standards**

- **The river outlet works** is located on the right side of the dam and extends through the dam to a control structure on the canyon wall. The outlet works consists of two steel pipes each controlled by 54-inch butterfly valves and a third steel pipe controlled by a 66-inch ring-jet valve. Total discharge capacity is 3,160 ft³/s at the top of active conservation (elevation 2136).
- **A powerplant** is located on the left canyon wall immediately downstream of the dam. Two 10-foot-diameter steel pipe penstocks convey water through the dam to the powerplant. Approximately 1,000 ft³/s can be released through the powerplant.

It was determined that total baseline risk, primarily due to flood-induced overtopping of the dam, was unacceptably high, and there is increasing justification to reduce total risk. Flood routings identified that frequency flood return periods greater than 50,000 years (about 60 percent of the current critical PMF) would overtop the dam which, in turn, could lead to severe erosion of both abutments and instability of portions of the dam, resulting in uncontrolled release of the reservoir.

Using the process for selecting the (IDF, detailed in Chapter 2, “Hydrologic Considerations,” of this design standard, a frequency flood equal to a return period of 150,000 years was selected as the IDF. This frequency flood is similar in size to the current critical PMF, so the IDF was equated to the PMF, which will reduce total risks to acceptable levels.

With the selection of the IDF, modifications to the dam, along with replacement of the spillways and outlet works, are needed to achieve sufficient risk reduction. Because the focus of this example is on the outlet works, only brief descriptions of the dam and spillway modifications are provided in the following bullets. Discussion of the outlet works replacement is detailed after these bullets.

- **RCA changes** were needed to increase the active pool, create an exclusive flood control pool, and increase the flood surcharge. These changes will define the reservoir operations so that a significant portion of the IDF volume can be temporarily stored while limiting flood releases to no more than the safe downstream channel capacity of 150,000 ft³/s. The revised RCA elevations and storage include:
 - Flood surcharge pool of 1,245,300 acre-feet between RWS elevations 2175 and 2218.
 - Exclusive flood control pool of 557,000 acre-feet between RWS elevations 2151 and 2175.
 - Active storage pool of 1,591,800 acre-feet between RWS elevations 1989 and 2151.

Chapter 4: General Outlet Works Design Considerations

- Hydraulic height will increase from 234 feet to 249 feet because the top of active conservation will increase from RWS elevation 2136 to 2151.
- **The dam** will be raised 77 feet to accommodate the additional storage associated with the changed RCA. This raise will be accomplished with a conventional mass concrete downstream overlay extending from the base of the dam to a crest elevation of 2218 feet.
- **Spillway replacements** will be needed because the dam raise will require removal of the existing spillways, which are located on both abutments adjacent to the existing dam. Additionally, to maintain the same discharge capacity of the existing spillways, the replacement spillways are changed to orifice types, specifically top-seal radial gate spillways located through the raised dam abutment thrust blocks. This type of gate will allow the spillways to be located near the existing spillway locations and take advantage of the increased hydraulic head.

Design Requirements

It is vital when locating, sizing, and typing an outlet works to clearly define the design requirements which, in the case of Dam R facilities, included:

- **Diversion during construction** is needed for up to a 4-year period and is complicated because of the many overlapping activities that will be underway upstream of, on, and downstream of the dam. Cofferdams isolating the existing spillways from the reservoir and the tailrace area immediately downstream of the dam will be needed before some of these activities are initiated. Because of these activities, operation of the existing outlet works and penstocks will be severely limited (i.e., will impact/impede construction activities if operated). Also, the discharge capacities of the existing outlet works and penstocks are relatively small, which, if used, may require a significant temporary reservoir drawdown during construction activities to safely accommodate flood events. Based on procedures outlined in Chapter 2, “Hydrologic Considerations,” of this design standard, it was determined that the diversion discharge capacity should be able to safely accommodate at least a 25-year flood event. This flood event would require a discharge capacity of 5,400 ft³/s at a RWS of 2136 feet. Also, a modest temporary reservoir drawdown (restriction) to elevation 2115 will be imposed during the construction period.
- **Normal release requirements** are associated with maintaining minimum river release requirements of 2,400 ft³/s between RWS elevations 1989 and 2151.

Design Standards No. 14: Appurtenant Structures for Dams (Spillways and Outlet Works) Design Standards

- **Power release requirement** will involve a power penstock that conveys up to 1,200 ft³/s from the left side of the dam axis to the existing powerplant.
- **Reservoir evacuation requirements** are typically associated with an emergency drawdown of the reservoir from the maximum normal RWS or top of active conservation (elevation 2151). The combined discharge capacities of the spillway and outlet works replacements will be sized to meet evacuation requirements associated with a dam classification of a low risk, high hazard. For the outlet works, discharge capacity of 12,000 ft³/s at the top of active conservation (elevation 2151) will meet this requirement.
- **Flood routing requirements** include the use of the river outlet works to augment spillway releases when passing more frequent smaller flood events. Due to a very large discharge capacity needed for emergency evacuation, the outlet works will be used to help pass flood events.

For more information, refer to the data table, which is part of the “Checklist – Outlet Works Design Considerations” in section 4.3.2 in this chapter. With the design requirements defined, the outlet works location, type, and size are determined. These features are discussed in the following sections.

Hydraulic Structure Location

Based on preliminary flood routings and evacuation studies, it was determined that the reservoir evacuation requirements would establish the maximum size of the outlet works. Additionally, the stream release requirements would establish the minimum release requirements. This is further discussed in the next section (“Hydraulic Structure Size and Type”). These preliminary studies also established a combination of the discharge capacity (spillways and outlet works) and the flood surcharge storage, which established the maximum RWS of 2218 feet and the dam crest of 2218 feet. It should be noted that a 3.5-foot-high parapet wall (elevation 2221.5) located on the upstream limits of the dam crest will provide freeboard and was estimated using procedures found in Chapter 2, “Hydrologic Considerations,” of this design standard. The dam size and other site-specific conditions influenced the location of the outlet works. These conditions and considerations include:

- **Selection of a new tunnel conveyance feature**, rather than modifying the existing conduit conveyance features (outlet works and power penstocks located through the existing dam), will have a notable bearing on the location of the outlet works. Considerations included:
 - Due to the construction activities over a 4-year period upstream of, on, and downstream of the dam, operation of the existing outlet

Chapter 4: General Outlet Works Design Considerations

works and power penstocks will be limited. Also, extending these structures downstream of the construction area would be very difficult as it would interfere with construction activities.

- The combined discharge capacities of the existing outlet works and power penstocks are not sufficient to pass the 25-year diversion flood without a significant reservoir drawdown.
- **Selecting the left abutment** over the right abutment for the new tunnel conveyance feature was based on the following considerations:
 - The overriding consideration will be maintaining the existing powerplant (located on the downstream left canyon wall). For this reason, there are significant efficiencies (including cost) associated with a combined river and power outlet works.
 - The right abutment geology is suitable for a tunnel, but it will be somewhat more complicated due to the jointing and the presence of several shear zones.
- **Selection of vertical and horizontal alignment** will be influenced by the revised RCA elevations and storage, the need to locate the outlet works on/in competent rock foundation, dealing with underwater construction (placement) of the intake structure (lake tap), and combining river and power outlet works. Additionally, an important consideration involved minimizing the tunnel length and associated cost. Finally, at least a 50-foot buffer (distance) between the tunnel and the existing dam-foundation contact will be required to ensure that the dam-foundation contact is not damaged during the tunneling operations. To maintain a buffer between the tunnel and dam-foundation contact, a bend (curve) in the horizontal alignment will be required. These considerations led to a horizontal alignment consisting of:
 - A 440-foot length of tunnel between the upstream portal and 101-degree bend
 - A 250-foot length of tunnel between the 101-degree bend and the bifurcation (wye) for the river outlet works and power penstock tunnels
 - A 225-foot length of river outlet works tunnel between the bifurcation and the downstream portal
 - A 355-foot length of power penstock tunnel between the bifurcation and the existing powerplant

Design Standards No. 14: Appurtenant Structures for Dams (Spillways and Outlet Works) Design Standards

Based on the previous considerations, the vertical alignment of the tunnel is anchored by the top of dead storage (RWS elevation 1989), which will set the intake structure sill elevation. The downstream portal inverts are elevation 1928 for the river outlet works and 1903 for the power penstock (approximate elevation of competent rock for any downstream components of the outlet works and sufficient competent rock for tunneling above the portal invert elevation). Additionally, the invert elevations are above the maximum tailwater elevation.

For more information, refer to the location table, which is part of the “Checklist – Outlet Works Design Considerations” in section 4.3.2 in this chapter. Given the previously noted site-specific conditions, a new combined river and power outlet works will be located through the left abutment of the modified concrete dam (see figure A-8).



Figure A-8. Plan: horizontal alignment of outlet works.

Hydraulic Structure Type and Size

Due to the numerous design requirements, the outlet works will be a multipurpose river outlet works. For the river outlet works portion, discharge flexibility to meet these design requirements is important. Therefore, arrangement 5 hydraulic controls will be employed. This arrangement will include an emergency gate located near the projected dam axis (upstream of the river outlet works and power penstock bifurcation) and a pressurized, reinforced concrete lined tunnel with a steel liner (between the gate chamber and downstream tunnel portal). Also, to increase the range of discharge and accommodate available gates sizes, the steel pipes encased in reinforced concrete downstream of the tunnel portal include two bifurcations in series (i.e., separating the single steel pipe into two steel pipes, then into four steel pipes, all encased in reinforced concrete). A guard gate and regulating gate for each of the four steel pipes are located in a control house downstream of the tunnel portal. Hydraulic sizing was based on:

- Assume maximum friction losses when sizing all components, except for the terminal structure.
- Assume minimum friction losses when sizing the terminal structure.

The configuration will consist of the following components (features):

- Approach (inlet) channel will not be needed because the intake structure will be located on an excavated rock bend along the canyon wall within the reservoir.
- The intake structure will be a drop inlet type, which will be installed underwater using lake tap methodology. This methodology is summarized by the following generalized steps (see figure A-9).
 - Excavate a rock bench underwater at floor elevation 1986 feet (excavation of upstream tunnel is suspended once excavation is about 125 feet downstream of the location of the intake structure until the intake structure has been fully installed).
 - Drill a 20-foot-diameter vertical shaft in rock underwater from a barge.
 - Install prefabricated, 16-foot-diameter, vertical steel shaft liner (including bellmouth entrance vertical bend or elbow, and downstream dished head bulkhead).
 - Place tremie concrete and grout in annulus between the 20-foot-diameter drilled shaft and 16-foot-diameter steel liner.

**Design Standards No. 14: Appurtenant Structures for Dams
(Spillways and Outlet Works) Design Standards**

- Install prefabricated trashrack structure and upstream bulkhead on intake structure sill.
- Complete approximately 125 feet of excavation from upstream tunnel to the intake structure and remove downstream bulkhead.
- Using a filling line, slowly water up the intake structure and the upstream tunnel between the upstream bulkhead located on the intake structure and the emergency gate located in the gate chamber control structure. Remove the upstream bulkhead using divers and barge.

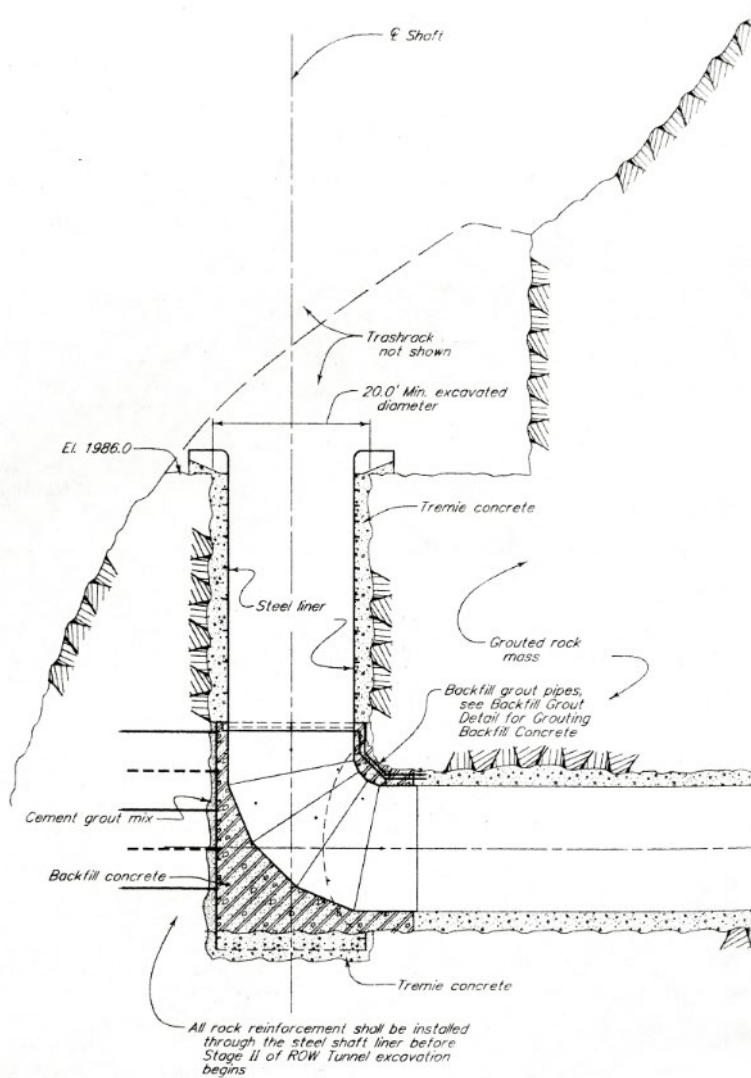

Figure A-9. Profile: lake tap drop inlet intake structure.

Chapter 4: General Outlet Works Design Considerations

- The conveyance features included reinforced concrete lined tunnels with (downstream tunnel) and without a (upstream tunnel) steel liner, and a short section of steel pipes encased in reinforced concrete, which connects the downstream river outlet works portal to the control structure. These conveyance features are further discussed in the bulleted items that follow:
 - Because an emergency gate will be located near the projected dam axis, there will be an upstream and downstream tunnel section. Given the geology of the left abutment (very hard, high strength rock), it was anticipated that the tunnels would be constructed using drill and blast methods (for more details, see Chapter 4, “Tunnels, Shafts, and Caverns,” of *Design Standards No. 3 - Water Conveyance Facilities, Fish Facilities, and Roads and Bridges*).
 - For the 580-foot-long upstream tunnel (between the downstream end of the intake structure vertical bend and the upstream end of the control structure, housing the guard gate), a circular inside and horseshoe outside cross section will be used and will have a significantly larger inside diameter (16 feet) than the minimum dimension of 7 feet. The size is necessary to pass flows up to about 12,000 ft³/s and minimize hydraulic head losses when operating the powerplant (see figure A-10). Also, as previously noted, there will be a horizontal bend in the upstream tunnel to maintain at least 50 feet of clear distance between the tunnel and the dam-foundation contact.

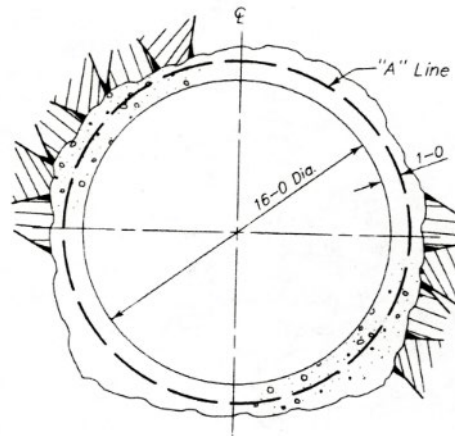

Figure A-10. Section: circular inside shape and horseshoe outside shape for upstream and downstream tunnels.

- For the 50-foot-long bifurcation (downstream of the gate chamber control structure), a circular steel liner inside and horseshoe outside cross section will be used and will have the same large inside diameter (16 feet) as the upstream tunnel. The power penstock

**Design Standards No. 14: Appurtenant Structures for Dams
(Spillways and Outlet Works) Design Standards**

portion of the bifurcation will have a smaller inside diameter (12 feet 6 inches) and will be steel lined to reduce hydraulic head losses.

- For the 185-foot-long downstream tunnel for the outlet works, a circular inside and horseshoe outside cross section will be used and will have the same large inside diameter (16 feet) as the upstream tunnel. Note: this portion of the river outlet works tunnel will continue to be lined with reinforced concrete and also include a steel liner to address reduced rock cover and add some structural redundancy associated with containing high-pressure, high-volume flows downstream of the dam.
- The 110-foot steel pipe section downstream of the portal is encased in reinforced concrete, and there are two bifurcations in series (i.e., the one 16-foot-diameter steel pipe will be separated into four 7-foot 6-inch-diameter steel pipes).
- **The control structures** include a gate chamber housing the emergency gate for the combined outlet works (both river and power outlet works) near the projected dam axis and a control house containing the guard gates and regulating gates for the river outlet works downstream of the downstream tunnel portal.
 - The gate chamber must be sufficiently large to not only accommodate the emergency gate, but also to provide adequate space to service the gate, which could include removing and replacing the gate. Also, a 320-foot-high, 16-foot inside diameter access shaft is provided. Additionally, a control house at the top of the shaft will be used to operate the emergency gate. The selected emergency gate is a 13-foot-wide by 16-foot-high, wheel-mounted (fixed-wheel) gate, which can handle the maximum hydraulic head of 282 feet (head associated with the maximum design RWS) and accommodate the maximum design discharge of 12,000 ft³/s (see figure A-11). Finally, it should be noted that hydraulic control at the gate may not occur because the gate wetted area (208 ft²) is slightly larger than the wetted area of the upstream tunnel (201 ft²). However, for the planned operation of the outlet works, maintaining hydraulic control at the emergency gate is not considered critical because the gate will only be used in the fully opened or closed position, and it will only be used to shut down the entire outlet works during an emergency (during unbalanced or flowing conditions) or for maintenance and inspection (during balanced or not flowing conditions).

Chapter 4: General Outlet Works Design Considerations

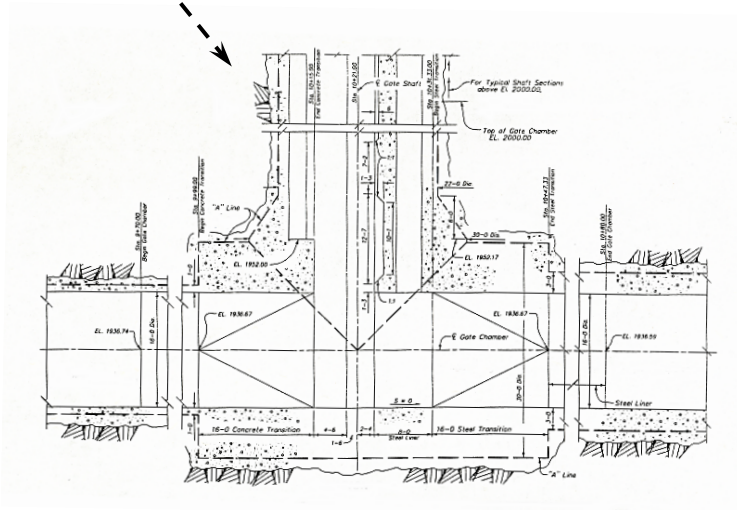
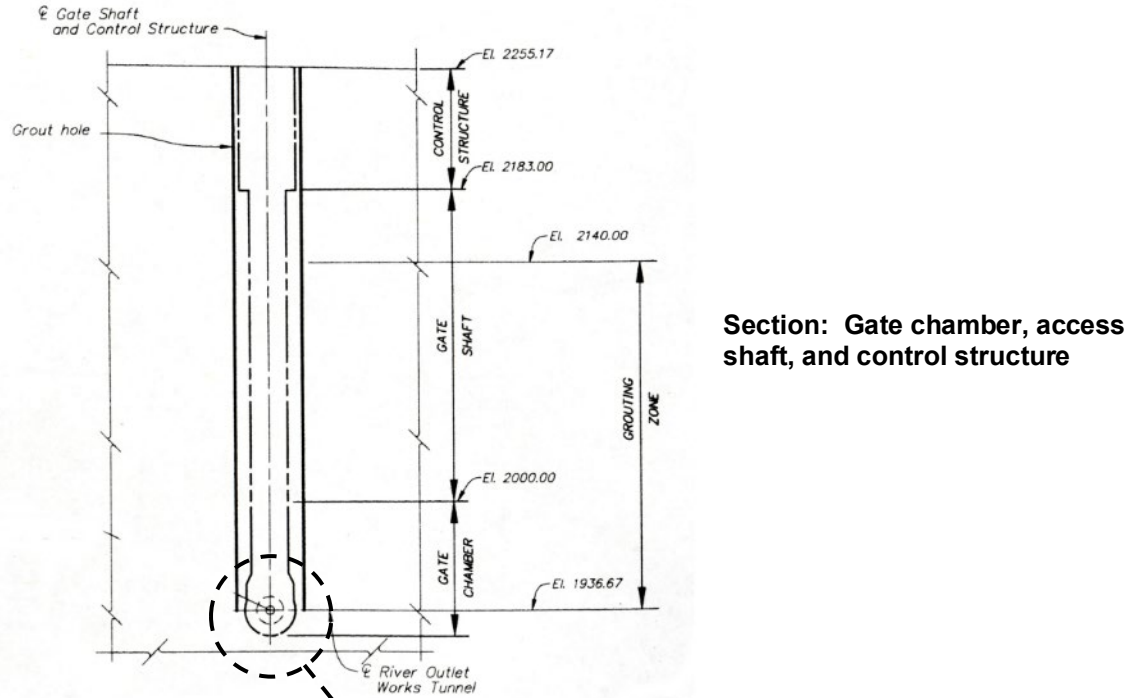

Figure A-11. Profile: gate chamber control structure.

Design Standards No. 14: Appurtenant Structures for Dams (Spillways and Outlet Works) Design Standards

- Another control house, located near the downstream river outlet works tunnel portal, must be sufficiently large to accommodate the four guard gates (90-inch-diameter ring-follower gates) and four regulating gates (90-inch-diameter jet-flow gates). These gates can handle the maximum hydraulic head of 282 feet for the ring-follower gate and the jet-flow gate (see figure A-12). It should be highlighted that the wetted areas of both gates are the same as the wetted area of the upstream pipe. Typically, the upstream conveyance feature wetted area should be at least 1.1 times the gate wetted area. In this case, designs for and fabrication of 90-inch ring-follower and jet-flow gates were already completed for another project. Therefore, because these sized gates can release more than the maximum design discharge when fully opened, hydraulic control at the gates will be maintained by not fully opening the gates for most operations (exception will be made under emergency conditions when it is critical to lower the reservoir as quickly as possible).
- **A terminal structure** will be needed for operation of the four 90-inch jet-flow gates. Dissipation of kinetic energy (associated with discharge) will be accomplished by establishing sufficient tailwater depths in an excavated rock channel between the regulating gates and the river. The bottom of the excavation will be unlined, but reinforced concrete retaining walls will establish the channel sides. This component is similar to a Type I terminal structure (see figure A-13)
- **An exit channel** will be incorporated into the terminal structure.
- For more information, refer to the type and size table, which is part of the “Checklist – Outlet Works Design Considerations” in section 4.3.2 in this chapter. Given the previously noted considerations used to select components, the new outlet works will be a pressurized system employing arrangement 5 hydraulic controls, which is an acceptable configuration.

Finalize Design

Once the outlet works is located, typed, and sized, the next step is undertaking hydraulic, foundation, and structural design refinements in a risk framework. For more information, refer to the analysis and design table, which is part of the “Checklist – Outlet Works Design Considerations” in section 4.3.2 in this chapter.

Chapter 4: General Outlet Works Design Considerations

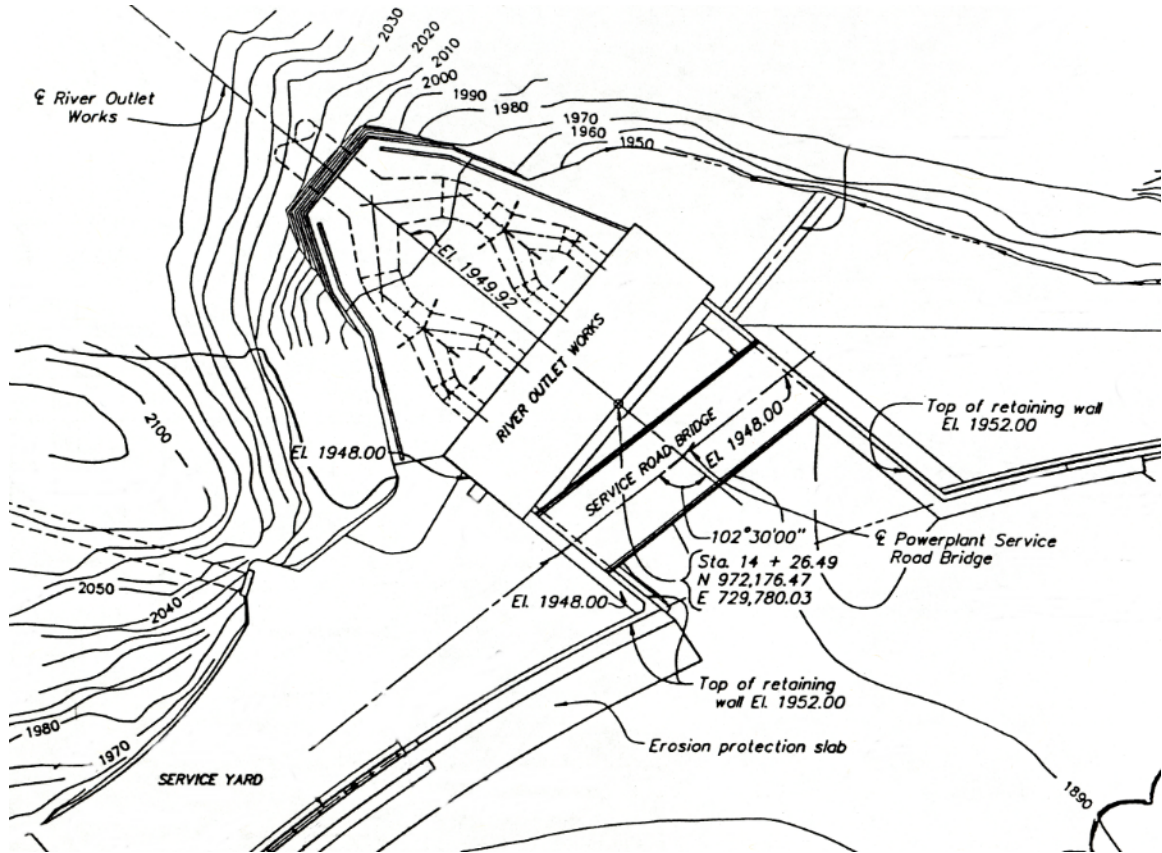

Figure A-12. Plan: control house control structure and downstream terminal structure.

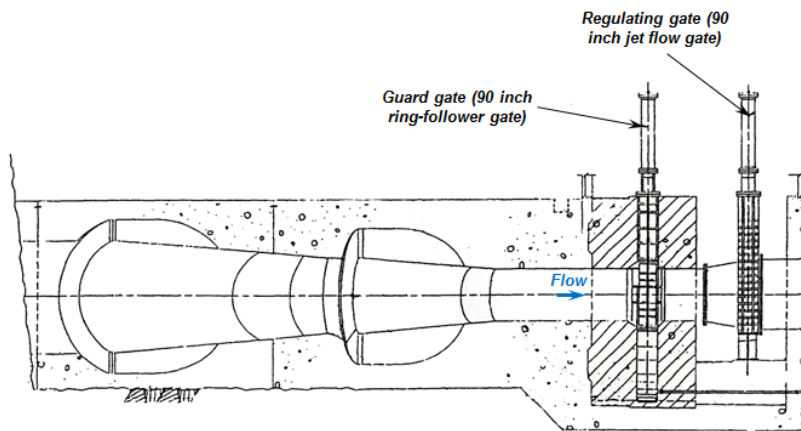

Figure A-13. Section through control house along river outlet works centerline.

Example No. 3 – Dam Q (Existing Embankment Dam): Modify Existing River Outlet Works

Background

Dam Q is located approximately 16 miles upstream from the nearest town in Idaho. The dam was completed in 1910 and provides a total storage capacity of 36,900 acre-feet at the design maximum normal RWS (top of active conservation) of 4242.7 feet. The reservoir provides recreation and irrigation water. Other authorized reservoir capacity allocations include:

- Flood surcharge pool of 11,500 acre-feet between RWS elevations 4242.7 and 4255.
- Active storage pool of 35,100 acre-feet between RWS elevations 4188.5 and 4242.7.
- Inactive storage pool of 300 acre-feet between RWS elevations 4185.8 and 4188.5.
- Dead storage pool of 1,500 acre-feet below RWS elevation 4185.8.
- Streambed elevation is 4181 feet at the dam centerline and is used to define the hydraulic height (difference between the top of active conservation [4242.7 feet] and streambed [4181 feet] = 61.7 feet).

The existing major features are summarized below:

- **The embankment dam** has a structural height of 76 feet, crest width of 20 feet, crest length of 2,550 feet, and a crest elevation of 4255 feet. Of note, a 3.5-foot-high parapet wall is located on the upstream dam face, which effectively increased the top of flood surcharge to elevation 4258.5. Also, the dam was constructed by the semi-hydraulic fill method.¹ Primarily because of the method of constructing the dam, significant seepage issues have been observed and monitored since the reservoir was filled.

¹ Material hauled to the site by rail was dumped from both upstream and downstream sides of the embankment, and the finer material washed to the lower and center part of the dam.

**Design Standards No. 14: Appurtenant Structures for Dams
(Spillways and Outlet Works) Design Standards**

- **The reinforced concrete spillway** was replaced in 1990. It is located on the left abutment and consists of an uncontrolled, 75-foot-wide, reinforced concrete ogee crest control structure; a 75-foot-wide, 65-foot-long reinforced concrete chute; and a grouted riprap exit channel. The discharge capacity is 7,600 ft³/s at RWS elevation 4255.
- **The river outlet works** is located on the right side of the dam and extends through the dam. The outlet works consists of a box intake structure with trashracks, a 66-inch-diameter, steel-lined, reinforced concrete upstream conduit; a reinforced concrete gate chamber; and an access shaft, which is positioned upstream of the dam crest and can be accessed by way of a foot bridge from the dam crest. The gate chamber houses 66-inch gate valves in tandem (upstream guard gate valve and downstream regulating gate valve). A 66-inch-diameter, redwood-lined, reinforced concrete conduit extends downstream from the gate chamber to a riprap-lined exit channel. The discharge capacity is restricted to 600 ft³/s during normal operations and 700 ft³/s during emergency operations (such as emergency evacuation of the reservoir). This restriction is imposed to ensure freeflow conditions in the downstream conduit and to minimize displacement of riprap in the exit channel. Also, it should be noted that the downstream conduit has settled (sagged) more than 1 foot, which resulted in significant cracking of portions of the conduit. Finally, seepage has been observed coming through these cracks and through the embankment surrounding the downstream end of the conduit.

It has been determined that total baseline risks (primarily due to internal erosion through the dam, through cracks in the downstream outlet works conduit, and along the outlet works) were unacceptably high, and there was increasing justification to reduce total risk. As a result of normal operations (static conditions) and/or during flood events (hydrologic conditions), internal erosion or piping of embankment materials could lead to a dam breach and uncontrolled release of the reservoir.

To mitigate the significant risks associated with internal erosion, an evaluation process of nonstructural and structural alternatives was undertaken. It was determined that a structural alternative will be pursued to reduce total risks. The structural alternative involves modifications including:

- **The dam** will be modified by placing a zoned filter on the downstream slope, which will surround the outlet works exit area.
- **The outlet works** will be modified by installing a steel liner in the downstream outlet work conduit by constructing a terminal structure at the end of the downstream conduit and by lining the exit channel with grouted riprap

Design Requirements

It is vital when locating, sizing, and typing an outlet works to clearly define the design requirements. In the case of Dam Q, locating, sizing, and typing the modified outlet works will be straightforward given that the location is already defined and the typing is unchanged from the existing outlet works. The sizing must prevent the original discharge capacity from significant reduction, which will be facilitated by removing the existing redwood liner and replacing it with a steel liner (i.e., the finished inside diameter remains the same as the existing inside diameter: 66 inches). Other data considerations include:

- **Diversion during construction** will be a staged, 2-year effort that will initially involve draining the reservoir immediately after irrigation season (mid-September) and mobilizing and modifying the outlet works during the late fall, winter, and early spring (October through mid-March). The dam modification will not begin until the outlet works is operational, and it is anticipated to extend from early spring until late fall (March through October). Based on procedures outlined in Chapter 2, “Hydrologic Considerations,” of this design standard, acceptable levels of construction risks could be achieved if at least a 500-year flood event could be safely accommodated. To accommodate this flood event, the combined discharge of the modified outlet works and the existing spillway would be 2,200 ft³/s (1,500 ft³/s from spillway and 700 ft³/s from outlet works) at a RWS of 4249 feet. Based on flood routing studies, a temporary reservoir restriction of elevation 4230 or lower will be maintained during the construction period for the dam modification, which will allow safe passage of the 500-year flood event.
- **Normal release requirements** are associated with maintaining irrigation releases of up to 600 ft³/s between RWS elevations 4188.5 and 4242.7.
- **Flood routing requirements** include the use of the river outlet works to augment spillway releases when passing a flood event. The outlet works discharge capacity could be as much as 700 ft³/s at the top of flood surcharge (elevation 4255).
- **Reservoir evacuation requirements** are typically associated with an emergency drawdown of the reservoir from the maximum normal RWS or top of active conservation (elevation 4242.7). The discharge capacity of the modified outlet works will be unchanged from the existing discharge capacity. However, evacuation requirements will not be met for this dam, which, after modification, will be classified as a low risk, high hazard facility. For the modified outlet works, the maximum discharge capacity will be 700 ft³/s at the top of active conservation (elevation 4242.7). It should be noted that increasing the discharge capacity to meet the evacuation requirements could not be justified based on risk reduction and

Design Standards No. 14: Appurtenant Structures for Dams (Spillways and Outlet Works) Design Standards

cost; therefore, Reclamation’s management agreed upon a variance. This variance provided opportunities to meet emergency evacuation requirements if future activities (modifications) can help meet requirements at modest costs.

For more information, refer to the data table, which is part of the “Checklist – Outlet Works Design Considerations” in section 4.3.2 in this chapter. With the design requirements defined, the outlet works location, type, and size are determined, which are discussed in the following sections

Hydraulic Structure Location

As previously noted, the location (near the right abutment and through the existing dam) is already defined because the existing outlet works will be modified (see figure A-14). For more information, refer to the location table, which is part of the “Checklist – Outlet Works Design Considerations” in section 4.3.2 in this chapter.

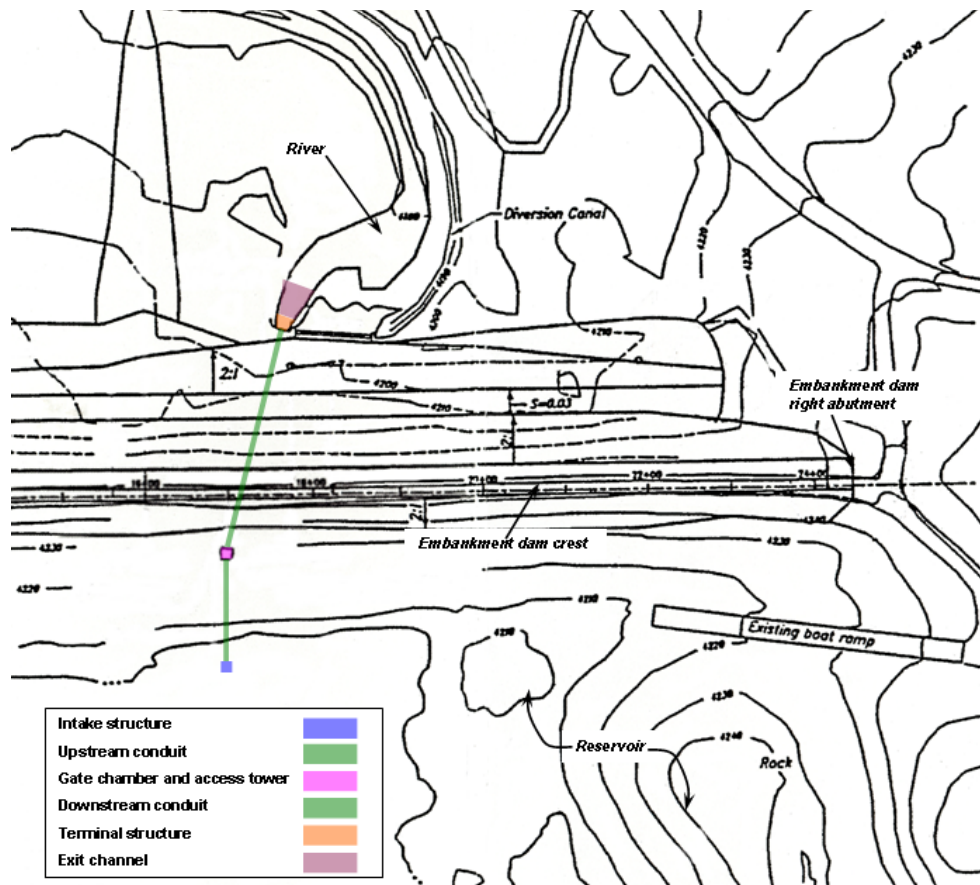
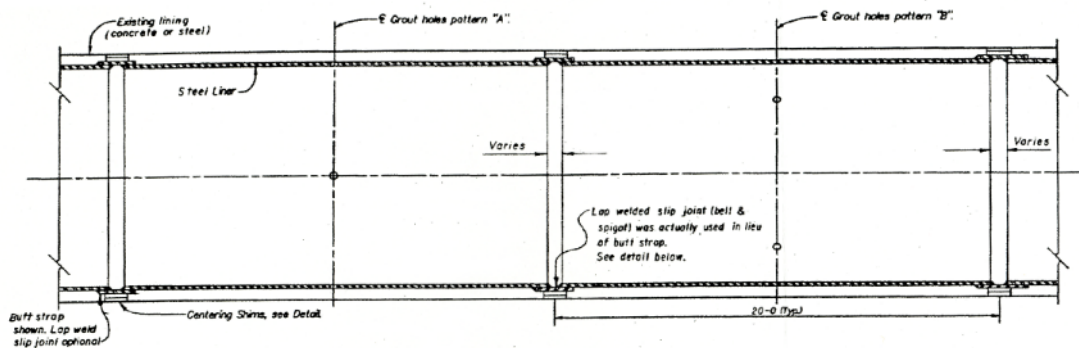

Figure A-14. Plan: horizontal alignment of outlet works.

Hydraulic Structure Type and Size

As previously noted, the type is unchanged from the existing outlet works. The sizing must prevent the original discharge capacity from significant reduction, which will be facilitated by removing the existing redwood liner in the downstream conduit and replacing it with a steel liner (i.e., the finished inside diameter remains the same as the existing insides diameter: 66 inches). Specific modifications (see figures A-15 and A-16) include:

- **The downstream conduit modification** will include a steel liner installed in 20-foot sections, pulled into place, and the ends will be butt-strapped and welded. The void (annulus) between the steel liner and existing reinforced concrete conduit will be grouted through plugs in the steel liner. Also, a zoned filter placed along the downstream slope of the existing dam will be wrapped around the downstream end of the outlet works.
- **The terminal structure** will include a new 21-foot-long, reinforced concrete stilling basin that flares from 6 feet wide at the upstream end to 12 feet wide at the downstream end. The terminal structure will be sized to contain a hydraulic jump associated with 700 ft³/s.
- **The exit channel** will include a 75-foot-long, grouted riprap trapezoidal channel that will convey flow to the river channel.



TYPICAL LONGITUDINAL SECTION THROUGH STEEL LINER

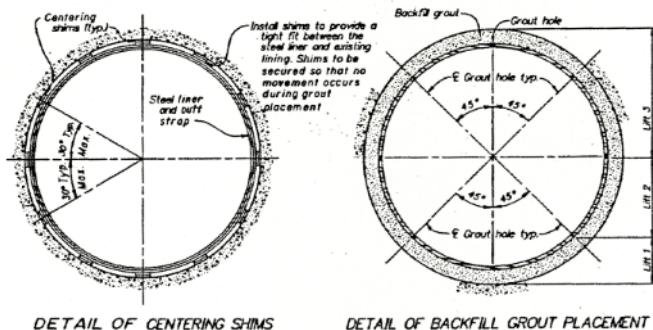

Figure A-15. Sections: steel liner installation in downstream existing conduit.

**Design Standards No. 14: Appurtenant Structures for Dams
(Spillways and Outlet Works) Design Standards**

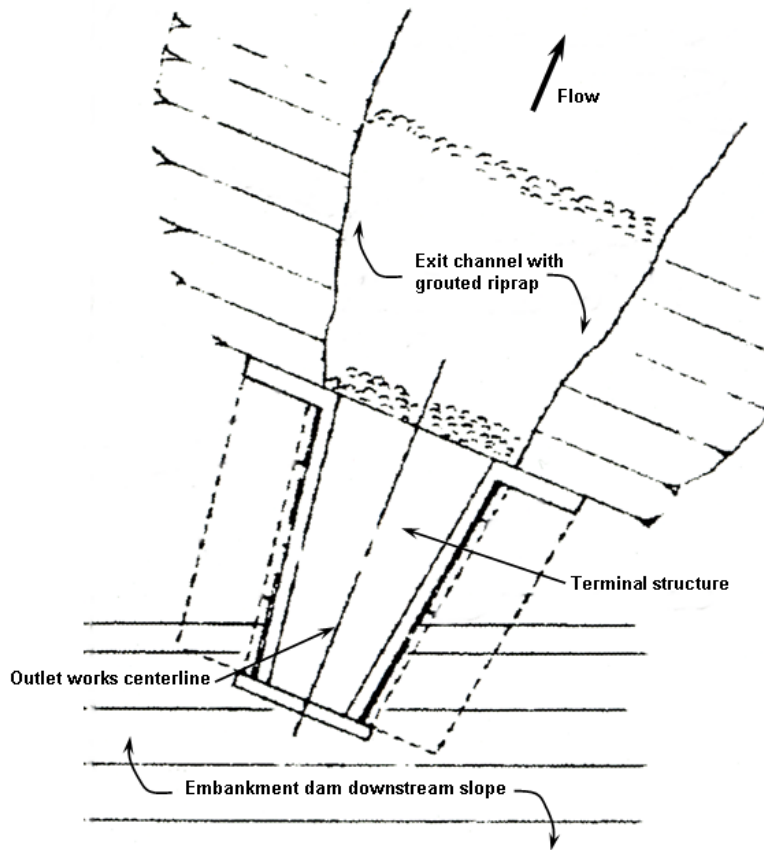

Figure A-16. Plan: terminal structure and exit channel.

Given the previously noted considerations, the modified outlet works will remain a pressurized system upstream of the gate chamber and free-flow system downstream of the gate chamber (employing arrangement 2 hydraulic controls, which is an acceptable configuration). For more information, refer to the type and size table, which is part of the “Checklist – Outlet Works Design Considerations” in section 4.3.2 in this chapter.

Finalize Design

Once the outlet works is located, typed, and sized, the next step is to undertake hydraulic, foundation, and structural design refinements in a risk framework. For more information, refer to the analysis and design table, which is part of the “Checklist – Outlet Works Design Considerations” found in section 4.3.2 in this chapter.

Appendix B

Potential Failure Modes (PFMs) for Outlet Works

Potential Failure Modes (PFMs) for Outlet Works

Quantitative risk analysis methodology will be part of evaluating, analyzing, and designing existing outlet works modifications and new outlet works associated with storage and multipurpose dams, which are typically classified as significant- and high-hazard structures. To facilitate the effort of identifying and evaluating PFMs, a list of typical PFMs associated with outlet works and grouped by loading conditions (Static, Hydrologic, and Seismic) is summarized in the following text.

Static (Normal Operations) PFMs

These static PFMs are not applicable when the outlet works is being operated to pass flood events and/or the reservoir water surface (RWS) exceeds the maximum normal RWS (either top of active conservation or top of joint use, whichever is higher). These PFMs are applicable when the outlet works is being operated to pass normal releases for such operations as irrigation, power generation, and municipal and industrial (M&I) and environmental considerations.

- **Internal erosion.** – The reservoir is at or below the maximum normal RWS. Internal erosion is the key (most important) PFM associated with outlet works through or adjacent to embankment dams. It can initiate from different mechanisms that are further discussed in the following bullets.

- **Internal erosion along or into outlet works.** – Seepage flows could increase over time through flaws or discontinuities in the fill material adjacent to the outlet works conveyance features (typically conduits), or through cracks and joint openings in the nonpressurized portion of outlet works, in the foundation, or a combination. Seepage velocities could be sufficient to carry fill material, enlarging the discontinuities until a continuous conduit/pipe develops. Internal erosion would continue, eventually leading to a



Internal erosion induced dam failure resulting from corrugated metal pipe that rusted through and exposed adjacent embankment to erosive flows (unknown dam).

**Design Standards No. 14: Appurtenant Structures for Dams
(Spillways and Outlet Works) Design Standards**

collapse of the conduit/pipe and erosion of the fill material adjacent to the outlet works and/or foundation, which would end with uncontrolled release of the reservoir. Alternatively, a sinkhole could develop above the discontinuity, resulting in instability of the embankment crest and leading to an uncontrolled release of the reservoir. Examples include the 1996 sinkhole development in the embankment overlying the existing outlet works at Reclamation's Willow Creek Dam, Montana, and the 2003 piping of material along the outlet works at Reclamation's Virginia Smith Dam, Nebraska.

- **Internal erosion due to leakage from pressurized outlet works.**

– Seepage flows could increase over time through cracks or open joints in the pressurized outlet works conveyance feature (pipe or conduit) into the fill material and/or foundation adjacent to the outlet works. Seepage velocities could be sufficient to carry fill material, enlarging the discontinuities until a continuous conduit/pipe develops. Internal erosion would continue, eroding the fill material adjacent to the outlet works and/or foundation, which would end with uncontrolled release of the reservoir. Alternatively, a sinkhole could develop above the discontinuity, resulting in instability of the embankment crest, leading to an uncontrolled release of the reservoir. An example includes the 1982 Lawn Lake Dam failure resulting from pressurized flow exiting the outlet works pipe upstream of a regulating valve into surrounding embankment material.



1982 internal erosion induced dam failure resulting from pressurized flow exiting the outlet works into the surrounding embankment material (Lawn Lake Dam, Colorado).

- **Gate and/or valve failure.**– During normal operations or periodic testing of the gates or valves, a mechanical failure occurs, resulting in displacement of the gate or valve, or a partial closure of the gate or valve. If a gate or valve displaces, an uncontrolled release of the reservoir may result. If a mechanical failure results in a partial closure of a gate or valve, loss of operational control may occur. If the gate or valve is designed to only operate in a fully open or fully closed condition, the partial closure may

Chapter 4: General Outlet Works Design Considerations

result in adverse hydraulics that could lead to a failure of the gate itself or of the downstream conduit or pipe. If there are no upstream emergency or guard gates or valves, loss of operational control of releases and loss of the reservoir may result. It should be noted that the level of release may not exceed safe downstream channel capacity and cause downstream consequences. Based on case histories, gate or valve failures are due to mechanical failures (such as the 1997 partial lowering of the sluice ring-follower gate leaf at Reclamation's Flaming Gorge Dam that resulted in the cavitation-induced failure of a portion of the outlet pipe) or misoperation failures (such as the 1985 needle valve failure at Reclamation's Bartlett Dam that resulted in catastrophic failure of the valve, significantly damaging the control house and causing a fatality).

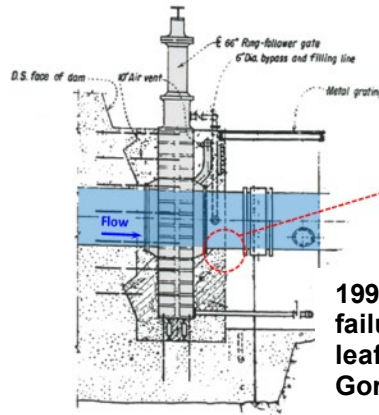

1997 cavitation-induced pipe failure due to ring-follower gate leaf drifting into flow (Flaming Gorge Dam).

- **Reinforced concrete structural failure.** – Reinforced concrete features (walls, slabs, conduits, tunnels, etc.) fail as a result of normal loading in combination with one or more deterioration mechanisms acting on the reinforced concrete and/or foundation over time. The root causes tend to be the loss of the material and strength properties of the reinforced concrete and/or foundation, along with removal of concrete and/or foundation. Of note, there is no one generic failure or incident event tree associated with reinforced concrete deterioration. Rather, the effects are typically reflected in the likelihood of events occurring for other potential failure or incident modes, such as the likelihood (probability) of open joints, offsets, surface irregularities, cracks, or spalls. Types of deterioration mechanisms that could exacerbate reinforced concrete structural failure include:

**Design Standards No. 14: Appurtenant Structures for Dams
(Spillways and Outlet Works) Design Standards**

- **Freeze-thaw deterioration and/or frost heave deterioration.** – Of greatest concern is the accumulation of water in soils adjacent to outlet works features (such as intake towers, walls, or floor slabs), which then freeze and result in large stresses on the features (referred to as frost heave).



Outlet works intake tower deterioration due to freeze-thaw cycles and ice action (unknown dam).

- **Alkali-silica-reaction (ASR) deterioration.** – As a result of alkalis in the cement and mineral constituents of some aggregates (opal and some volcanic rocks), a chemical reaction can occur, resulting in large-scale, excessive internal and overall expansion (cracking of the cement paste and aggregate).
- **Sulfate deterioration.** – As a result of some salts (sodium, magnesium, and calcium) primarily found in soils and ground water in the Western United States, a chemical reaction can occur with the cement paste (hydrated lime and hydrated calcium aluminate), which leads to considerable expansion and disruption (cracking) of the cement paste.
- **Acid deterioration.** – Primarily due to mining operations, very high acid concentrated releases can enter a reservoir and significantly lower the pH of the water. The water can react with a concrete structure and result in “softening” (dissolving) the concrete paste (sand and cement). Examples are the softening and loss of the concrete paste on submerged components and flow surfaces of the outlet works at Reclamation’s Spring Creek Debris Dam and the flow surfaces of the outlet works at Reclamation’s Soldier Creek Dam. The submerged surfaces and flow surfaces reacted with the water, which had a very low pH due to mine effluent that accumulated in the reservoir. These conditions continue to be monitored.

Chapter 4: General Outlet Works Design Considerations

- **Corrosion (chloride) deterioration.** – As a result of exposing reinforcement to the atmosphere, corrosion can take place that will eventually result in loss of strength properties and potential compromise of the reinforcement. Exposure of the reinforcement can result from other deterioration mechanisms such as freeze thaw, ASR, sulfate attack, and thermoexpansion/contraction.
- **Thermoexpansion/contraction.** – Due to radiant heat, concrete surfaces expand and may result in very large compressive stresses that tend to focus at or near contraction and/or control joints. These compressive stresses can result in cracking or spalling near the joints.

- **Loss of foundation (differential settlement).** – Foundation loss can be due to internal erosion and/or settlement that results in diminished support of the outlet works, which could lead to structural failure (collapse) of the outlet works features. An example is the 1987 unexpected significant settlement of Ridgway Dam foundation. This settlement caused



Outlet works intake tower tilting due to inadequate foundation support (unknown dam).

- excessive movement (settlement) and damage to the river outlet works conveyance features (conduits). To mitigate seepage potential along and through the conveyance features, a major grouting program was undertaken, along with concrete repairs to the damaged conduits.
- **Loss of operation.** – The following consideration of an inoperable outlet works does not directly define PFMs, but it could contribute to and/or exacerbate other PFMs where drawing down the reservoir in a timely fashion (intervention) would be an important factor in evaluating PFM risks. Considerations might include: inoperable gates or valves, inability to access and operate the outlet works in a timely fashion, slope failure, and excessive sediment buildup that buries and/or fills in the intake structure and upstream conduit, pipe, or tunnel.

**Design Standards No. 14: Appurtenant Structures for Dams
(Spillways and Outlet Works) Design Standards**

Hydrologic (flood-induced) PFMs

These hydrologic PFMs are applicable when the outlet works is being operated to pass flood events and/or the RWS exceeds the maximum normal RWS (either top of active conservation or top of joint use, whichever is higher).

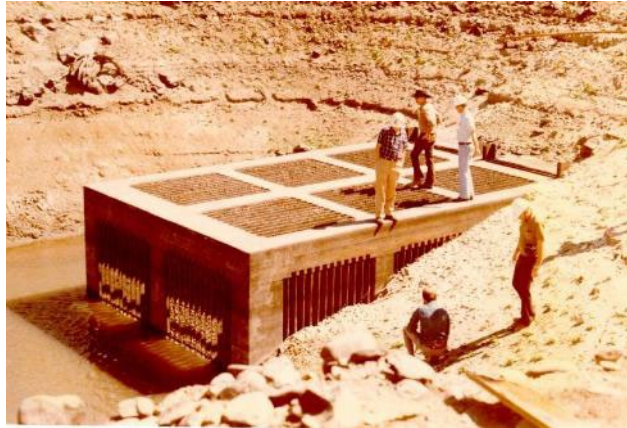

Upstream embankment dam slope has sloughed into outlet works intake structure partially clogging it, which reduced the discharge capacity (Agency Valley Dam, Oregon).

- **Dam overtopping.** – This particular PFM is typically not associated with outlet works. However, in a case where there is no spillway associated with the dam and/or one of the primary purposes of the outlet works is to pass flood events, consideration should be given to the dam overtopping PFM as it relates to the outlet works. Overtopping of a dam, dike, and/or low area (saddle) on the reservoir rim occurs when a flood event overwhelms flood surcharge storage and discharge capacity of the appurtenant structures (such as an outlet works). For an embankment dam, dike, or saddle on the reservoir rim, if the depth and duration of overtopping is sufficient, erosion will result, which could lead to breach and uncontrolled release of the reservoir. For a concrete dam, if the depth and duration of the overtopping is sufficient to erode abutments and/or foundation, leading to the undermining and destabilizing of the dam, breaching of the dam could occur, leading to uncontrolled release of the reservoir. An additional consideration for dam and dike overtopping is the potential concentration of flow along the groins (abutment contacts between the dam/dike and the foundation).
- **Elevated RWS (nonovertopping of dam) resulting in internal erosion.** – Flood-induced internal erosion of fill material along the outlet works features, in the foundation, or a combination, which would result from the RWS being substantially elevated above normal operations and/or what may have historically been experienced (i.e., first filling conditions exist). The elevated RWS would typically be above the maximum normal RWS (either top of active conservation or top of joint use storage, whichever is higher). Once the reservoir is above the maximum normal RWS, seepage flows could increase through flaws or discontinuities in the fill material adjacent to the outlet works, in the foundation, or a combination. Seepage velocities could be sufficient to carry soil material, enlarging the

discontinuities until a continuous conduit/pipe develops. Internal erosion would continue, eventually leading to a collapse of the conduit/pipe and erosion of the fill material adjacent to the outlet works and/or foundation, which would end with uncontrolled release of the reservoir.

- **Chute wall overtopping.** – This particular PFM is not typically associated with outlet works. However, consideration should be given to it if the outlet works includes a chute which is usually limited between the downstream end/portal of the conduit/tunnel and the terminal structure (such as a stilling basin). Also, unless the outlet works is used to help pass flood events where discharge exceeds the maximum design discharge, this PFM will not typically be associated with an outlet works. If the outlet works is used to pass flood events, large releases may result in overtopping of chute walls, leading to erosion of adjacent fill material, followed by undermining and failing of a portion of the chute. With extended operation, additional erosion could lead to headcutting and undermining of the conveyance features (conduits) and surrounding fill if associated with an embankment dam/dike, which could lead to an uncontrolled release of the reservoir.
- **Conduit/tunnel pressurization.** – Flood-induced discharge that exceeds the maximum design discharge, which may result in pressurizing a conduit/tunnel that was designed for free-flow conditions. This pressurization could lead to two potential failure paths: (1) the conduit/tunnel lining is overloaded and collapses, and (2) high-pressure flow is injected through conduit/tunnel joints and/or cracks into the surrounding foundation material. With extended operation, erosion adjacent to the conduit/tunnel could lead to destabilizing a portion of the conduit/tunnel lining. Once the conduit/tunnel lining has failed, extensive internal erosion (if foundation consists of erodible materials) extending to the upstream reservoir could result, as well as an uncontrolled release of the reservoir.
- **Cavitation of chute and/or conduit/tunnel/pipes.** – Discharge through a concrete-lined chute and/or a concrete-lined conduit/tunnel with flow surface offsets at joints and/or other surface irregularities, such as cracks, may create separation of high-velocity flow at the flow surface, which results in low-pressure zones (vapor bubbles and/or voids form). Also, low-pressure zones can and have been associated with areas of a conduit, tunnel, or pipe immediately downstream of a gate or valve, where there is insufficient air supply and/or the gate/valve is being misoperated (such as making releases through a very small gate or valve opening). These bubbles and/or voids rapidly collapse as they move into higher pressure zones, which issues high-pressure shock waves. Swarms of collapsing bubbles and/or voids can lead to fatigue and erosion of the flow surface

**Design Standards No. 14: Appurtenant Structures for Dams
(Spillways and Outlet Works) Design Standards**

material (such as concrete or steel liner). Cavitation damage is cumulative and may not be significant upon first operation, but damage progression increases with operation time. With extended operation, erosion of the concrete and foundation could lead to erosional headcutting upstream to the reservoir and an uncontrolled release of the reservoir. Examples include the 1997 normal operations induced cavitation of the outlet works pipe at Reclamation's Flaming Gorge Dam and the 1997 flood-induced cavitation of the outlet works conduit at Reclamation's Folsom Dam. Both examples involve cavitation damage immediately downstream of gates. Although there was significant damage, there was no breach and uncontrolled release of the reservoir.



Cavitation damage downstream of regulating gates (Palisades Dam, Wyoming).

- **Stagnation pressure of chute and/or conduit/tunnel.** – Discharge through a concrete-lined chute or conduit/tunnel leads to introduction of high-velocity, high-pressure flow through open flow surface joints or cracks, which can result in structural damage or failure of the concrete lining due to uplift pressures and/or erosion of the foundation. Displacement of portions of the concrete-lined chute or conduit/tunnel can expose the foundation to further erosion. With extended operation, erosion of the foundation could lead to additional erosional headcutting (and undermining of the structure) upstream to the reservoir and an uncontrolled release. Stagnation pressure damage may occur during a single operation, or may be cumulative, as is the case with foundation erosion.
- **Sweepout of hydraulic-jump stilling basin.** – Discharge exceeds original design levels, and sweepout of the stilling basin occurs (i.e., the hydraulic jump moves out of and downstream of the stilling basin). Erosion and headcutting initiate in the foundation downstream of the stilling basin and progress upstream, undermining and causing failure of the stilling basin. If flow durations are long enough, erosional headcutting progresses upstream, undermining and failing other outlet works features, such as the conveyance features, which could lead to uncontrolled release of part or all of the reservoir.

- **Reinforced concrete structural failure.** – Reinforced concrete features (walls, slabs, conduits, tunnels, etc.) fail as a result of hydrologic loading that exceeds the design loads. Also, if there is concrete deterioration that has weakened and/or damaged the concrete and/or foundation, the reinforced concrete structure could fail due to hydrologic loadings that are less than the original design loadings. The deteriorated concrete could exacerbate other hydrologic PFMs such as dam overtopping (due to gate or valve binding), elevated RWS leading to internal erosion (due to frost heave of outlet works walls, which opens up a seepage path between the walls and adjacent fill material), and cavitation and stagnation pressure (due to deteriorated flow surfaces). As previously mentioned, there is no single generic failure or incident event tree associated with reinforced concrete deterioration; rather, the effects are typically reflected in the likelihood of events occurring for other PFMs or incident modes, such as the likelihood (probability) of open joints, offsets, surface irregularities, cracks, and spalls. Types of deterioration mechanisms that have been experienced are further discussed in the “Static (normal operations) PFMs,” specifically “Reinforced concrete structural failure.”

Seismic (earthquake-induced) PFMs

These seismic PFMs are not applicable when the outlet works is being operated to pass flood events and/or the RWS exceeds the maximum normal RWS (either top of active conservation or top of joint use, whichever is higher in elevation). These PFMs are applicable when the outlet works is being operated to pass normal releases for such operations as irrigation, power generation, and M&I and environmental considerations.

- **Internal erosion.** – Earthquake-induced internal erosion of fill material along the outlet works features, in the foundation, or combination, which would result from the RWS at or below the maximum normal RWS (either top of active conservation or top of joint use storage, whichever is higher). Similar to the static PMFs, seismic-induced internal erosion can be initiated from different mechanisms and are further discussed in the subsequent bulleted items.
 - **Internal erosion along or into outlet works.** – As a result of seismic-induced intake structure, wall, and/or conduit deflection or collapse, as well as separation from the surrounding fill material or cracking of the foundation, seepage flows could increase through the separation adjacent to the outlet works or through foundation cracks, or a combination. Seepage velocities could be sufficient to carry fill material, enlarging the discontinuities until a continuous conduit/pipe develops. Internal erosion would continue, eventually leading to a collapse of the conduit/pipe and erosion of the fill material adjacent to the outlet works and/or foundation, which would result in

Design Standards No. 14: Appurtenant Structures for Dams (Spillways and Outlet Works) Design Standards

uncontrolled release of the reservoir. Alternatively, a sinkhole could develop above the discontinuity, resulting in instability of the embankment crest, which would result in an uncontrolled release of the reservoir.

- **Internal erosion due to leakage from pressurized outlet works.** – As a result of seismic-induced cracking or rupturing of a pressurized conduit, seepage flows could increase over time through cracks, ruptured conduit, or open joints in the outlet works conveyance feature into the fill material and/or foundation adjacent to the outlet works. Seepage velocities could be sufficient to carry fill material, enlarging the discontinuities until a continuous conduit/pipe develops. Internal erosion would continue, eroding the fill material adjacent to the outlet works and/or foundation, which would result in uncontrolled release of the reservoir. Alternatively, a sinkhole could develop above the discontinuity, resulting in instability of the embankment crest, which would result in an uncontrolled release of the reservoir.
- **Gate and/or valve failure.** – During an earthquake, a mechanical failure occurs, resulting in displacement of the gate or valve, or a partial closure of the gate or valve. If a gate or valve displaces, an uncontrolled release of the reservoir may result. If a mechanical failure results in a partial closure of a gate or valve, loss of operational control may occur. If the gate or valve is designed to only operate in a fully open or fully closed condition, the partial closure may result in adverse hydraulics that could lead to a failure of the gate itself or of the downstream conduit or pipe. If there are no upstream emergency or guard gates or valves, loss of operational control of releases and loss of the reservoir may result. It should be noted that the level of release may not exceed safe downstream channel capacity and cause downstream consequences. The seismic loadings could exacerbate existing mechanical and/or structural issues that would not lead to failure under normal loading conditions. Also, the seismic loadings could overstress and fail the outlet works gates, valves, and/or associated features, such as radial gate trunnions, even if no mechanical and/or structural issues exist.
- **Intake tower failure due to loss of foundation (differential settlement) and/or structural failure.** – As a result of a seismic event, an outlet works intake tower overturns due to foundation loss or structurally fails (collapse). Depending on the gate or valve arrangement, this could lead to uncontrolled release of the reservoir through the conduit and/or tunnel, which may or may not result in downstream consequences (i.e., depending on the level of flow; flooding which could damage property or threaten life may or may not result). An example was the 1987 unexpected significant settlement of Ridgway Dam foundation. A variation of this PFM is that a large intake tower overturns and/or collapses into a concrete dam (more likely for a thin

arch and/or multiple arch dam) located immediately downstream. The impact of the tower is sufficient to fail an upper portion of the dam, which would result in an uncontrolled release of part of the reservoir.

- **Reinforced concrete structural failure.** – Reinforced concrete features (walls, piers, slabs, conduits, tunnels, etc.) fail as a result of seismic loading, which exceeds the design loads. Also, if there is concrete deterioration that has weakened and/or damaged the concrete and/or foundation, the reinforced concrete structure could fail due to seismic loadings that are less than the original design loadings. The deteriorated concrete could exacerbate other seismic PFMs such as gate and intake structure failure and internal erosion. As previously mentioned, there is no single generic failure or incident event tree associated with reinforced concrete deterioration; rather, the effects are typically reflected in the likelihood of events occurring for other PFMs or incident modes, such as the likelihood (probability) of open joints, offsets, surface tolerance, and/or cracks and spalls. Types of deterioration mechanisms that have been experienced are further discussed in the “Static (normal operations) PFMs,” specifically “Reinforced concrete structural failure.”

Appendix C

First Filing Guidelines

First Filling Guidelines

The following information was obtained from the June 1989 Assistant Commissioner - Engineering and Research (ACER) Memorandum No. DES-2, "Reservoir Filling Criteria Preparation." The memorandum was retired in 1994 when the Bureau of Reclamation's ACER was reorganized into the Technical Service Center (TSC). However, this document still provides excellent guidance for reservoir filling, and only minor rewriting has occurred to reflect updates to terminology, organizational references, and for clarity. Note that the following guidelines apply to both new dams and existing dams. Any time the historical maximum reservoir water surface (RWS) is exceeded, first filling guidelines apply. Also, because spillways and outlet works are instrumental in controlling reservoir filling, these guidelines are included in this design standard.

Reservoir filling guidelines will be established on a dam-by-dam basis. In general, the objective will be to provide a planned program with adequate time for monitoring and evaluating performance of the dam and its foundation as the reservoir is being filled for the first time.

Initial reservoir filling guidelines shall include the requirements for:

- 1. Surveillance and monitoring of the dam and its foundation.**
- 2. Controlling the rate of reservoir filling.**
- 3. Public safety contingency plans.**
- 4. Flood control during filling.**

Specific written reservoir filling guidelines will be prepared for each dam and reservoir. They will be furnished to operating personnel prior to initial filling (or exceeding historical maximum RWS). The Standing Operating Procedures (SOP) will also be prepared prior to initial filling (or exceeding historical maximum RWS) because it provides operating procedures to be followed during filling.

The reservoir filling guidelines will describe internal TSC procedures and responsibilities for receiving, reviewing, and evaluating the monitoring reports. The guidelines will also define periodic intervals at which the designer of record will provide interim reports to the TSC that evaluate the structural performance and reservoir conditions during reservoir filling.

Preparation of the initial reservoir filling (or exceeding historical maximum RWS) guidelines will be coordinated by the designer of record. The guidelines will be transmitted to the Regional Director with copies to the appropriate area office entities.

Design Standards No. 14: Appurtenant Structures for Dams (Spillways and Outlet Works) Design Standards

There may also be specific specifications requirements and initial readings and surveys that must be completed prior to initiation of first filling. The final foundation report must also be completed.

Surveillance and Monitoring

During first filling, special requirements on general surveillance, reading, and reporting of installed instrumentation are required, as well as normal and emergency operating procedures. In general, these requirements will address the following considerations:

- 1. Onsite attendance.**
- 2. Visual observations.**
- 3. Reading of instruments.**
- 4. Reporting of monitoring – visual observations and reading of instrument.**
- 5. Normal operating procedures.**
- 6. Emergency procedures.**
- 7. Procedures to be followed after earthquakes.**

The above considerations are developed on a dam-by-dam basis but usually require the following practices:

- 1. Onsite attendance.** – Onsite attendance depends upon site conditions and hazards to downstream development; however, it requires around the clock (24-hour) surveillance by trained observers, including operators and designers, at appropriate intervals.
- 2. Visual observations.** – Visual observations will include looking for cracks, seeps, slope instability, and other evidence of abnormal functioning. The dam, its abutments, and, as appropriate, the reservoir rim will be observed. Where the site and hazard conditions warrant, this will require floodlighting and 24-hour attendance by trained observers. It will be necessary to observe or monitor areas downstream from the dam.
- 3. Reading of instruments.** – Reading of instruments will be in accordance with special instruction and would normally be performed at frequent intervals but may be continuous and instantaneous reporting to the TSC's Instrumentation Group, designer of record, and other involved TSC entities. To carry this out effectively, the type of data to be transmitted, selection of appropriate instrumentation, and methods for data transmission will be determined during the design process.
- 4. Reporting of monitoring.** – Reporting of all monitoring will be at a frequency consistent with instrument reading, visual observations, and the nature of site conditions. The TSC Director and the Regional Director will

Chapter 4: General Outlet Works Design Considerations

be advised of monitoring results according to a schedule that takes into account site-specific conditions and structural performance, and they will be notified immediately of any abnormal conditions. The Division Chiefs of the Civil Engineering Services Division and the Geotechnical Engineering and Geology Division, and other appropriate group managers, as well as the designer of record, shall be on alert status during the first filling of reservoir space previously unfilled. The designer of record will be personally involved in directing normal operations of the dam. For reservoirs that require more than 2 years to fill active conservation and joint use space, special procedures will be established on a case-by-case basis.

If the initial filling will be to a low pool (less than half the dam's height), the initial reservoir filling plan may require nominal surveillance and monitoring. If the initial filling will be to a relatively high pool, however, the initial reservoir filling plan should also provide requirements for extensive surveillance and monitoring each time a higher storage pool is established during the operational life of a project.

Initial filling of the reservoir above the active pool may not take place for years. **It is especially important to require close monitoring of the initial filling at these critical elevations high in the reservoir.** For existing reservoirs that have not reached maximum (design) RWS, filling guidelines will be developed and placed in the SOP. An audit of these guidelines, where required, will be made during dam examinations.

5. **Normal operating procedures.** – Normal reservoir operations are those that carry out a predetermined operating plan as outlined in the written reservoir filling guidelines to maintain rates of filling and meet project requirements. This function will be performed by trained operators carrying out the plan in the written reservoir filling guidelines.
6. **Emergency procedures.** – Emergency reservoir operations take precedence over normal operations and, to the extent possible, will be carried out according to written contingency plans included in the reservoir filling guidelines. During emergency operations, the TSC Director and the Regional Director will provide direction.
7. **Procedures to be followed after earthquakes.** – Procedures to be followed after earthquakes will be, in general, those which have been established for existing structures. However, if there is a reason to believe that the reservoir size, depth, and geologic setting may induce seismic activity during filling, special inspection, monitoring, and reporting procedures may be necessary.

Filling Rates

Major factors to be considered in establishing the filling rate are as follows:

- 1. Purpose of the reservoir.**
- 2. Requirements for initiation of filling.**
- 3. Type of dam.**
- 4. Geology and seismicity of the dam foundation and reservoir.**
- 5. Hazard potential.**
- 6. Hydrology (inflow).**
- 7. Release provisions.**
- 8. Design considerations.**

The rate of filling must allow adequate time for monitoring and evaluation. The effects of each major factor will be evaluated on a dam-by-dam basis as discussed below:

- 1. Purpose of the reservoir.** – Most Reclamation dams are constructed primarily for the purpose of storing water for irrigation, generation of power, municipal and industrial uses, etc. Water in excess of downstream requirements would normally be stored unless other provisions preclude storage, as discussed later. If flood control is included in the reservoir operations, this can affect the filling and release rate.
- 2. Requirements for initiation of filling.** – Filling will normally begin at a low-flow period in a river to allow as much time as possible for monitoring and evaluation as the reservoir fills. However, water commitments and construction schedules may not permit this. The dam, spillway, and outlet works are normally required to be completed (and available) prior to initiation of filling.

When this is impractical, as in the case of an outlet tunnel used as a diversion tunnel, special precautions will be taken to ensure the safety of the dam while the outlet works are being completed. Prior to filling, all equipment required to operate the hydraulic structures will have been inspected to verify that they are functioning properly.

- 3. Type of dam.** – Concrete dams have a different behavior pattern than embankment dams during initial filling. Earth materials in the embankment dam and its foundation have properties that can exhibit significantly different behavior when they are saturated. Initial filling is generally synonymous with the beginning of saturation, which necessitates great caution and slower filling rates. Filling rates for concrete dams are normally less restricted than rates for embankment dams because the dam and its foundation are less susceptible to changed properties when they are saturated.

4. **Geology and seismicity of the dam foundation and reservoir.** – If the geology of the foundation or the reservoir indicates that rapid filling could cause problems, such as by altering the physical properties of the geologic materials, the filling rate will be restricted accordingly. Potential problems may include excessive seepage, landslides in the reservoir or in the abutments, and reservoir-induced seismicity.
5. **Hazard potential.** – The hazard potential to developments downstream from the dam will be assessed when determining the filling rate. Ample time must be provided to issue warnings (and for the public to heed them) in the event that problems develop.
6. **Hydrology (inflow).** – Inflows to the reservoir may be seasonal baseflows, controlled inflows, or floodflows. Seasonal baseflows will normally allow a slow filling of the reservoir. Controlled inflow from another reservoir will allow, within limits, the establishment of ideal rates of filling. Floodflows are unpredictable, and their effect on the filling rate must be evaluated. This evaluation is made by routing various flows into the reservoir, assuming that the reservoir is at some initial level. Historically, these inflows may include flows of record or 5-, 10-, and 25-year frequency floods. Releases may be restricted to project requirements for safe channel capacities, but they should not increase the potential for dam failure due to rapid filling or overtopping. The results of these routings are then evaluated in rapid filling in terms of other factors, including: type of dam, geology, downstream hazard, etc. Consideration will also be given to floods or larger recurrence intervals. In these cases, faster filling rates are usually considered acceptable. However, it may be necessary to lower the reservoir after these events, or at least place a hold on the RWS for some period of time. As an example, during the 1993 first filling of New Waddell Dam, a flood event resulted in rapid filling of a portion of the reservoir, and the filling guidelines were exceeded. This was rectified by releasing large discharges and implementing an extended hold period to monitor the dam after the flood event.
7. **Release provisions.** – The outlet works is normally sized so that the release capacity meets downstream water requirements and evacuation requirements. This discharge capacity is normally sufficient to limit the filling rate. However, if additional discharge capacity is needed to limit the filling rate, it will be considered during the design process and, if feasible/viable, incorporated into the design.

Filling rates are not normally specified for the lower half of the depth of the reservoir because the dam will receive only a fraction of its normal load. Filling will naturally occur more rapidly in the lower portion of the

**Design Standards No. 14: Appurtenant Structures for Dams
(Spillways and Outlet Works) Design Standards**

reservoir due to the smaller storage to elevation relationship. However, if there are areas of concern in the lower portion, appropriate filling rates will be specified.

In the upper portion of the reservoir, filling rates may vary from less than 1 foot to several feet per day, allowing ample time for monitoring and evaluation. Up to 1 foot per day would be considered a normal filling rate for most embankment dams, while 10 feet per day may be acceptable for a concrete dam on a competent rock foundation. Outlet works will have sufficient release capacity to limit the reservoir rise to the specified level. The filling rate established will allow time for the dam and abutments to respond to the increased water load and to determine that the phreatic water surface in the dam and foundation is developing normally.

In some cases, it is preferable, from an initial performance standpoint, to control the filling in stages to allow the dam to respond to a particular level of filling and the designer of record (and others) to evaluate the data more carefully before proceeding to the next level.

- 8. Design considerations.** – Adequate time will be provided to evaluate responses to loading at different reservoir elevations, for location and response time of instrumentation, and for design or topographic conditions that may affect anticipated performance. In addition, conditions encountered during construction or major design modifications may be considered in the development of filling guidelines.

Public Safety Contingency Plans

Public safety contingency plans, such as Emergency Action Plans, should be prepared by the region, incorporated into the SOP, and be in the hands of operating personnel prior to the start of initial filling of the reservoir. TSC personnel should assist the region in preparing the contingency plans. Potential hazard areas will be identified. Plans will include courses of action and identify who is responsible for initiating the action for potential problems that might be encountered.

Contingency plans will be in effect during emergency situations and will include alerting public officials, law enforcement agencies, and the communications media. The Regional Director will be responsible for the direction of Reclamation's emergency public safety activities involving safety of the public downstream from the dam.